

BID SUBMITTAL FORM
Alabama County Joint Bid Program
BID ITEM – 16' STEEL DUMP BODY – OPTION B (AUTOMATIC TRANSMISSION)

Company Name: Logan Corporation / Dump Bodies

Address: 124 Ward Road

Salyersville, Ky 41465

Bid Submitted by: Michael Conada

(Name of company representative)

Title: Customer Representative E-mail address: Mike.Conada@logancorp.com

Phone: 606-791-7208 Fax: 606-349-1144

By submitting this bid, we agree:

Initials

That the equipment model number identified below meets the bid specs for this bid item

MC

That the bid price will be honored for all counties for the period from January 1, 2023 to December 31, 2023.

MC

That the equipment will be delivered at the bid price to all counties participating in the joint bid program

MC

That the company representative listed above will be the contact person for purchasing this bid item under the joint bid program

MC

That the bid is accompanied by a current catalog or model specification document for the model number identified below

MC

That the bid is accompanied by a copy of the manufacturer's standard warranty as required in the bid specifications

MC

That the bid includes the e-verify documentation required by Alabama law

MC

That, if awarded the bid, a performance bond will be provided upon request

MC

That an option sheet with individual pricing is attached

MC

Total Bid Price including options: \$ 41,110.00

Equipment Model #: LE

Description: Logan Cross-Memberless Body

Signature of company representative submitting bid: Michael Conada

Title: Customer Representative

OPTION COST SHEET FOR 16' STEEL DUMP BODY – OPTION B (AUTOMATIC TRANSMISSION)

<u>Tri Axle Option Items</u>	<u>Option Price</u>
Silent Drive or equal lift axle	\$ <u>5,500.00</u>
Four Steel Disc, Ten hole, hub piloted, bud style 22.5x8.25 wheels on lift axle	\$ <u>575.00</u>
Four 11R22.5 recap tires on lift axle	\$ <u>1,400.00</u>

<u>Other Options</u>	<u>Option Price</u>
High lift tail gate	\$ <u>750.00</u>
Bed body vibrator	\$ <u>700.00</u>
25 ton heavy duty Pintle Hitch	\$ <u>1,250.00</u>
Chip Spreader bar mounted	\$ <u>400.00</u>

NOTE: Award will be made on the basis of the total cost of the machine with all options included. However, a county may, at its discretion, deduct one or more of the above-referenced options from the machine, and in such event, the cost of the option as stated on the bid shall be deducted from the total cost of the machine. There shall be no other deductions and no additions made to the machine by the purchasing county or by the vendor.

Equipment Model #: HE Body

Description: Logon Cross-Memberless Body

Signature of company representative submitting bid: Michael Conrad

Title: Customer Representative

BID SPECIFICATIONS FOR 16' STEEL DUMP BODY OPTION B (AUTOMATIC TRANSMISSION)

GENERAL

These specifications shall be construed as the minimum acceptable standards for a 16' Steel Dump Body. Should the manufacturer's current published data or specifications exceed these standards, the manufacturer's standards shall be considered minimum and shall be furnished. All integral parts not specifically mentioned in the scope of these specifications that are necessary to provide a complete working unit shall be furnished. Additionally, the machine offered for bid shall include all standard manufacturer's equipment. The 16' Steel Dump Body must be a new current production model.

The use of specific names or numbers in the specifications is not intended to restrict the bidder or any seller or manufacturer, but is intended solely for the purpose of indicating the type, size, and quality of equipment considered best adapted to the uses of counties participating in this joint bid.

BID SUBMITTAL FORM

Each bidder must submit his or her bid on the Bid Submittal Form included in the invitation to bid package. All written warranties to be submitted shall be attached to the Bid Submittal Form.

BID PRICE

The price bid shall include all destination charges, delivery charges, title fees, rebates and all other applicable costs and refunds.

REPLACEMENT PARTS AVAILABILITY

Parts must be available for 5 years or 500,000 miles of use for the piece of equipment bid.

ASSEMBLY AND DELIVERY

The dump body will be purchased for use with a heavy duty dump truck chassis (with Automatic Transmission) bid separately. The dump body company will be responsible for assembly and installation of the dump body and related optional equipment, including the cost of the same. The selling truck chassis dealer will be responsible for delivery of the chassis to the dump body company, for installation and for delivery of the complete dump truck unit to the county following installation, and assembly of the dump body and related options onto the truck chassis. Freight to and from the dump body company will be included in the truck bidder's proposal. Dump body installation and assembly costs will be included in the dump body bidder's proposal.

WARRANTY

Bidders shall submit a copy of the manufacturer's standard warranty.

Yes No

Page# 8

or

Attachment

DUMP BODY

Dump body shall meet all federal and state, health and safety regulations and must conform to American National Standard Institute (A.N.S.I.) Regulations (A.N.S.I.Z145) 1975.

Yes No

Page # _____

Dump body supplier must have their own service and parts facility.

Yes No
Page # _____

Dump body supplier must have a minimum of five (5) years' experience in sales, service and repair of dump bodies.

Yes No
Page # _____

Body must be covered by product liability insurance.

Yes No
Page # 9-10

GENERAL SPECIFICATIONS AND DIMENSIONS

21 cubic yard capacity; elliptical dump body design with 26 inch radius beginning at body main rails; 16 feet long; 62-inch high sides; 64- inch high tailgate; sides, floor and tail-gate shall be 1/4 inch AR450 Steel; tailgate shall be vertical (NO SLOPE); three (3) panel tailgate design; hoist shall be class 120 hoist with a minimum four (4) active stages and minimum 60,000 pound capacity; direct mount integral pump and P.T.O. combination with air control on the P.T.O.; air tailgate latch control; tailgate Shall be built for future high lift tailgate conversion; tarp with vinyl asphalt type tarp; 42 inch cab shield; eight (8) inch wide schedule 80-pipe push bar asphalt apron across rear of body; 3.5 inch inverted angle on top of sides and top of tailgate; and Metro light kit.

Yes No
Page # 6-7

TRI AXLE OR HEAVY DUTY DUMP TRUCK CHASSIS OPTIONS

The chassis (with Automatic Transmission) will be used as a tri axle dump or a heavy duty tandem dump. All bids shall include the cost for each of the following options to be selected for a tri axle dump, itemized separately on the bid:

Silent Drive Lift (Pusher) axle (20,000 lb. minimum Capacity) or equal. This axle shall be air up and air down with a control valve and regulator located in the cab within reach of the operator.

Yes No
Page # 6-7

Four (4) steel disc, ten (10) hole, hub piloted, bud style 22.5x8.25, wheels on lift axle.

Yes No
Page # 6-7

Four 11R22.5 recap tires on lift axle.

Yes No
Page # 6-7

OTHER OPTIONS

Bid must include the cost for each of the following options, itemized separately on the bid:

High lift tail gate

Yes No
Page # _____

Bed body vibrator

Yes No
Page # 2

25 ton heavy duty Pintle Hitch, swivel type, spring loaded, with safety chain rings, six (6) prong trailer light socket and air brakes hookup. Mounted 26 inches from ground with truck empty.

Yes No
Page # 6-7

Chip spreader bar mounted at end of frame.

Yes No
Page # 6-7

NOTE: Award will be made on the basis of the total cost of the dump body with all options included. However, a county may, at its discretion, deduct one or more of the above-referenced options from the dump body, and in such event, the cost of the options as stated on the bid shall be deducted from the total cost of the dump body. There shall be no other deductions and no additions made to the dump body by the purchasing county or by the vendor.

✓



www.logandumpbodies.com

124 Ward Road
Salyersville, KY 41465
Phone: (606)349-1744
Fax: (606)349-1144

Quote Date: 9/20/2022

Prepared by: Mike Canada

Quote #: 22-092091657

Reference: ACCA ALABAMA LE BODY AUTOMATI

CUSTOMER: 300052
PRE-ACCOUNT CUSTOMER

SHIP TO:
PRE-ACCOUNT CUSTOMER

ATTN: Patrick McDougald 334-263-7594 barbeng@bellsouth.net

Chassis Info:

OEM: NEED NEED C/A-C/T: NEED
VIN: NEED Pivot: NEED
Cab to Body: NEED Overhang: NEED
Transmission: AUTOMATIC TRANSMISSI Cab Height: NEED

Body:

Model: LE
Installation: Installed
Length: 16'
Inside Width/Outside Width: 86" Inside 96" Outside

Understructure:

Deck: 1/4" AR 450
Longsills: FORMED W/2" RUBBER

X-Members: NONE, FULLY X-MEMBERLESS
X-Member Spacing: NONE, FULLY X-MEMBERLESS

Sides:

Side Height: 62"
Side Material: 1/4" AR 450
Bottom Rail / Fender: 10GA HIGH TENSILE
Side Boards: 2 X 2 X 1/4" INVERTED ANGLE
Aluminum Fender Covers: NOT INCLUDED

Top Rail: FORMED SELF-SHEDDING
Vertical Side Bracing: NOT INCLUDED
Horizontal Side Bracing: NOT INCLUDED
Boarding Ladder: TREAD GRIP STEPS W/INTEGRATED HAND GRIPS

Bulkhead:

Bulkhead Height: NEED
Bulkhead Material: 1/4" AR 450
Shovel Holder: NOT INCLUDED
Inside Steps: DRIVER'S SIDE, INTEGRAL ANTI-SLIP DESIGN

Cabshield: FULL WIDTH, W/FORMED IN WIND DEFLECTOR, 10GA
Cabshield Length: 36" Width:
Cabshield Material: 10GA HIGH TENSILE

Tailgate:

Tailgate Height: 66"
Tailgate Material: 1/4" AR 450
Top Hinge Style: HD HIGH LIFT, W/CYLINDERS IN POSTS
Tailgate Safety Chains: 3/8" HIGH GRADE, W/PROTECTIVE SLEEVE
Stoker Door: NOT INCLUDED
Apron: 8" HEAVY DUTY PIPE BUMPER

Tailgate Slope: NO SLOPE
Panels: 3
Bottom Latch Style: OVERSLUNG, PLATE STEEL W/BRASS BUSHINGS
Bottom Latch Controls: ALUMINUM AIR CYLINDER OPERATED
Wing Latches: NOT INCLUDED
Tailgate Options: * TREAD PLATE PROTECTIVE COVER AT SAFETY CHAIN AREA * INVERTED ANGLE ON TOP OF GATE

le

Lights: All Lights are LED by: 

Bottom Side Markers: 2
Rear Stop/Tail/Turn: 1
Front Strobes: 2

Top Side Markers: 0
Cabshield Markers: 2
Rear Strobes: 2
Light Options:

Hydraulics: Logan's standard hoists by: 

Hoist Model: CUSTOM HOISTS 63-140
Pump: DIRECT MOUNT 2" GEAR
Pump Controls: AIR FEATHERING
Pump Cutoff: AIR

PTO: PARKER CHELSEA HOT SHIFT FOR AUTO TRANSMISSION
PTO Controls: WIRED TO SWITCH IN DASH
Console: ALUMINUM, WITH INSPECTION COVER
Hydraulic Tank: STEEL FRONT MOUNT, 25GAL

Paint: All bodies coated with 

Body Primer: AXALTA TUF-COTE, HIGH SOLIDS ALKYD PRIMER
Body Topcoat: AXALTA IMRON ELITE, POLYURETHANE ENAMEL

Top Coat Paint Code: NEED
Side Boards: NOT INCLUDED

Chassis Components:

Rear Hinge: 1 3/4" PIN STRAP STYLE, WITH FULL PIN
Body Safety Prop: INTEGRATED WITH REAR HINGE
Subframe: FORMED 36" Z BAR, INCLUDED INTEGRAL RETAINER PLATES
Backup Alarm: INCLUDED

Rear Frame Bumper: 3" ROUND BUMPER, REUSE FACTORY LIGHTS
Front Flaps: STEEL MUD GUARDS
Rear Mud Flaps: STANDARD HD LOGAN RUBBER FLAPS

Tarp:

Type: MOUNTAIN ELECTRIC FLIP TARP SYSTEM
Wind Deflector: FORMED IN CAB SHIELD

Material: ASPHALT VINYL
Tarp Options:

Options Included:

	Qty
1: OP 20K NON STEER AXLE	1
2: OP AIR VIBRATOR INST	1
3: OP 3/4" PINTLE PLATE INST	1
4: OP PH760 PINTLE HOOK INST	1
5: OP 8.25X22.5 STEEL RIM	4

	Qty
6: OP 11R22.5 TIRE INST	4
7:	
8:	
9:	
10:	

Special Options:

>>>CABSHIELD LENGTH TO BE 42" <<<

>>>APPROXIMATE YARDAGE TO BE 21 YD <<<



DUMP BODY PRODUCT LINE LIMITED WARRANTY AND DISCLAIMER

Logan Corporation provides a twelve-month Limited Warranty (beginning on the delivery date of the equipment) to the original retail purchaser of its dump body line of products. This Limited Warranty covers the original equipment provided by Logan to be free of defects in material and/or workmanship during the warranty period. Damaged or defective parts that were created due to conditions outside of the normal use intended for the product are expressly not covered. Component parts that are not manufactured by Logan will have their warranty limited to the warranty limitations of the respective component providers.

Products covered under this Limited Warranty will be replaced or repaired in Logan Corporation's sole discretion, with all such warranty work to be done at Logan's Salyersville, Kentucky, facility or such other location or facility chosen by Logan Corporation in its sole discretion. Any attempts to repair or replace allegedly defective parts or components of products subject to this Limited Warranty without first obtaining written authorization from Logan Corporation will automatically void this Limited Warranty and Logan Corporation expressly disclaims all liability to purchaser. Logan reserves the exclusive right to specify any repair methods and/or component replacement repairs as it deems necessary in its sole discretion. Any unauthorized repairs to products subject to this warranty shall automatically void this Limited Warranty.

This Limited Warranty does not obligate Logan Corporation to assume liability for the loss of time, or product, or any consequential damages or losses arising directly or indirectly from defects in material and/or workmanship in the products subject to this Limited Warranty, and Logan Corporation expressly disclaims the same.

Additional limitation to this Limited Warranty:

- Logan Corporation will reimburse a maximum of ninety dollars (\$90) per hour for labor for repairs approved by Logan Corporation.
- All power take-off units, hydraulic pumps, hoses, and associated fittings will be warranted for a period of thirty (30) days from original delivery date only. This additional limitation is due to the fact that regular maintenance is necessary to maintain and prevent leaks or fasteners loosening due to vibration and normal use.
- Any equipment that has been added, altered, or removed in any way so as to affect the safety or operational function(s) of the OEM Logan product is expressly exempt from this Limited Warranty.
- Normal maintenance or service is expressly not covered by this Limited Warranty.

Failure to acknowledge receipt and register this warranty shall in no way affect the limitations of warranty outlined herein.

To register the warranty on a new Logan Corporation dump body, go to:
www.logandumpbodies.com.



General Liability coverage premium summary

Policy Number 630-3T86029A

Coverage information

COVERAGE		LIMITS
Aggregate Limits of Insurance	General Aggregate (Other than Products-Completed Operations)	\$2,000,000
	Products-Completed Operations Aggregate	\$2,000,000
Personal And Advertising Injury Limit (Subject to the General Aggregate Limit)	Any One Person or Organization	\$1,000,000
	Combined Single Limit Bodily Injury & Property Damage (Subject to the General Aggregate Limit or the Products-Completed Operations Aggregate Limit)	\$1,000,000
Each Occurrence Limit		
Damage To Premises Rented To You Limit (Subject to Each Occurrence Limit)	Any One Premises	\$300,000
Medical Expense Limit (Subject to the Each Occurrence Limit)	Any One Person	\$5,000

Composite General Liability class code schedule

CLASS CODE	DESCRIPTION	SUBLINE	EXPOSURE	RATE	PREMIUM
33000	MANUFACTURERS - METAL PRODUCTS (TRAVELERS)	Combined	20,000,000	2.424	\$48,480

Non-composite General Liability class code schedule

STATE	LOC/BLDG	CLASS CODE	DESCRIPTION	SUBLINE	EXPOSURE	RATE	PREMIUM
WV	1/1	61224	BUILDINGS OR PREMISES - OFFICE - PREMISES OCCUPIED BY EMPLOYEES OF THE INSURED - OTHER THAN NOT-FOR-	Prem/Ops.	2,000	55.373	\$111

Optional coverage

9

COVERAGE
XTEND-PO

LIMIT

PREMIUM
Included

Gross Premium	\$50,632
Taxes and Surcharges	\$5,591
Total	\$56,223

Employee Benefits Liability(Claims Made Coverage) Premium	\$300
Aggregate Limit	\$2,000,000
Each Employee Limit	\$1,000,000
Deductible	NONE
Retroactive date	6/30/2022



General Liability coverage premium summary

CG D4 58 – XTEND Endorsement For Manufacturers And Wholesalers

COVERAGE

Who Is An Insured	Unnamed Subsidiaries
Who Is An Insured	Employees And Volunteer Workers – Bodily Injury To Co-Employees And Co-Volunteer Workers
Who Is An Insured	Newly Acquired Or Formed Limited Liability Companies
Blanket Additional Insured	Broad Form Vendors
Blanket Additional Insured	Controlling Interest
Blanket Additional Insured	Mortgagees, Assignees, Successors Or Receivers
Blanket Additional Insured	Governmental Entities – Permits Or Authorizations Relating To Premises
Blanket Additional Insured	Governmental Entities – Permits Or Authorizations Relating To Operations
Blanket Additional Insured	Grantors Of Franchises
Incidental Medical Malpractice	
Medical Payments	Increased Limit
Blanket Wavier Of Subrogation	
Contractual Liability	Railroads

Company ID Number: 1898520

Approved by:

Employer LOGAN CORPORATION	
Name (Please Type or Print) Kyle Cox	Title
Signature Electronically Signed	Date 10/04/2022
Department of Homeland Security – Verification Division	
Name (Please Type or Print) USCIS Verification Division	Title
Signature Electronically Signed	Date 10/04/2022

Company ID Number: 1898520

Information Required for the E-Verify Program

Information relating to your Company:

Company Name	LOGAN CORPORATION
Company Facility Address	1126 20TH STREET huntington, WV 25703
Company Alternate Address	
County or Parish	CABELL
Employer Identification Number	550219530
North American Industry Classification Systems Code	423
Parent Company	
Number of Employees	20 to 99
Number of Sites Verified for	2 site(s)

Company ID Number: 1898520

Are you verifying for more than 1 site? If yes, please provide the number of sites verified for in each State:

KY	1
WV	1

Company ID Number: 1898520

Information relating to the Program Administrator(s) for your Company on policy questions or operational problems:

Name Kvie Cox
Phone Number 3852828796
Fax
Email kvie.cox@locancorp.com

RCA-215 - Truck

Auxiliary Axle Suspension – NonSteerable

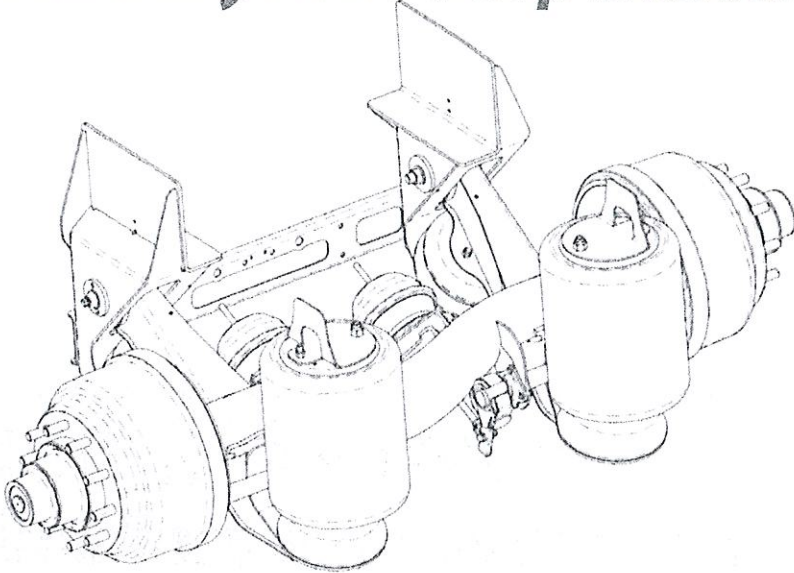

Installation and Service Manual

Suspension Identification -----2

Installation

Prior to Installation -----3

Axle Integration -----4

Suspension Mounting -----6

Air Control Kit (ACK) Components - Lifiable Axle -----8

Maintenance

Recommended Service Intervals -----9

215 Truck – Drum Brakes -----10

215 Truck – Disc Brakes -----10

Air Spring Mounting Plate/Spacer Index -----11

Bushing Replacement/Torque Specifications -----12

Axle Alignment -----15

Warranty ----- 16



SUSPENSION IDENTIFICATION

Introduction

The Ridewell Compact Air Ride (RCA) 215 Truck Suspension can be purchased with or without an integrated axle for use in a wide range of applications.

Refer to the engineering drawing for detailed information on the suspension system components and operating parameters.

Suspension Identification Tag

A (606-) **Installation/Assembly Number** will be listed as the **Part Number** when other system components are factory installed with the suspension (Figure 1).

The **Suspension Number** and **Serial Number** on the Suspension ID Tag refer to the model and the date of manufacture of an individual suspension system.

Please refer to the suspension number/part number and serial number on the Suspension Identification Tag when contacting Ridewell for customer service, replacement parts and warranty information.

Axle-Body Identification Tag

The **Base-Axle Part Number (165-)** and the **Serial Number** of the axle tube are listed on the Axle-Body ID Tag of Ridewell-branded round axles (Figure 2).

The **Base-Axle Part Number** refers to Ridewell-branded round axles manufactured with assorted wall thicknesses and widths.

More information on Ridewell-branded axles can be found in the "Trailer Axle Parts Guide" (P/N 9710029).

Notes and Cautions

All work should be completed by a properly trained technician using the proper/special tools and safe work procedures.

Read through the entire Installation and Service Manual (ISM) before performing any procedures.

The ISM uses two service notes to provide important safety guidelines for the suspension operation.

The service notes are defined as:

"NOTE": Provides additional instructions or procedures to complete tasks and make sure that the suspension functions properly.

CAUTION Indicates a hazardous situation or unsafe practice that, if not avoided, could result in equipment damage and serious injury.

 RIDEWELL SUSPENSIONS The Engineered Suspension Company	
PART NO:	
SUSP. NO:	
SERIAL NO:	
GROSS AXLE WEIGHT RATING CERTIFICATION IS PER THE FINAL STAGE MANUFACTURER OR ALTERER.	
THIS PRODUCT MAY BE COVERED UNDER ONE OR MORE PATENTS, ADDITIONAL PATENTS MAY BE PENDING.	
www.ridewellcorp.com	(800) 641-4122

Figure 1.
The Suspension Model (Suspension Number) and date of manufacture (Serial Number) are listed on the Suspension Identification Tag.

 RIDEWELL SUSPENSIONS			
MODEL:		PART NO.	
SERIAL NO.		CAPACITY	TON

Figure 2.
The Base-Axle Part Number (165-) and the Serial Number assigned to the axle tube are listed on the Axle-Body Serial Identification Tag.

Prior to Installation

Refer to the engineering drawing to confirm dimensional requirements and the range of ride heights available. Operating the suspension outside of design parameters can result in improper performance, damaged equipment, and void the warranty.

The methods and procedures listed in this manual are considered to be general practices. Installations can vary and procedures should be adapted for different vehicles, as needed.

- The Gross Axle Weight Rating (GAWR) is determined by the system component with the lowest load rating. Please consult with tire, wheel, axle and brake manufacturers before installation to determine the GAWR.
- If vehicle chassis modifications are required, consult with the vehicle manufacturer to ensure that such changes are permitted.
- Welding or altering suspension components is not permitted without the express written permission of Ridewell Suspensions.

Installer Responsibilities

The installer of the suspension has the sole responsibility for proper attachment of the suspension system to the vehicle chassis.

- The installer is responsible for locating the suspension system on the vehicle to provide the proper load distribution.
- The installer must verify that vehicle crossmembers are positioned to support the suspension at the installing location.
- It is the installer's responsibility to determine that axle spacing conforms to any applicable federal and local bridge laws.
- The installer must verify that air reservoir volume requirements are met after suspension installation. Consult the vehicle manufacturer or Federal Motor Vehicle Safety Standards (FMVSS) 121 for more information.
- The installer must verify there is sufficient clearance for proper functioning of the auxiliary suspension, air springs, brake chambers, steering components, axle (including axle to driveline clearance) and tires.

Axle Integration

Suspension systems are available with and without a factory integrated axle. Customer-supplied axle assemblies must be positioned and oriented (rotated) properly before welding the axle.

Use the top-center mark on the axle, if available, to identify the center of the axle and orient the axle assembly on the suspension. The axle assembly should be installed so that the camshafts, when activated, rotate in the same direction as the wheels.

CAUTION Failure to follow procedures and design specifications could result in injury, damage to the axle or suspension and void the warranty.

Weld Preparation

The joint to be welded should be positioned in the flat or horizontal position. All grease, dirt, paint, slag or other contaminants must be removed from the weld joint.

The axle and suspension components should be at a minimum temperature of 60°F (15.5°C). Pre-heat the weld zone to the axle manufacturer's recommended pre-heat temperature, if required.

Weld Procedure

1. Center the axle assembly on the beams (Figure 3).
2. Check the engineering drawing for the brake component orientation (rotation) before clamping into place and making the final welds.
 - 2.1. Drum brake camshafts are spaced off the tail of the trailing arm beam. Make sure the brake chamber brackets are oriented properly and clamp the axle assembly into place.
 - 2.2. Disc brake assemblies have a right- and left-hand caliper assembly. Make sure the callipers are located on the correct side and rotated to the proper position before clamping the axle assembly into place.
3. Check the gap between the axle and the axle seats before welding (Figure 4). Side gaps should be no greater than 1/8". The gap at the bottom of the axle seat should be no greater than 1/16".
4. Weld the axle to the seat according to Ridewell Weld Process #1 (Page 5).

NOTE: Mounted air springs should be covered to protect them from welding spatter.

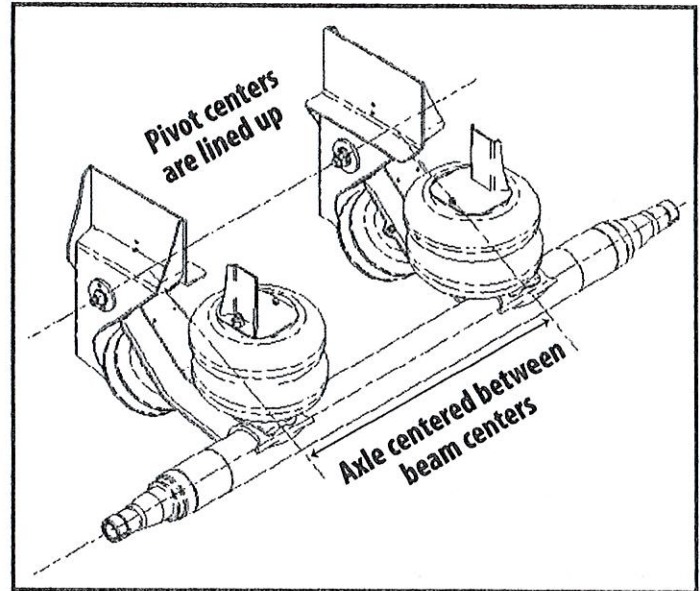

Figure 3.
Axle should be centered between beams.

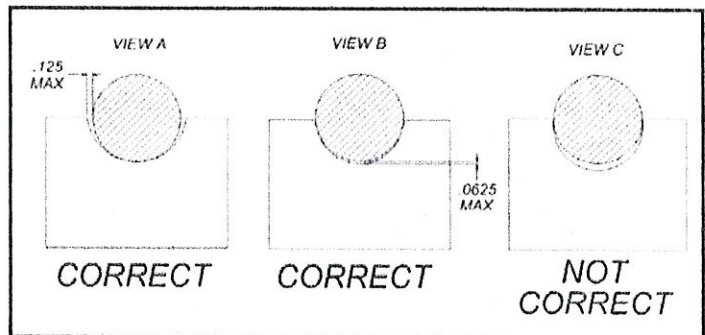
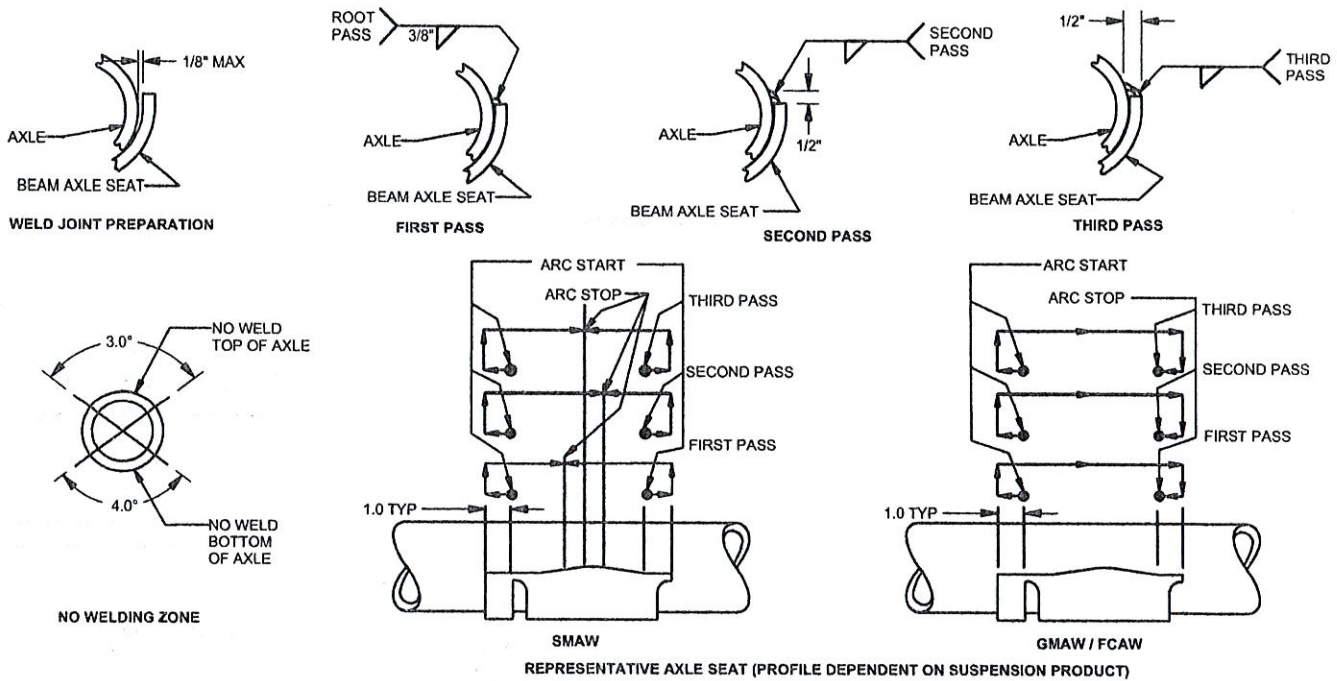
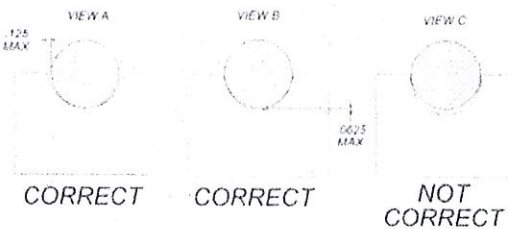

Figure 4.
Positioning axle for welding to axle seat.



- 1 - CAUTION: All welds must be kept away from the top and bottom of the axle where maximum stresses occur (see "NO WELDING ZONE" illustration above). Do not test-weld the arc on any part of the axle tube.
- 2 - All welders and welding operators should be certified as per the requirements of the American Welding Society (AWS) or equivalent. All electrodes used should meet the AWS specifications and classifications for welding carbon and low-alloy steels.
- 3 - Recommended Welding Methods: Shielded Metal Arc Welding (SMAW), Gas Metal Arc Welding (GMAW) or Flux Cored Arc Welding (FCAW). The welding method used and the electrode selected must develop a minimum weld tensile strength of 70,000 psi per AWS specifications. The best fusion and mechanical properties will be obtained by using the voltage, current, and shielding medium recommended by the electrode manufacturer. If the SMAW method is used, the stick electrodes must be new, dry, free of contaminants and stored per AWS specifications.
- 4 - Weld Joint Preparation: The joint to be welded should be positioned in the flat or horizontal position. All grease, dirt, paint, slag or other contaminants must be removed from the weld joint without gouging the axle tube. CAUTION: Never weld when the axle is cold. The axle and beam assemblies to be welded should be at a temperature of at least 60°F (15°C). Pre-heat the weld zone to the axle manufacturer's recommended pre-heat temperature, if required. This will reduce the chance of an area of brittle material forming adjacent to the weld.
- 5 - The axle should fit into the beam assembly with a maximum root gap of 1/8-inch between the axle and the beam axle seat (see "WELD JOINT PREPARATION" illustration above).
- 6 - NOTE: Clamp the axle to the beam axle seat with a C-clamp prior to welding to make sure that proper contact occurs (see "CORRECT" illustration below).
- 7 - Ground the axle to one of the attached axle parts such as the brake chamber brackets, cam brackets or brake spider. Never ground the axle to a wheel or a hub as the spindle bearing may sustain damage.
- 8 - Multiple pass welding should be used on the beam/axle connection using the following guidelines: 8.1-Total fillet weld size should be 1/2-inch. 8.2-Weld pass starts and stops should be performed as illustrated above. 8.3-Never start or stop welds at the end of the weld joint. 8.4-Each pass must be accomplished in one or two segments. 8.5-Start welds at least 1-inch from the end and backweld over the start. Backstep fill all craters. 8.6-If process is not GMAW all slag must be removed between passes. 8.7-Welds must go to within 1/8-inch +/- 1/16-inch of the ends of the axle seat and must not go beyond or around the ends of the axle seat. 8.8-Post-weld peening is recommended, but not required: Needle peen the entire toe of the second pass, including around the ends of the axle seat. Hold the needles perpendicular to the axle. A uniform dimpled pattern will appear when properly peened.



F	16101	ADDED MAXIMUM TO 5, ADDED GMAW NOTE TO 8.6 UPDATED CORRECT VIEWS	2/10/2016	G.H.	B.B.	CJB
E	15101	REVISED TEXT. REMOVED LIST OF MODELS.	6/30/15	G.H.	MDJ	CJB
REV	PROJECT	DESCRIPTION	DATE	BY	CHK	APPD
DRAWN BY:	CBC	2/1/2016	RIDEWELL CORPORATION PO BOX 4586 SPRINGFIELD, MISSOURI 65808			
CHECKED:	MDJ	2/21/2003				
APPROVED:	CJB	2/21/2003				
PROJECT NO:	03103	SCALE: A-SIZE: NTS	TITLE: RIDEWELL WELD PROCESS #1, 5" DIA. AXLE, 3 PASS WELD			
MATERIAL:	-	WEIGHT: -	SHEET 1 OF 1		PART NO. WELD PROCESS #1	REV: F

Suspension Mounting

Refer to the engineering drawing for the suspension travel table; mandatory customer-supplied cross-member locations; the recommended bolt-hole locations for suspension mounting; and, the suspension spacing and clearance requirements.

An optional shock absorber kit for RCA 215 Low-Mount and Mid-Mount Suspensions can be installed after the suspension is mounted.

Bolt-On Installation Procedure

Grade-8 bolts, flanged locknuts or locknuts with hardened washers for suspension mounting are supplied by the installer.

The hanger crosschannel should be installed after axle integration. Torque locknuts to 45-50 ft-lb.

Suspension heights can be adjusted with a 1" or 2" air spring/hanger mounting spacer kit (Page 11).

1. Locate the hangers and air spring mounting plates/spacers on the chassis and clamp firmly into place.
2. Check that hangers/mounting plates/spacers are evenly located and square to the frame. Verify that location provides adequate clearance for the assembled suspension components.
3. Center-punch and drill eight bolt-holes (min 5/8") in each frame hanger. Center-punch and drill two bolt-holes (minimum 5/8") in each air spring mounting plate.

CAUTION Corresponding hanger mounting spacer must be installed with the air spring spacer. All Hangers/Mounting Plates/Spacers must have full contact with the bottom of the vehicle frame.

NOTE: Space the bolt-holes for mounting as far apart as possible if the recommended bolt-hole locations are not available.

CAUTION Check to make sure that wires, hoses or other components located within the chassis are not affected by drilling the bolt-holes.

4. Bolt suspension assembly to vehicle chassis with 5/8" Grade 8 bolts and locknuts.
5. Attach the load springs to the air spring mounting plates. Torque to specifications (Page 12).
6. Install/connect the air control kit (ACK). Check the air system after installation for leaks (Page 8).
7. Perform final assembly and inspection and align the suspension per TMC or SAE recommended standards. Alignment should be performed with suspension at installed ride height (Page 15).

Final Assembly and Inspection

1. Verify that all suspension components are torqued to specifications (Page 12).
2. Install wheels and tires.
CAUTION When lowering an auxiliary axle on an unloaded vehicle, pressure to the load air springs must be reduced to below 10 psi. Failure to reduce the air pressure could cause the vehicle's drive axles to rise from the ground and the vehicle could roll in an unsafe manner.
3. Check that tires are inflated to recommended pressure. Check wheel hubs for proper level of lubricant recommended by the manufacturer.
4. Lift the axle to the raised position. Check the air system tubing and connections for leaks.
5. Check that wheels can rotate freely and that brakes are properly adjusted.
6. Raise and lower the suspension assembly through the entire range of travel. Check for sufficient vehicle clearances of air springs, brake chambers and other components.

CAUTION Do not lower the auxiliary axle while the vehicle is moving above 10 mph.

Optional- Shock Absorber Installation

Refer to the shock absorber kit engineering drawing for the mounting locations and the upper and lower mounting bracket installation angles.

CAUTION The welding method for the lower mounting bracket must use a minimum weld tensile strength of 70,000 psi, per AWS specifications.

1. Disconnect and remove the load springs from the suspension assembly. Protect the lift springs from welding spatter.
2. Locate and drill three holes in the chassis above the air spring mounting plate for the upper mounting bracket. Bolt the bracket to the chassis with customer-supplied Grade 8 bolts and locknuts (5/8" recommended).
NOTE: Adjust the upper brackets' installation height if hanger and air spring spacers are installed. Rotate the brackets to allow shock absorbers to clear the air spring mounting plates.

continued on next page

Shock Absorber Installation (continued)

3. Measure the location of the shock absorber to axle (lower) mounting bracket from the edge of the axle seat, not from the axle weld. Clamp the bracket into place.
Use a 5/16" fillet weld to weld the lower mounting bracket to the axle at the forward and rear edge only. Do not weld perpendicular to the axle centerline.
4. Attach the shock absorber to mounting brackets.
 - 4.1. Attach the shock to the upper mounting bracket with the supplied Hex Head Cap Screw (HHCS) and flat washer. Torque HHCS to 160-200 ft-lb (217-271 N-m).
 - 4.2. Attach shock to the lower mounting bracket with supplied HHCS and locknut. Torque locknut to 160-200 ft-lb (217-271 N-m).
5. Install load springs. Torque to specifications (Page 12). Connect load springs to air system.
6. Raise and lower the suspension to make sure that shock absorbers clear the air spring mounting plates and do not overextend during travel.

CAUTION Failure to torque suspension components to specifications can result in failure of the suspension and void the warranty.

Regulate load with air spring pressure

The load capacity of the auxiliary axle is adjusted by increasing or decreasing the pressure to the air springs. By applying more air, the lift axle takes on a greater percentage of the load's weight. The load capacity is decreased as the air pressure decreases.

Accurate readings of the load capacity can be obtained by parking a loaded vehicle over a calibrated scale and lowering the axle onto the scale. The air pressure to the air springs is manually adjusted up or down to obtain the axle load weight at various air pressures.

CAUTION Do not exceed the rated load capacity of the suspension system or other components. Exceeding the capacity can cause component failure and void the warranty.

Air Control Kit (ACK) Components - Liftable Axle

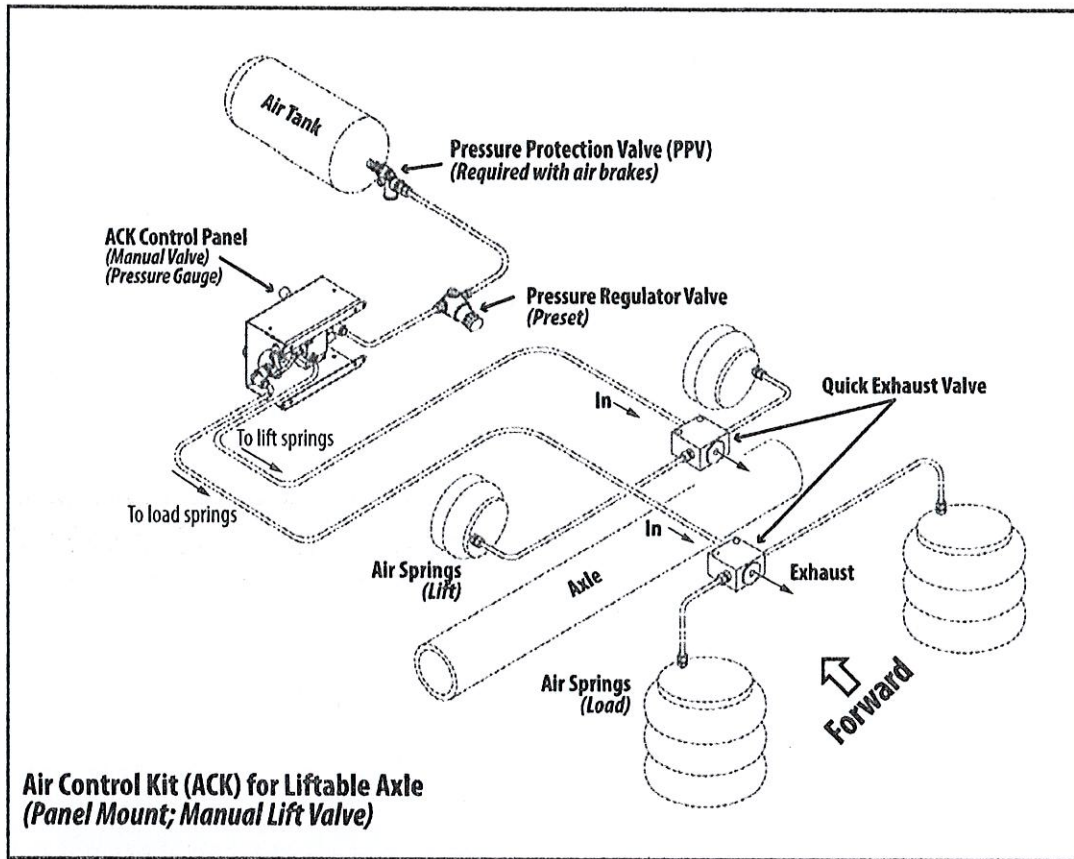

The air control kit consists of a pressure regulator with a gauge; connected to an air valve that is operator-controlled by a manual knob or by an electric switch.

The operator uses the air control kit to control the pressure to the air springs to support different loads.

Contact Ridewell Customer Service for the various manual/electric ACK configurations available. Installation will vary by ACK configuration.

CAUTION The installer is responsible for ensuring air system requirements comply with the appropriate Federal Motor Vehicle Safety Standards.

Air Control Kit – Troubleshooting

Problem	Possible Cause	Solution
Air springs fill but do not exhaust.	<ul style="list-style-type: none"> Obstructed air line. Faulty controls wiring. Manual override pushed in. 	<ul style="list-style-type: none"> Check for pinched/blocked lines. Check wiring with voltmeter and correct wiring/installation. Release manual override.
Air system leaks down after a short period of time.	<ul style="list-style-type: none"> Leak in air system beyond accepted standards. NOTE: Some valves will leak at an acceptable rate. 	<ul style="list-style-type: none"> Pressurize system and spray soapy water solution onto the tubing, valves and fittings. Check for bubbles (leaks). Check that tubing cuts are straight and smooth. Re-cut and reassemble fitting joints, if necessary.
Auxiliary unit will not stay up	<ul style="list-style-type: none"> Loose air fitting connection/Damaged air lines. Air lines to lift and load air springs are reversed. Damaged or worn air springs. 	<ul style="list-style-type: none"> Check and retighten fittings. Repair or replace component, as necessary. Check installation. Air line from regulator goes to (load) air springs. Replace air spring if worn or damaged.
Auxiliary unit not achieving correct lift	<ul style="list-style-type: none"> Air lines to lift and load air springs are reversed. Lift air springs do not have proper air pressure. Interference with driveline/other chassis components. Air control system not installed correctly. 	<ul style="list-style-type: none"> Check installation. Air line from regulator goes to (load) air springs. Check for loose fittings or worn/damaged lines. Verify air tank pressure with gauge. Visually inspect auxiliary unit operation for proper clearance. Retighten any loose fasteners. Check air control kit installation; refer to OEM installation procedures.

Recommended Service Intervals

Ridewell Suspensions recommends these minimum service intervals for standard duty, on-highway usage applications. More frequent intervals are recommended for heavier duty applications.

Daily/Pre-Trip Inspections

- ___ Check tires for proper inflation, damage or excessive wear.
- ___ Check wheel-ends for obvious signs of lubricant leakage. Check for missing components.
- ___ Check axle assemblies for damage/loose components.
- ___ Visually inspect suspension structure for signs of damage or excessive wear.
- ___ Check for loose or missing bolts/nuts. Check for irregular movement in suspension components.
- ___ Make sure air controls are operating properly. Drain all moisture from air reservoirs.

First 6,000 miles of use

- ___ Torque suspension components to specifications (Pg 12/Engineering Drawing).
NOTE: Do not re-torque shear-type pivot bolt.
- ___ Verify the suspension is operating at the designed ride height.

Refer to these Technology & Maintenance Council (TMC) publications for maintenance information

- RP 609 Brake Adjuster Installation/Maintenance
- RP 618 Wheel Bearing Adjustment Procedure
- RP 619 Air System Inspection Procedure
- RP 622 Wheel Seal and Bearing Removal, Installation, and Maintenance
- RP 631 Recommendations for Wheel End Lubrication
- RP 643 Air Ride Suspension Maintenance Guidelines
- RP 728 Trailer Axle Maintenance

Every 12,000 miles of use

- Inspect air springs for damage/excessive wear. Torque bolts/nuts to spec (Pg 12/ENG Drawing).
- Check air lines and connections for leaks.
- Lubricate Brake Cams and Slack Adjusters.

First 50,000 miles of use

- ___ Torque suspension components to specifications (Pg 12/Engineering Drawing).
NOTE: Do not re-torque shear-type pivot bolt.
- ___ Check wheel ends for excessive play.

Annually/100,000 miles of use

- ___ Inspect pivot connections for worn pivot bushings and replace, if necessary. Torque pivot hardware and component bolts/nuts to specifications (Pg 12/ENG Drawing).
- ___ Check suspension hanger and air spring mounting plate connections to frame.

Check lubrication level in wheel ends:

- ___ 1) Oil-Filled Wheel Ends:
Refill/Replace lubricant as needed (TMC RP 631 "100K/Annual Inspection").
- ___ 2) Semi-Fluid Grease:
Pull outer bearing and visually inspect lubrication level. Refill/Replace as needed (TMC RP 631 "Level 3 Lubrication Level Inspection" (TMC RP 618 "Wheel Bearing Adjustment").
- ___ Check air system for leaks.
- ___ Test air system pressure protection valve (if equipped).
- ___ Check brake chambers and brakes for damage and proper function.

CAUTION Failure to torque bolts/nuts of suspension components to specifications can result in failure of the suspension and void the warranty.

Pivot Bushing Inspection Procedure

The pivot bushing can be checked without disassembling the suspension. Park the unloaded trailer on a level surface. Set the brakes and chock the tires so vehicle cannot move during inspection.

Insert the flat end of a pry-bar between one side of the hanger sidewall and the wear washers. Move the pry-bar back-and-forth and look for excessive movement of the beam (NOTE: A small amount of beam

movement because of the rubber flexing is normal). Inspect the wear washers for excessive wear/damage.

Repeat the pry-bar process and wear washer inspection on the other side of the hanger. If any large/easy movement or damaged wear washers is observed, drop the beams for further inspection. Replace components as necessary.

RCA-215 TRUCK – AIR SPRING MOUNTING PLATE/SPACER INDEX

**NOTE: The same size of hanger spacer must be installed with the air spring spacer:
 1" Hanger Spacer – 8003434 2" Hanger Spacer – 8003435**

Manufactured before October 2014

**(Stamped) Mounting Plate
 Included with Air Spring**

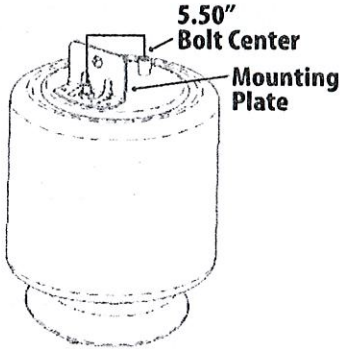

Air Spring – 1001R12444G

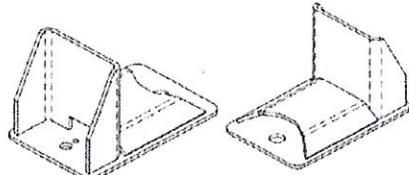

3450126-1" Mounting Spacer

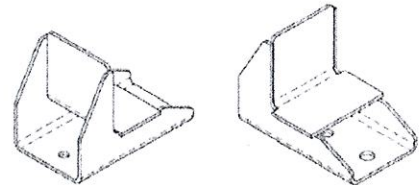

3450155-2" Mounting Spacer

Manufactured Oct. 2014–Feb. 2017

**Upper Air Spring Mounting Plate (Standard)
 3450154**

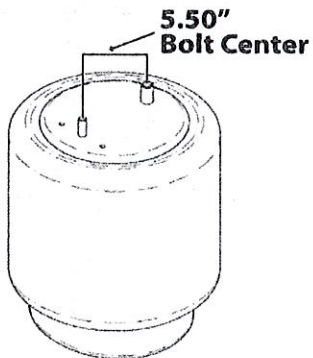

Air Spring – 1001R12653G

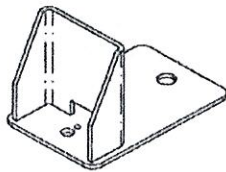

3450126-1" Mounting Spacer

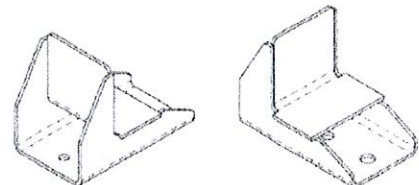
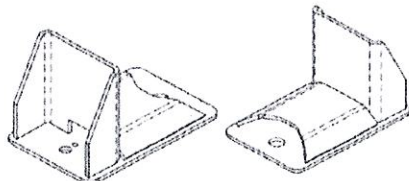

3450155-2" Mounting Spacer

Manufactured after March 1, 2017

**Upper Air Spring Mounting Plate (Standard)
 8003809**

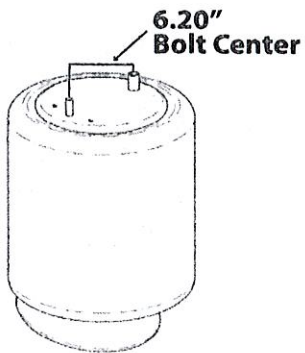

Air Spring – 1001R121202

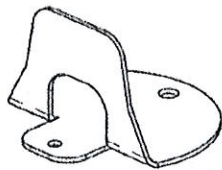

3450266-1" Mounting Spacer

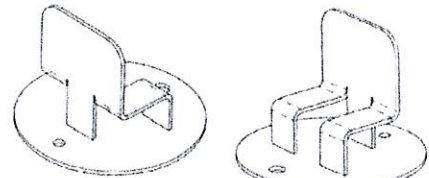
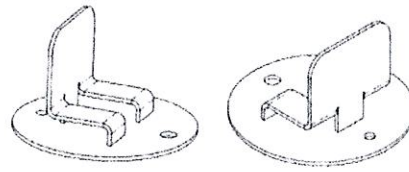

3450267-2" Mounting Spacer

RCA 215 TRUCK SUSPENSION — BUSHING REPLACEMENT/TORQUE SPECIFICATIONS

Part Number (Component)	Item Description	Size	Torque Values	
			foot-pound	Newton-meter
6040128-Bushing Kit 6100044-Narrow Tool	Pivot Bolt/Nut - (Shear-Type Bolt/Locknut) <i>Requires E-20 Torx® socket (RW #6100054)</i>	7/8"-9NC	Do not lubricate bolt/nut threads. Use 1"-drive impact wrench to tighten until Torx® head shears.	
6040078-Bushing Kit 6100044-Narrow Tool	Pivot Bolt - Hex Head Cap Screw (HHCS) Pivot Nut - (Locknut)	7/8"-9NC	500 ft-lb	678 N-m
Fasteners	Locknut - (Air Spring)	1/2"-13NC	25 ft-lb	35 N-m
	Locknut - (Air Spring)	3/4"-16NF	50 ft-lb	68 N-m
	Locknut - (Crosschannel)	1/2"-13NC	45-50 ft-lb	61-68 N-m
	HHCS/Locknut - (Optional Shock Absorber)	3/4"-10NC	160-200 ft-lb	217-271 N-m

Torque values reflect a lubricated thread condition (Nuts are pre-lubed). Do not overtorque.

CAUTION Suspension is shipped with minimal torque applied to fasteners. All fasteners must be re-torqued after first 6,000 miles of operation. Failure to install and maintain fasteners at torque specifications could result in suspension failure and void the warranty.

Vehicle Preparation

Park vehicle on a level surface. Chock wheels to keep vehicle from moving.

Raise vehicle to a height that removes the load on the suspension. Support with jack stands.

Disconnect the linkage from the height control valve(s), if equipped. Exhaust all air from the system.

CAUTION Failure to properly chock wheels, exhaust the air system and safely support the vehicle could allow vehicle/suspension movement that could result in serious injury.

Disassemble the suspension

Remove wheels and tires, if necessary. Remove the shock absorbers (if equipped).

Take the pivot connections apart. Remove and discard pivot bolt, flat washer and pivot nut. Inspect adjuster plate and alignment washer for wear/damage. Replace if necessary.

CAUTION Do not reuse pivot hardware.

Rotate beams down and away from frame. Inspect pivot-bolt holes and wear washers for unusual wear/damage. Repair or replace components as needed.

continued on next page

**P/N 6100044
Narrow Bushing
Replacement Tool**

No.	Part No.	Item Description
1	1130088	HEX HEAD CAP SCREW (HHCS) 7/8"-6; 18" GR5
2	1160036	FLAT WASHER — 7/8" F436 ZINC COATED
3	1120051	BEARING COLLAR
4	1660009	THRUST BEARING
5	6100089	ENDCAP — NARROW BUSHING TOOL
6	6100092	CONE ASSEMBLY — NARROW BUSHING TOOL
7	6100091	PLUNGER — NARROW BUSHING TOOL
—	1980014	EXTREME PRESSURE LUBRICANT

Replacement Procedure with Narrow Bushing Tool #6100044 (continued)

Tool Assembly

Check that thrust bearing is installed in the flat, outside edge of endcap. Inspect tapered insert and endcap for damage. Repair or replace as needed.

Lubricate Hex-Head Cap Screw and thrust bearing threads with Extreme Pressure Lubricant (#1980014).

Thread the flat washer, the bearing collar and the endcap onto the HHCS until the bearing collar and endcap rest against the head of the HHCS. Place tool cone onto endcap (Figure 7).

NOTE: Failure to apply lubricant to the threads could result in decreased tool performance and reduce the life of the bushing tool.

Bushing Removal

1. Push the HHCS through the inner sleeve until the tool cone is against the beam eye. Thread the plunger onto the HHCS until the tool cone is held firmly against the beam (Figure 7).

NOTE: Tapered end of cone is placed against the beam eye for both removal and installation.

2. Check that tool cone is centered on the beam eye. Use a 1 5/16" socket on a 3/4"-drive impact wrench (1"-drive impact wrench recommended) to rotate HHCS and pull the bushing into cone.

NOTE: In some cases, a small amount of heat may be needed to break the bond between the bushing and beam eye.

Do not overheat. Allow the beam to cool before installing replacement bushing.

3. Remove bushing tool from the beam. Detach tool cone from endcap, remove bushing and discard.

continued on next page

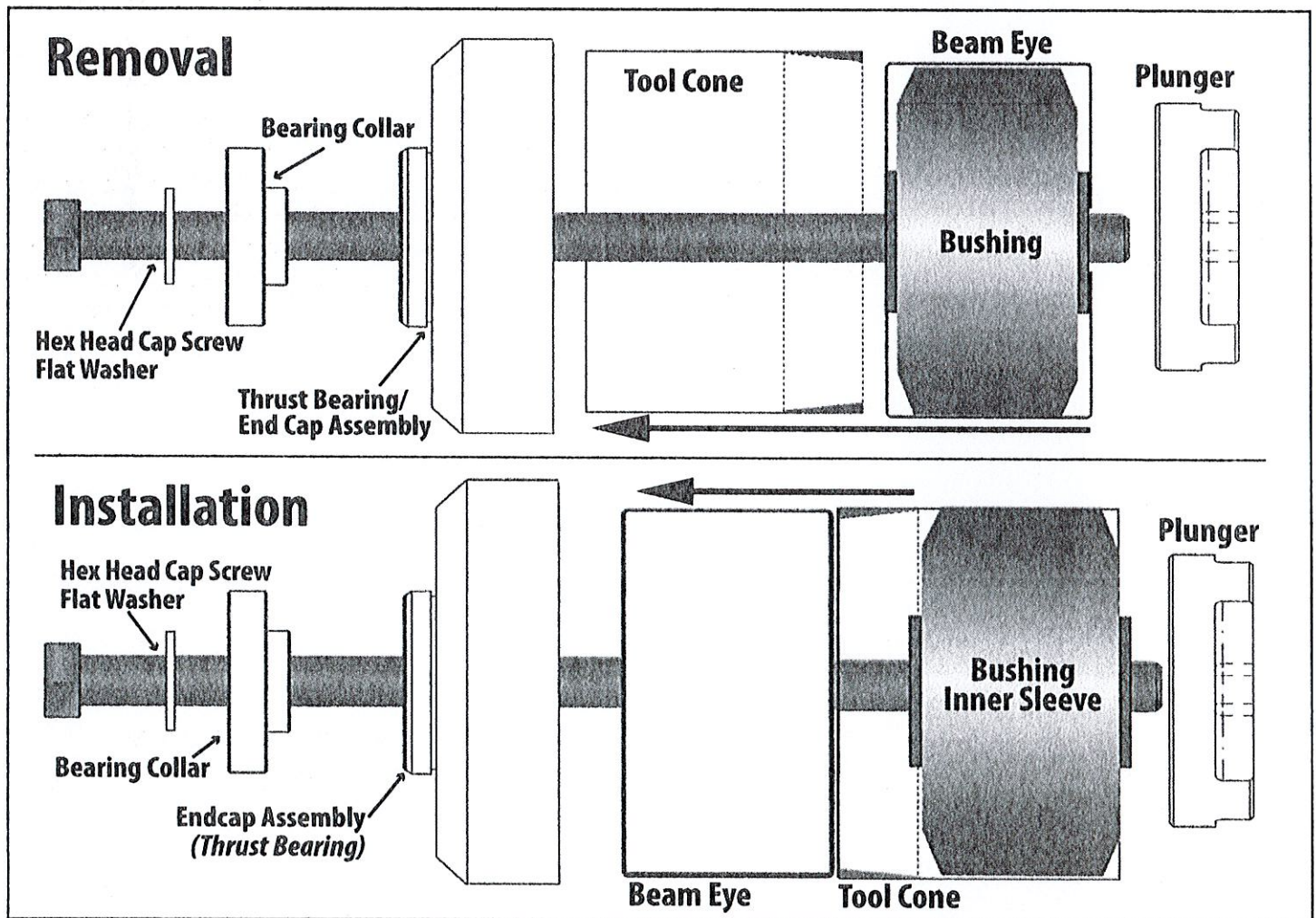

Figure 7.

Place tapered end of cone against beam eye for bushing installation and removal.

Replacement Procedure with Narrow Bushing Tool #610044 (continued)

Tool Assembly

Thread the flat washer, the bearing collar and the endcap onto the hex-head cap screw until the bearing collar and endcap rest against the head of the HHCS.

Bushing Installation

1. Use wire brush to clean debris /corrosion from eye.
2. Liberally apply P80[®] lubricant or a soap solution to the inside of the beam eye, the outside of the new bushing and inside the tool cone. Insert replacement bushing into the larger opening of the tool cone (Figure 8).
3. Center the smaller opening of the tool cone against beam eye. Push the hex-head cap screw through the bushing inner sleeve from the opposite side of the beam until the endcap rests against the beam eye.
4. Thread the plunger onto the hex-head cap screw until tool cone is held firmly against the beam. **NOTE:** The smaller opening of the tool cone is placed against the beam eye for both removal and installation of the bushing.
5. Verify that bushing tool cone is centered on the beam eye. Use a 1 5/16" socket and 3/4"-drive impact wrench (1"-drive impact wrench recommended) to rotate the hex-head cap screw and press the bushing into the beam eye.
6. Disassemble and remove bushing tool from the beam. Verify bushing is centered inside the beam. Realign bushing if necessary.

Reassemble suspension

Rotate the beams into hangers.

Assemble the pivot connection – alignment washer, adjuster plate, wear washers, shear-type pivot bolt, flat washer and flanged locknut.

NOTE: Do not lubricate pivot bolt/nut.

Tighten locknut until adjuster plate pin is engaged and pivot connection hardware is snug against the hanger. Do not apply final torque until the axle alignment has been checked.

Install the shock absorbers (if equipped).

Connect the height control valve linkage (if linkage has been disconnected). Inflate air springs.

Install wheels and tires (if removed). Raise the vehicle and remove support stands. Lower vehicle to ground.

Verify the suspension ride height. Check axle alignment. Realign if necessary (Pg 15).

Tighten pivot bolt with a 1" drive impact wrench and E-20 Torx[®] socket (Ridewell tool #610054) until Torx[®] head is sheared off.

CAUTION Failure to torque hardware to specifications can result in suspension failure/void the warranty.

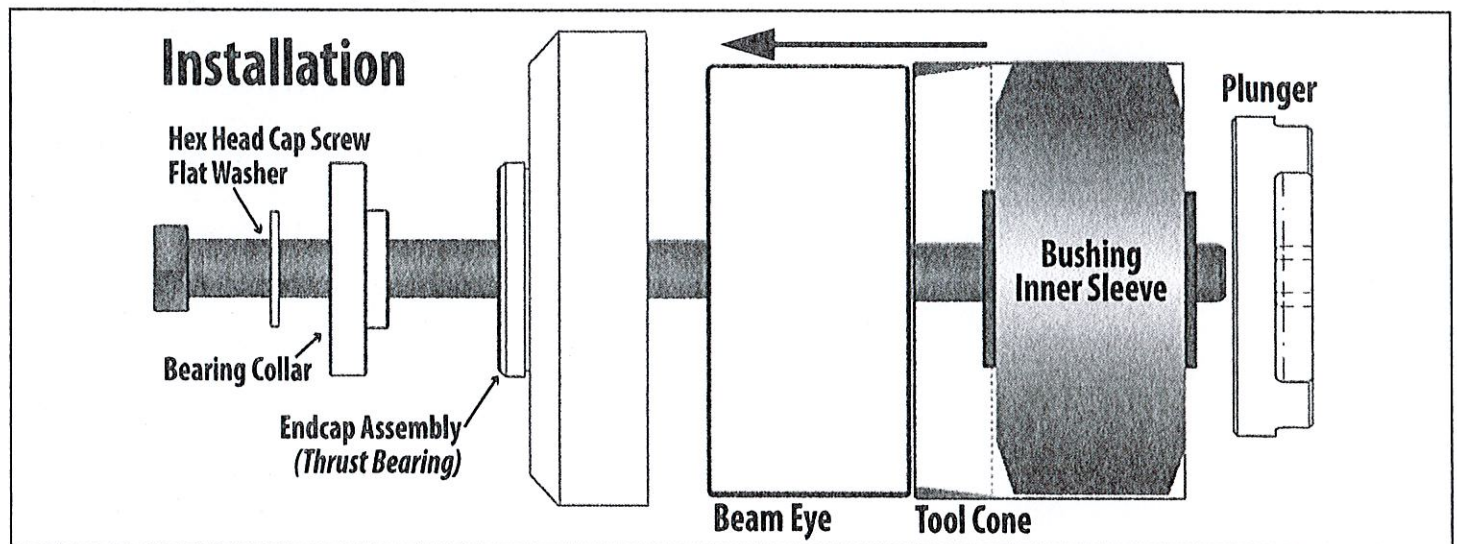

Figure 8.
Place the tapered end of the cone against the beam eye for bushing installation and removal.

Axle Alignment

Alignment should be performed on a level surface with the suspension at the desired ride height. Align the suspension per TMC- or SAE-recommended standards.

On a multiple-axle vehicle, the forward axle is moved into proper alignment, then the remaining axles are positioned so that they are parallel to the forward axle. A maximum tolerance of 1/8-inch difference from side-to-side of the forward axle and 1/16-inch difference from side-to-side for the aft axles is acceptable (Figure 9).

The RCA 215 Suspension is equipped with the Ridewell Speed Set® alignment feature for manual alignment.

Figure 9. Kingpin measurement for axle alignment.

Check the forward axle alignment by measuring from the kingpin to both ends of the axle centers.

If the difference between the "A" measurement and the "B" measurement is greater than 1/8-inch, the forward axle needs to be aligned.

Adjust the aft axle if the difference between the "C" measurement and the "D" measurement is greater than 1/16-inch.

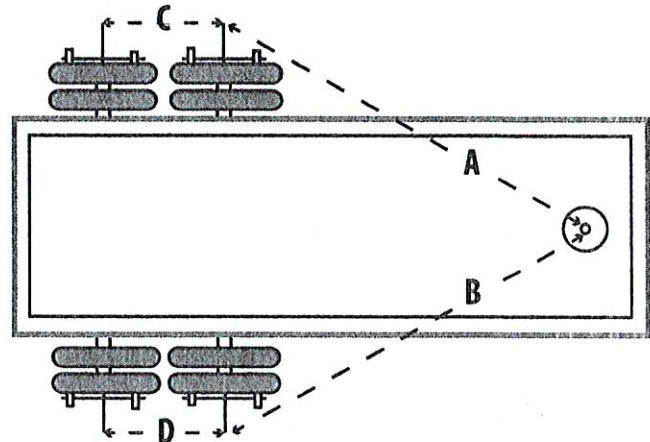

Axle alignment procedure

1. Loosen the pivot nut enough for the beam to move within the hanger (Figure 10).
CAUTION Do not reuse pivot hardware if Torx® head is damaged or missing. A new shear-type pivot bolt, flat washer and locknut must be installed and the Torx head sheared off to complete the alignment.
2. Locate the adjuster plate at the pivot connection. Insert a 1/2"-shank breaker bar into the square hole of the adjuster plate. Push on the breaker bar to move the beam forward or backward until the axle reaches alignment measurements (Figure 9).
NOTE: Verify the pivot bushing is not wedged sideways during beam movement. The adjuster plate and alignment washer should move in unison with beam movement.
3. Tighten the pivot nut so that the beam can no longer move. Re-check alignment measurements and adjust if necessary.
NOTE: Check to make sure both the adjuster plate and alignment washer are flat against the hanger before final torque is applied.
4. Tighten pivot bolt with a 1"-drive impact wrench and E-20 Torx® socket (Ridewell tool #6100054) until the Torx® head is sheared off.

CAUTION Failure to properly torque pivot hardware could result in suspension failure and void the warranty.

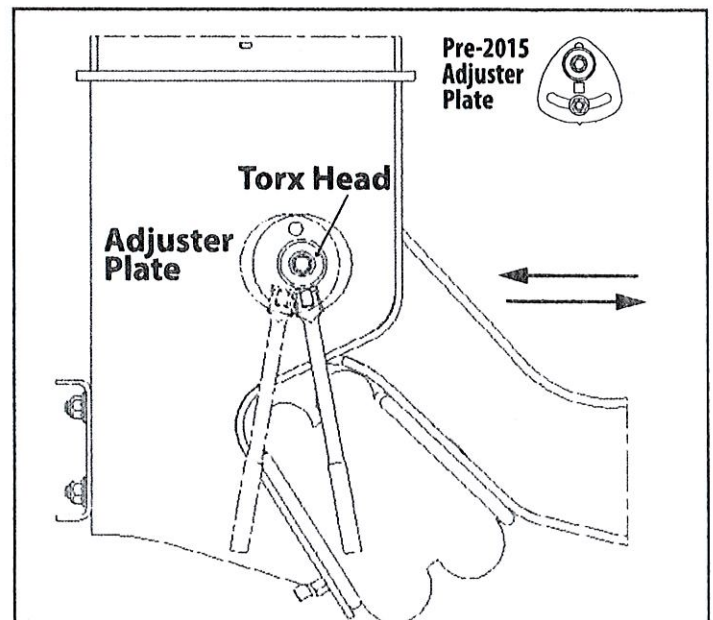

Figure 10.
Move beam back-and-forth using breaker bar until the axle reaches the desired position.

Terms and coverage in this warranty apply only to the United States and Canada.

Ridewell Suspensions warrants the suspension systems manufactured by it to be free of defects in material and workmanship. Warranty coverage applies only to suspensions that have been properly installed, maintained and operated within the rated capacity and recommended application of the suspension. The responsibility for warranty coverage is limited to the repair/replacement of suspension parts. The liability for coverage of purchased components is limited to the original warranty coverage extended by the manufacturer of the purchased part.

All work under warranty must have prior written approval from the Ridewell warranty department. Ridewell has the sole discretion and authority to approve or deny a claim and authorize the repair or replacement of suspension parts. All parts must be held until the warranty claim is closed.

Parts that need to be returned for warranty evaluation will be issued a Returned Materials Authorization (RMA). Parts must be returned to Ridewell with the transportation charges prepaid. The transportation charges will be reimbursed if the warranty claim is approved.

This non-transferable warranty is in lieu of all other expressed or implied warranties or representations, including any implied warranties of merchantability or fitness or any obligations on the part of Ridewell. Ridewell will not be liable for any business interruptions, loss of profits, personal injury, any costs of travel delays or for any other special, indirect, incidental or consequential losses, costs or damages.

Contact the Ridewell Warranty Dept. at 417.833.4565 - Ext. 135, for complete warranty information.

INVITATION TO BID HEAVY EQUIPMENT

LE
Automatic

NOTICE OF BID OPENING

NOTICE IS HEREBY GIVEN that the Association of County Commissions of Alabama, which administers the Alabama County Joint Bid Program on behalf of Alabama's county governing bodies, shall receive and open bids for the purchase of zero (0) or more items of heavy road equipment at its office located at 2 North Jackson Street, Montgomery, Alabama, at **10:00 a.m. on Friday, October 7, 2022**. Bid specifications are available at <http://www.alabamacounties.org/heavy-equipment/> for each of the following items:

Backhoes
Tractors
Track Mount Excavators
Compact Track Mount Excavators
Mini Track Excavator
Wheeled Excavators
Highway Speed Truck Excavators
Motor Graders
Heavy Duty Hydrostatic Bulldozers
Mulching Dozer
Wheel Loaders
Heavy Duty Dump Chassis
Lowboy Tractors
Skid Steer Loader w/no Attachments

Skid Steer Attachments
Ride-on Industrial Boom Mowers
Asphalt Distributor Truck
Chip Spreader
Rubber Tire Roller
7.5 Ton Single Drum Vibratory Roller
One-man Pothole Patchers
Trailer Mounted Patchers
Trailer Mount Mastic Patcher/Crack Sealer
Half Round End Dump Trailer
Lowboy Trailers
Road Wideners and Attachments
16' Steel Dump Bodies (Automatic and Manual)

Time is of the essence in submitting bids and only bids received in the Association office by 10:00 a.m. Central Time on Friday, October 7, 2022 will be opened and considered. Bidders and any other interested individuals are invited to attend the bid opening.

NOTICE OF BID OPENING PROCEDURES

All bids for **Heavy Equipment** will be opened and the name(s) of the bidders read aloud on the morning of the bid opening on Friday, **October 7, 2022 at 10:00 a.m.** at 2 North Jackson Street, Montgomery, AL. The specifics of each bid submitted will be compiled by the Association staff thereafter and will be available, **upon written or emailed request**, one week after the bid opening. Requests should be emailed to jointbid@alabamacounties.org.

THE INVITATION PACKAGE

The invitation package for each item to be bid includes: this invitation to bid, the written bid specifications for the particular item of heavy road equipment, and a Bid Submittal Form to be used in submitting a bid for that particular item. Bidders should verify that they have received all pages of the invitation package. If there are any omissions, the bidder should contact Kenya Howard in the Association office by mail, fax, or e-mail (jointbid@alabamacounties.org) to request missing pages. It is the responsibility of the bidder to make this request in sufficient time to prepare and submit the bid in time for the bid opening. Bidders should carefully read and comply with all parts of the invitation package, including all attachments and/or any addendum.

PREPARING AND SUBMITTING BIDS

All bids must be typed or hand written in ink on the attached Bid Submittal Form. **The completed Bid Submittal Form shall be placed in front of and separated from all other documents included in the bid packet, such that it will be the first document viewed upon opening the bid packet.**

Bids submitted in pencil and bids not submitted on the Bid Submittal Form will **not** be considered. All bids shall include a current catalog or model specification document for the equipment model number being offered for consideration. Bids submitted without such documentation will **not** be considered. Only information contained on the attached Bid Submittal Form and in the model specification document will be considered in evaluating bids.

Each separate requirement in the bid specification includes a block for indicating whether or not the item bid meets the specification. The bidder shall indicate compliance with each requirement by checking "Yes" or "No" in the block to the right of each bid specification. In addition, the bidder shall indicate the page number in the supplied manufacturer's equipment literature on which compliance with the specification can be verified. Failure to complete this portion of the bid form may result in the subject bid not being considered. Additionally, all bidders are required to submit a factory build/order sheet showing all of the standard and option items for each piece of equipment bid in order to assist the bid review committee in assuring that each bid is in conformance with the required bid specifications.

Each bid for one of the heavy equipment items included in the bid package must be submitted on the Bid Submittal Form for that item and forwarded in a separate envelope with the bid item and item number clearly identified on the outside of the envelope. Envelopes containing a "no bid" shall also include the words "NO BID" on the outside of the envelope. Facsimiles and e-mails will not be accepted. Bids submitted by "Express/Overnight" services must be in a separate inner envelope or package sealed and identified as stated above. All bids must be received in the Association office prior to the bid opening. Bids received after the deadline will be returned unopened.

The County Joint Bid Program reserves the right to require a performance bond from successful bidders as permitted under Alabama law. However, **no bid bond is required for this bid offering.**

All bids should be mailed or hand-delivered to:

ATTN: Joint Bid Program
Association of County Commissions of Alabama
2 North Jackson Street, FL 7, Montgomery, Alabama 36104 (Physical Address)
P.O. Box 5040, Montgomery, Alabama 36103 (Mailing Address)

BID SPECIFICATIONS

Please note that each piece of heavy equipment available for bid may include several different sizes and categories of machines. You should read each set of specifications very carefully as the differences vary depending upon the piece and size of equipment.

Where applicable, each bid submission shall include the separate cost of each item listed in the "Options" section of the bid specifications. However, all bids will be awarded on the basis of the **total cost of the machine with all options included**. Therefore, the "Bid Price" stated on the Bid Submittal Form must be the total cost, including the cost of all options.

Once the bids have been awarded, any county participant purchasing under this program may, at its discretion, deduct one or more of the options set out in the bid specifications, and in such event, the cost of the option as stated on the bid shall be deducted from the total cost of the machine. There shall be no other deductions and no additions made to the machine by the purchasing county or by the vendor.

Any use of specific names and/or model numbers in the attached specifications is not intended to restrict the bidder or any seller or manufacturer, but is included solely for the purpose of indicating the type, size, and quality of materials, product services, or equipment considered best adapted to the use of the counties participating in the joint bid program.

BIDDER QUALIFICATIONS

All bidders and all program participants must be in compliance with any applicable federal, state, county and municipal laws, regulations, resolutions and ordinances, including but not limited to, licensing, permitting, and taxation requirements. All bidders should be prepared to submit evidence or documentation as proof that they are properly licensed and permitted under any applicable laws upon request. Such evidence or documentation may be submitted with the bid. Additionally, all bidders shall provide proof that they are in compliance with the e-verify requirements of Alabama's Immigration Law (Ala. Code § 31-13-1 et seq., as amended by Act No. 2012-491).

BID AWARD

The Houston County Commission will serve as the awarding authority for all bids and will award all contracts at a regular meeting of the Houston County Commission. Any and all bids submitted in compliance with this invitation to bid shall be considered, and award will be made to the lowest responsible bidder meeting bid specifications as determined by the awarding authority in compliance with Alabama law. All bids will be reviewed and evaluated by a committee created for that purpose, which committee will make comments and recommendations to the awarding authority regarding the award. All factors contained in each invitation package will be evaluated in determining the successful bidder, and any omissions of the stated requirements may be cause for rejection of the bid submitted. The awarding authority reserves the right to reject any and all bids, to waive any informality in bids, and to accept in whole or in part such bid or bids solely at its discretion.

The contract period will be one year with an option to renew for a second and third year under identical price, terms, and conditions upon the mutual consent of the vendor and the awarding authority. Any renewal contract shall be approved in writing by the vendor and the awarding authority no later than 90 days prior to the expiration of the existing contract.

CONTACT REGARDING BIDS AND INVITATION

Contact initiated by a potential bidder with any county official, county employee, or member of the Association staff shall only be as specifically set out in this Invitation to Bid. Any questions related to the bid or the County Joint Bid Program shall be directed to Association staff in writing under the procedures set out in this Invitation to Bid. Additionally, a bidder may contact the Association in writing to request an appointment to review bid specifications following the bid opening. **However, there shall be no communication with any county official or county employee regarding this bid between the date of this invitation and the date of bid award.** Any contact other than as set out here shall be deemed as an attempt to unduly influence the bid award, and shall be grounds for rejection of the bid submitted by the bidder initiating such other contact.

Any questions or problems related to downloading or obtaining copies of this Invitation to Bid should be directed to **Kenya Howard** at jointbid@alabamacounties.org or **334-263-7594**.

Any other questions or requests for additional information regarding this invitation or the bid specifications shall be submitted **in writing** no later than five (5) days prior to bid opening to:

ATTN: Patrick McDougald
Association of County Commissions of Alabama
P.O. Box 5040
Montgomery, Alabama 36104

OR

Patrick McDougald
E-mail: barbeng@bellsouth.net



Logan LE Dump Body



FEATURES:

- Elliptical tub floor with AR450 steel
- Cross-memberless
- Axalta automotive quality finish
- Rides on rubber cushion
- Configurations from ultra-light to heavy duty
- Rear hinge with full-width pin
- LED lights
- Flame-cut all steel hardware and hinge, no castings

OPTIONS:

- Lengths from 10'-30'
- Side heights from 36"-64"
- High lift gate in two configurations
 - External Cylinders
 - Cylinders in rear post
- Side swing gate
- One-piece aluminum diamond plate fender covers
- Weld-on or Bolt-on Apron
- Straight, sloped, or asphalt-tapered rear
- Sloped front with externally-mounted hoist



Logan Corporation
124 Ward Road
Salyersville, KY 41465
Phone: 606.349.1744
Fax: 606.349.1144
www.logandumpbodies.com



Logan LE Dump Body



Whether you're hauling dirt or demolition, asphalt or rock, Logan's LE dump body gets the job done. The LE is a multi-purpose body that uses a unique shaped floor and sides to maximize capacity. This shape also deflects impact and increases rigidity, which in turn offers great resistance to the wear and tear of tough jobs.