

BID SUBMITTAL FORM
Alabama County Joint Bid Program
Heavy Equipment – Bid Items: 3.65 CY Wheel Loader - Option A

Company Name: THOMPSON TRACTOR COMPANY

Address: P.O. BOX 10367
BIRMINGHAM, AL 35202-0367

Bid Submitted by: JAY SMITH
(Name of company representative)

Title: SALES OPERATIONS MANAGER E-mail address: JAYSMITH@THOMPSONTRACTOR.COM

Phone: (205) 849-4242 Fax: _____

By submitting this bid, we agree:

Initials

The equipment model number identified below meets the bid specs for this bid item

JAS

That the bid price will be honored for all counties for the period from January 1, 2023 to December 31, 2023.

JAS

The equipment will be delivered at the bid price to all counties participating in the joint bid program.

JAS

The company acknowledges the freight preparation and delivery price is to be included in the total bid price for the standard machine.

JAS

The company representative listed above will be the contact person for purchasing this bid item under the joint bid program.

JAS

The bid is accompanied by a current catalog or model specification document for the model number identified below.

JAS

The bid is accompanied by a copy of the manufacturer's standard warranty as required in the bid specifications.

JAS

The bid includes the e-verify documentation required by Alabama law.

JAS

If awarded the bid, a performance bond will be provided upon request.

JAS

The bid documents include the **Manufacturer's Suggested Retail Price Sheet (MSRP) for the Standard Machine.**

JAS

Total Bid Price for Standard Machine: \$ 280,949
(Total Bid Price for Standard Machine Includes Freight Preparation, Delivery and Standard Warranty Costs) *

Freight Preparation and Delivery: \$ 8,053
(Included in Standard Machine Bid Price)

Manufacturer's Suggested Retail Price for Standard Machine: \$ 385,446

Equipment Model #: CATERPILLAR 938M

Description: WHEEL LOADER

Signature of company representative submitting bid: 

Title: SALES OPERATIONS MANAGER

***NOTE:** Award will be made based on the total cost of the **Standard Machine**. The total cost of the standard machine is to include the freight preparation, delivery and standard warranty cost. Freight preparation, delivery will be excluded from the total bid price of the standard machine in determining the percentage discount for any available options.

BID SUBMITTAL FORM: OPTION COST SHEET

By submitting this bid, we agree:

To offer any available options at the percent difference between the Manufacturer's Suggested Retail Price Sheet and the actual bid price on the Standard Machine*

QAS

The bid documents include the **Manufacturer's Suggested Retail Price Sheet (MSRP)** for the Standard Machine

QAS

Equipment Model #: CATERPILLAR 938M

Description: WHEEL LOADER

Signature of company representative submitting bid: 

Title: SALES OPERATIONS MANAGER

***NOTE:** The percent difference between the **Manufacturer's Suggested Retail Price Sheet (MSRP)** for the standard machine as specified by these **Bid Specifications** and the actual price bid by the vendor will be calculated to determine the percentage discount to be applied to any available options. The bid price of the freight preparation, delivery cost shall be excluded in determining the percentage discount to be applied to available options. Any individual county may choose to add any available option to the standard machine at the percentage discount at the time of purchase.

938M	3.65 CY WHEEL LOADER OPTION A	2023 Pricing
541-2673	938M WHEEL LOADER	\$327,610
430-2943	PREP PACK FOR UNITED STATES	\$0
333-6858	STANDARD STEERING	\$0
349-8014	OPEN REAR DIFFERENTIAL	\$0
536-5320	STANDARD ENVIRONMENT (dustbowl precleaner & standard fan)	\$0
454-0612	STANDARD WEATHER	\$0
527-0422	TF FINAL ENGINE	\$0
536-5341	2 VALVE PIN-ON HYDRAULICS, STANDARD LIFT	\$0
536-5284	STANDARD HYDRAULICS	\$0
536-5329	NO AUXILIARY LINES	\$0
536-5339	NO JUMPER LINES	\$0
488-1112	STANDARD HALOGEN LIGHTS	\$0
541-3066	HALOGEN ROADING LIGHTS	\$0
549-0451	DELUXE CAB (INCLUDES REAR VIEW CAMERA)	\$5,707
563-5967	DELUXE AIR SUSPENSION SEAT	\$1,486
372-1868	AM/FM BLUETOOTH RADIO	\$1,028
565-0908	CELLULAR PRODUCT LINK PL641	\$0
366-6882	20.5-R25 MX * XHA2 * L3 MICHELIN TIRES	\$24,019
366-8150	STANDARD FENDERS	\$0
467-7990	HEAVY COUNTERWEIGHT	\$3,735
491-7922	TOOLBOX	\$706
421-8926	SERIALIZED TECHNICAL MEDIA KIT	\$0
430-2860	RIDE CONTROL	\$5,644
349-8163	CRANKCASE GUARD	\$1,339
345-2828	3.80 YD3 PIN ON GP BUCKET W/ BOLT ON CUTTING EDGE	\$14,172
	TOTAL BID PRICE FOR STANDARD MACHINE	\$280,949
	FREIGHT PREPARATION AND DELIVERY	\$8,053
	TOTAL MANUFACTURER'S SUGGESTED RETAIL PRICE FOR STANDARD MACHINE	\$385,446

**BID SPECIFICATIONS
FOR
3.65 CY WHEEL LOADER – OPTION A**

GENERAL

These specifications shall be construed as the minimum acceptable standards for a 3.65-yard wheel loader. Should the manufacturer's current published data or specifications exceed these standards, the manufacturer's standards shall be considered minimum and shall be furnished. All integral parts not specifically mentioned in the scope of these specifications that are necessary to provide a complete working unit shall be furnished. Additionally, the machine offered for bid shall include all standard manufacturer's equipment. The wheel loader must be a new current production model and shall meet all EPA and other applicable standards at the time of manufacture.

The use of specific names and numbers in the specification is not intended to restrict the bidder or any seller or manufacturer, but is intended solely for the purpose of indicating the type, size and quality of equipment considered best adapted to the uses of counties participating in this joint bid.

BID SUBMITTAL FORM

Each bidder must submit his or her bid on the Bid Submittal Form included in the Invitation to Bid package. All written warranties to be submitted shall be attached to the Bid Submittal Form.

BID PRICE

The bid price shall include all destination charges, delivery charges, title fees, rebates, and all other applicable costs and refunds.

MANUALS

Each unit shall be provided with one (1) copy of the operator's manual, one (1) copy of the repair manual and one (1) copy of the current parts manual. Units will not be accepted for delivery until the manuals as outlined above are received by the purchaser.

REPLACEMENT PARTS AVAILABILITY

Parts must be available for 5 years or 7,500 hours of use for the piece of equipment bid. If replacement parts are not delivered within three (3) working days of an order being placed, the bidder will deliver an equivalent machine for the county to use at no cost to the county until such time as the parts are delivered to the county so it can affect repairs on its machine.

WARRANTY

Bidders shall submit a copy of the manufacturer's standard warranty. Warranty shall include service response time of maximum of 36 hours within notification by county.

Yes No
Page# _____
or
Attachment

DUMP CLEARANCE

The wheel loader dump clearance shall be no less than 9' 3" at full height and 45-degree dump angle.

Yes No
Page # 80

GENERAL OPERATING SPECIFICATIONS AND DIMENSIONS

Straight static tipping load shall be at least **25,800 lbs.** and the Full turn static tipping load shall be at least **21,900 lbs.** with machine equipped with ROPS cab and a minimum **3.65 cubic yard** General Purpose bucket.

Yes No
Page # 22

Breakout force shall not be less than **25,000 lbs.** with the minimum 3.65 cubic yard General Purpose bucket.

Yes No
Page # 22

Machine ground clearance shall not be less than **1' 3"**.

Yes No
Page # 16

BRAKES

-Machine shall have oil cooled multiple disc-type, adjustment-free service brakes, which are outboard mounted and sealed.

Yes No
Page # 15, 35

STEERING/HITCH

Machine shall have center-point articulation with an articulation angle of at least $\pm 40^\circ$.

Yes No
Page # 16

OIL SAMPLES

Oil sample analysis shall be provided, at no cost to the county, through the standard periods. Oil sample kits are to be provided and are to include a sample gun. Oil sampling ports shall be standard for quick and clean access to various machine oils (such as hydraulic, engine oil, transmission).

Yes No
Page # 1

FRONT AND REAR FRAMES/STRUCTURES

Machine shall be equipped with a rear towing and retrieval connection.

Yes No
Page # 35

Machine shall have lifting/tie down eyes for transportation.

Yes No
Page # BID spec p. 5

Machine shall be equipped with outside toolbox.

Yes No
Page # BID SPEC A.4

ENGINE AND RELATED COMPONENTS

Engine shall be fully equipped, six cylinder, four stroke diesel type with all necessary operating accessories.

Yes No
Page # 13, 35

Engine Shall be designed and manufactured by the machine manufacturer

Yes No
Page # 1, 5

Engine shall meet or exceed current U.S. EPA Tier IV emissions levels.

Yes No
Page # 1, 5, 13

Engine shall have a total displacement of not less than **425 cubic inches**

Yes No
Page # 13

Engine shall develop at least **182 net HP** at no more than 1800 RPM. Standard engine equipment for rating shall include fan, air cleaner, water pump, lubrication oil pump, fuel pump, muffler and alternator.

Yes No
Page # 15

Engine shall develop at least **628 lb. - ft.** maximum net torque at no less than 1400 RPM.

Yes No
Page # 13

The cooling fan for the engine coolant, A/C system, hydraulic oil, and inlet air shall be hydraulically driven, electronically controlled, and temperature sensing. It shall also compensate for horsepower draw and adjust engine fuel setting to result in a constant net horsepower.

Yes No
Page # 35

The coolant level shall be able to be checked via a ground-level sight gauge.

Yes No
Page # 12

Machine shall be equipped with 24V electric system for starting and operating, with a minimum 65-amp alternator.

Yes No
Page # 35

GENERAL MACHINE CONFIGURATION

Machine basic operating weight shall not be less than **36,000 lbs.** Comparably equipped weight includes lubricants, coolant, full fuel tank, operator, General Purpose bucket with bolt-on cutting edge, 20.5-R25 tires and ROPS cab.

Yes No
Page # 1, 18

Machine shall be equipped with a minimum **3.65 cubic yard** ISO/SAE heaped General Purpose bucket with bolt-on cutting edge.

Yes No
Page # 22

Machine shall have 20.5 R25 L3 XHA traction-type tires.

Yes No
Page # 16

Machine shall have four front and two rear working lights and two rear stop and taillights.

Yes No
Page # 1, 5

Machine shall have front fenders and rear platform extensions.

Yes No
Page # 11, 55

Machine shall have a back-up alarm

Yes No
Page # 12, 55

OPERATOR'S STATION

Integral ROPS and sound suppressed cab shall be standard and shall meet both current OSHA and MSHA standards for operator and spectator sound.

Yes No
Page # 13

Machine shall be equipped with a multilevel warning system, which will signal machine and component malfunctions. System should differentiate between major and minor malfunctions. Warning system shall record occurrences of periodic malfunctions.

Yes No
Page # 35, 31, 32, 33, 34, 35
P. 3

Instrument gauges shall include digital gear range indicator, engine coolant temperature, fuel level, hydraulic oil temperature, speedometer, and transmission oil temperature.

Yes No
Page # 35

Operator's seat shall be air suspension-type with adjustments for height, weight, fore/aft and suspension dampening, and adjustable armrests on left and right.

Yes No
Page # 35

Cab shall have internally and externally-mounted rearview mirrors.

Yes No
Page # 8, 35

Cab shall have air conditioner, heater

Yes No
Page # 8, 9, 35

Machine shall be equipped with a Fire Extinguisher

Yes No
Page # vendor

Machine shall be equipped with retractable 3" seat belt.

Yes No
Page # 35

TRANSMISSION/POWERTRAIN

Transmission and other major power train components, such as the axles, shall be **designed and manufactured by the equipment manufacturer.**

Yes No
Page # 10, 15

Automatic transmission shall be of countershaft power shift design.

Yes No
Page # BID spec p. 2

Transmission shall be electronically controlled for smooth clutch modulation.

Yes No
Page # BID spec p. 2

Transmission shall automatically select gears above first. The operator shall be able to select the highest gear to which the transmission will automatically shift.

Yes No
Page # BID spec p. 2

Transmission shall offer full manual shifting option as well as auto shifting.

Yes No
Page # BID spec p. 2

Machine shall be have a minimum of **4-forward** and **4-reverse** gears and be able to achieve a speed of at least **25 mph in both forward and reverse.**

Yes No
Page # 15

Rear axle shall not have more than 20° total oscillation.

Yes No
Page # 14

Wheel loader shall be equipped with a crankcase guard.

Yes No
Page # 11

HYDRAULICS

Hydraulic pressure taps shall be provided for checking pressure in the hydraulic implements and steering systems.

Yes No
Page # 13 *Spec A.2*

Steering hydraulic system shall have a dedicated pump and be independent of the implement hydraulics.

Yes No
Page # 14

Hydraulic total cycle time shall be no more than 11 seconds, measured with a rated bucket load.

Yes No
Page # 14

Machine shall have a ground-level hydraulic sight gauge showing hydraulic fluid level.

Yes No
Page # 12

Shall have a minimum flow of **50 gallons/minute**.

Yes No
Page # 14

926M, 930M, 938M

Wheel Loaders



	926M	930M	938M
Engine Model*	Cat® C7.1 ACERT™	Cat C7.1 ACERT	Cat C7.1 ACERT
Maximum Rated Gross Power:			
ISO 14396	114 kW (153 hp)	122 kW (164 hp)	140 kW (188 hp)
ISO 14396 (DIN)	114 kW (155 hp)	122 kW (166 hp)	140 kW (190 hp)
Bucket Capacity	1.9-5.0 m ³ (2.5-6.5 yd ³)	2.1-5.0 m ³ (2.7-6.5 yd ³)	2.5-5.0 m ³ (3.3-6.5 yd ³)
Full Turn Tip Load	7524 kg (16,587 lb)	8469 kg (18,670 lb)	10 028 kg (22,107 lb)
Operating Weight	13 050 kg (28,770 lb)	14 007 kg (30,879 lb)	16 427 kg (36,216 lb)

*Engine meets U.S. EPA Tier 4 Final/EU Stage IV emission standards.

Making Your Choice Easy

Efficiently Powerful

Experience Hybrid like fuel efficiency with an intelligent hydrostatic power train and industry leading fuel savings. For your toughest and most demanding applications a new Performance Mode will boost the power and hydraulic speed.

Work Made Easy

Move more with Caterpillar's patented quick loading Performance Series buckets and optimized Z-bar linkage. The parallel lift and high tilt forces allow you to safely handle loads. Multi-function work has never been easier with dedicated pumps and a flow sharing implement valve.

Enjoy All Day Comfort

Have a seat in the M Series Small Wheel Loader and enjoy, whisper quiet sound levels, all around visibility and seat mounted joystick controls. The large spacious cab combined with Caterpillar's exclusive hydraulic cylinder damping make this the most comfortable seat on your job site.

Customize Your Experience

Meet your application requirements and individual preferences with Caterpillar's industry first Power Train Modes. Fine tune machine performance with adjustments at your fingertips through soft touch buttons and secondary display.

Configured for Success

A complete range of optional equipment gives you the versatility to configure an M Series Small Wheel Loader to be successful in your business.

Contents

Efficiently Powerful.....	4
Work Made Easy.....	6
Enjoy All Day Comfort.....	8
Customize Your Experience.....	10
Configured for Success.....	11
Service.....	12
Customer Support.....	12
Wheel Loader Specifications.....	13
Bucket Specifications.....	18
Bucket Selection Tables.....	24, 31
Operating Specifications.....	28
Supplemental Specifications.....	33
Standard and Optional Equipment.....	35

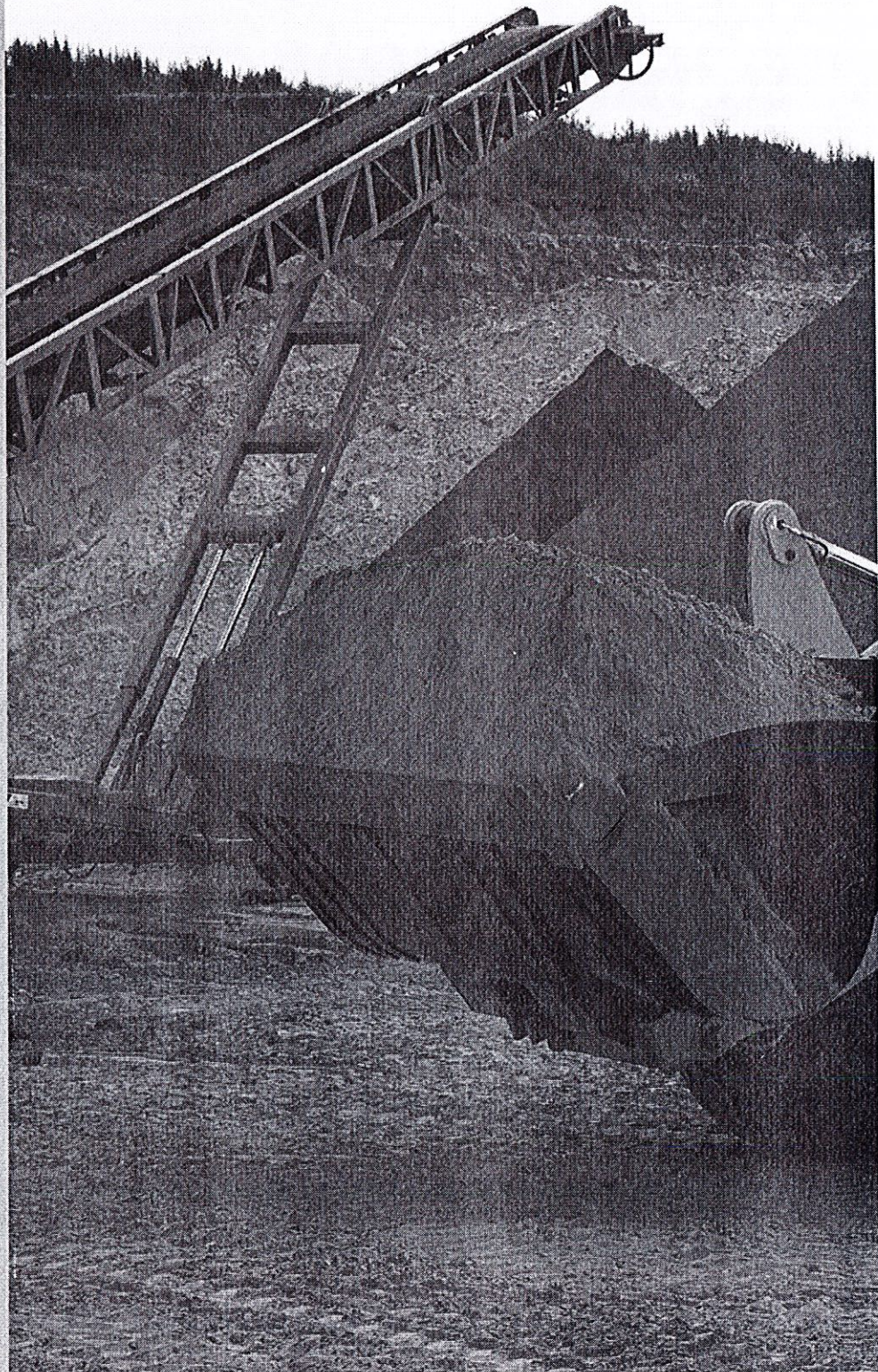

Environmental and customer friendly –
up to 95% recyclable content by weight



The Cat 926M, 930M and 938M Small Wheel Loaders set the standard for productivity, fuel efficiency and operator comfort. The improved optimized Z-bar loader linkage delivers the quick loading performance of a traditional Z-bar with the parallelism and load handling capability of a tool carrier. A high torque, low speed C7.1 ACERT engine works in concert with an intelligent hystat power train to deliver fuel efficiency as standard. Meets Tier 4 Final/Stage IV emission standards with an environmentally friendly, Clean Emission Module designed to manage itself so you can concentrate on your work. Experience the new industry benchmark.

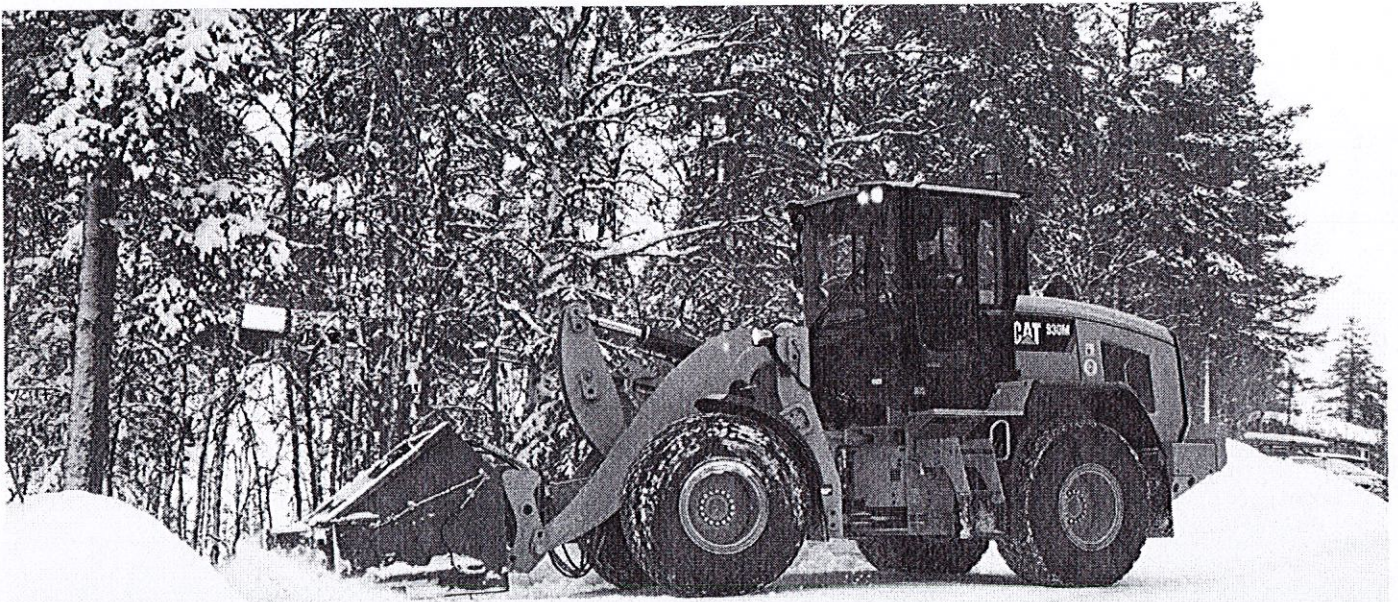

Efficiently Powerful

Experience hybrid-like fuel efficiency with more power when you need it.

Intelligent Power Management

The Caterpillar exclusive Intelligent Power Management system has been further enhanced to monitor operator input and power availability to keep the machine working at peak efficiency and provide the operator with greater customization to suit their application.

Power on Demand

A choice of Power Modes allows you to choose between maximum fuel efficiency or boosted power along with hydraulic speed.



Standard Power Mode

- Saves up to 10% fuel compared to K Series Cat loader.
- Delivers equal performance compared to K Series Cat Loader.
- Reduces cab sound levels down to a whisper quiet 64 dB(A) typical.
- Biggest gains seen during load and carry, snow removal and roading applications.

Performance Power Mode

- Enabled at the push of a button (HP+).
- Boosts engine power by up to 10% and engine speed by over 12%.
- Increases hydraulic cycle times and productivity.

Six Cylinders of Efficient Power

The Cat C7.1 ACERT engine provides cleaner, quieter operation while delivering superior performance and durability through a high torque, low speed design. The engine meets Tier 4 Final and Stage IV emission standards with a Clean Emissions Module that is designed to manage itself so you can concentrate on your work.

- **No downtime for regeneration** with a passive low temperature system that keeps you on the job.
- **Fit for Life Diesel Particulate Filter (DPF)** that is designed to exceed the engine overhaul life.
- **Extended fluid fill intervals** with minimal use of Diesel Exhaust Fluid (DEF) also referred to as Adblue™ with up to four fuel tank fills per DEF fill.
- **Configurable auto idle shut down** based on time and ambient temperature to further reduce fuel burn and keep operating costs low.

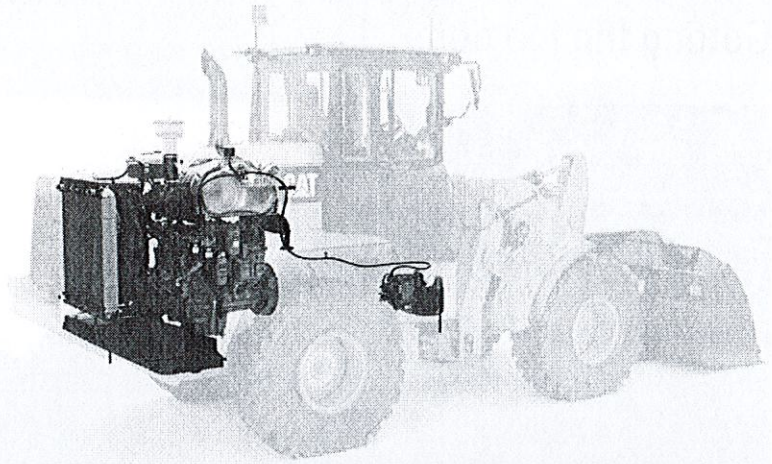

Power to the Ground

Lock up and go with fully locking front differential axles that can be engaged on the move at full torque with the pull of a trigger on the seat mounted joystick. Maximize your traction with optional Limited Slip Differential on the rear axle to keep you climbing.

Independent service brakes on front and rear axles provide robust stopping performance while a push button electronic park brake allows you to safely secure the machine with ease.

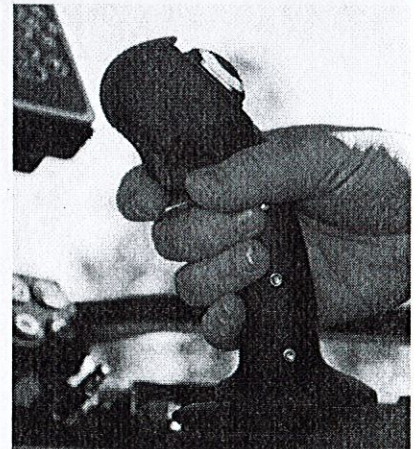

Work Made Easy

Getting the job done.

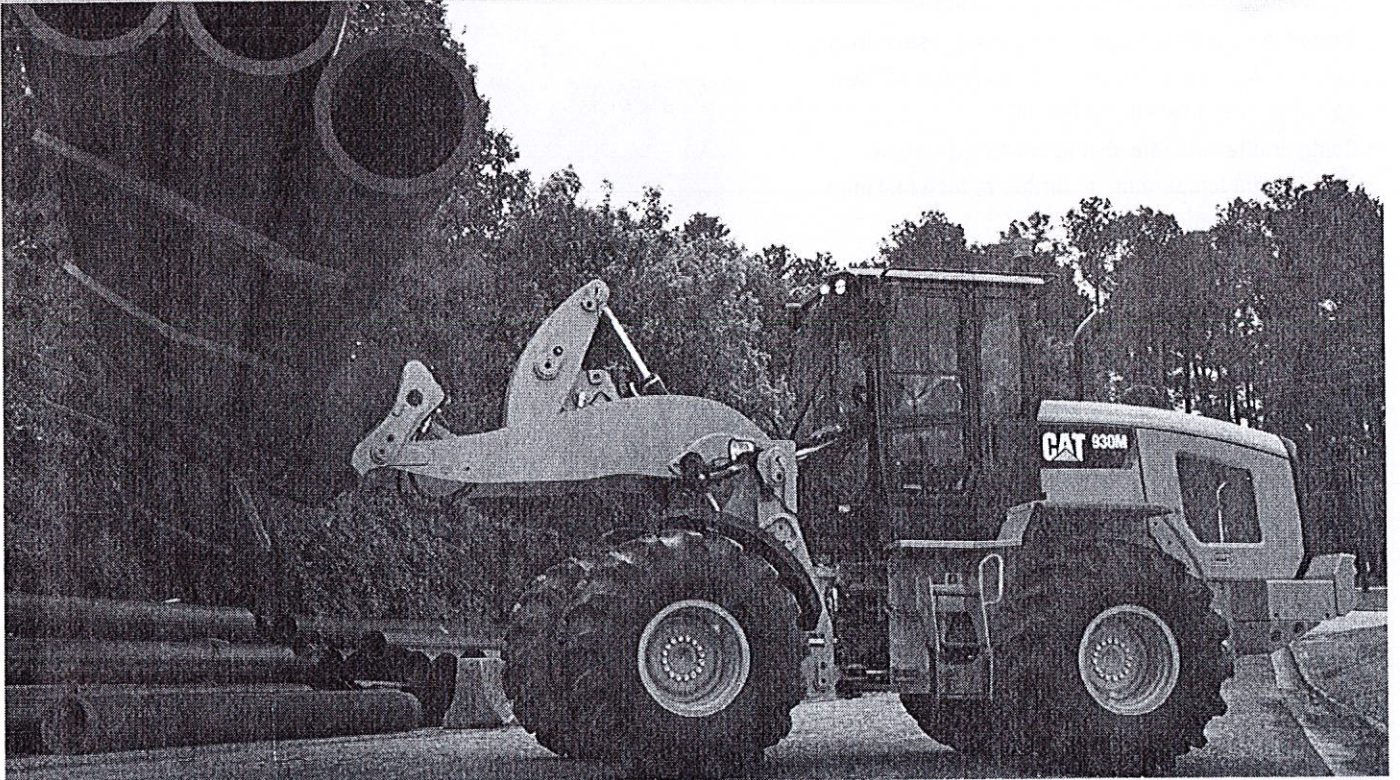

Optimized Z-bar Linkage

The Caterpillar patented optimized Z-bar linkage combines the digging efficiency of a traditional Z-bar with integrated tool carrier capabilities for great performance and versatility.

- **Perfect Parallelism** functionality available in Fork Mode gives truly predictable performance while high tilt forces throughout the working range help you safely and confidently handle loads with precise control.
- **Visibility** to bucket corners and fork tips at ground level remain excellent while sight lines at maximum lift are improved with a Generation II lift arm design.
- **Lift higher and reach further** with optional High Lift linkage available on all three models.

Quick Loading Performance Series Buckets

Performance Series Buckets deliver up to 10% higher fill factors and better material retention for significant productivity and fuel efficiency improvements. The buckets feature a longer floor to take a bigger bite of the pile, an open throat to heap higher and curved side bars to help with material retention. This optimized shape is echoed across the General Purpose, Light Material and High Dump bucket families.

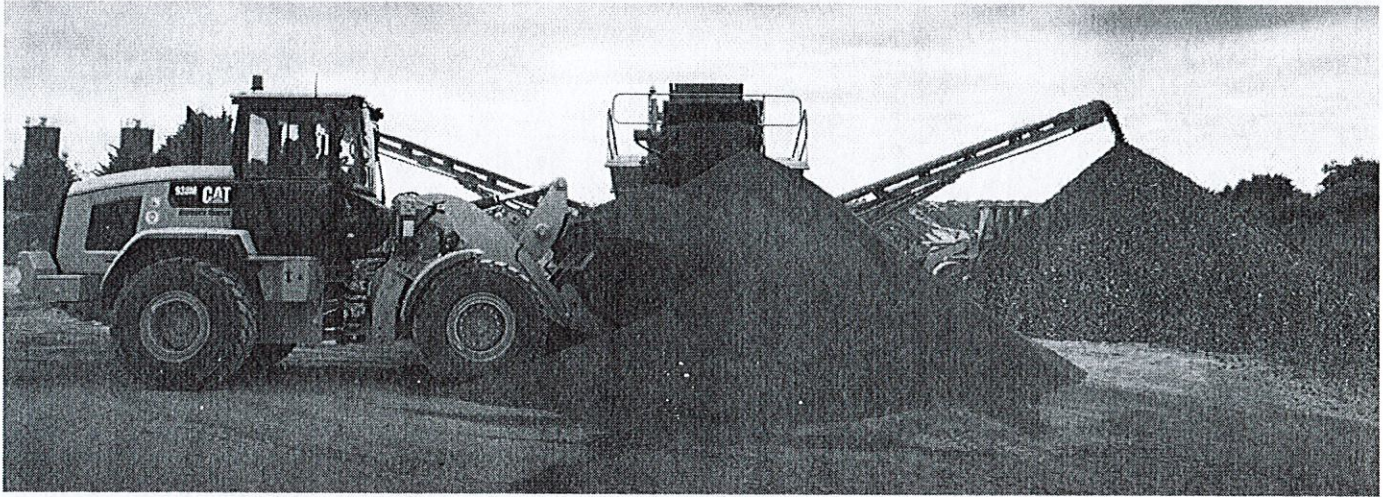

Smooth and Predictable Multi-Function Performance

M Series machines feature an electro-hydraulic control system that is governed by the Intelligent Power Management system for peak efficiency. The load-sensing, variable flow system senses work demand and adjusts flow and pressure to match the operators request.

- **Multi-Function without compromise** through dedicated hydraulic systems featuring one pump for the Intelligent Hydrostatic drive, a 2nd pump for the implements, and a 3rd pump for the steering system. Drive, Lift and Steer simultaneously with smooth predictable control. The M Series simply does what you ask it to.
- **Programmable in-cab kick-outs** are easy to set on the go for tilt, lower and lift. This feature is ideal for applications where the work cycle is repeatable allowing you to quickly return to programmed set points such as ground and level.
- **Fine tune hydro-mechanical performance** with fully adjustable 3rd and 4th function flow through the secondary display (when equipped) for a perfect marriage between machine and work tool.

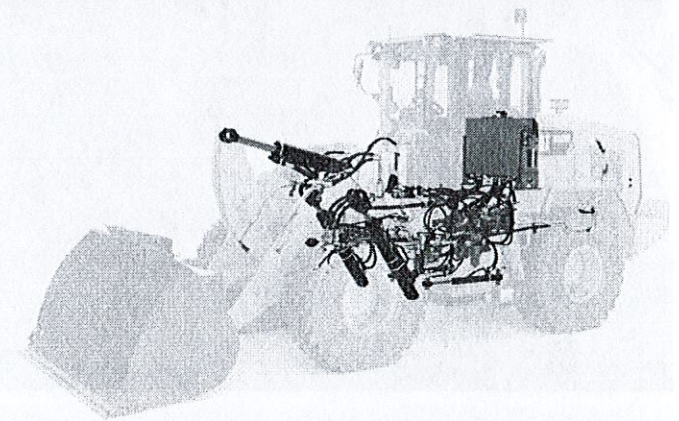

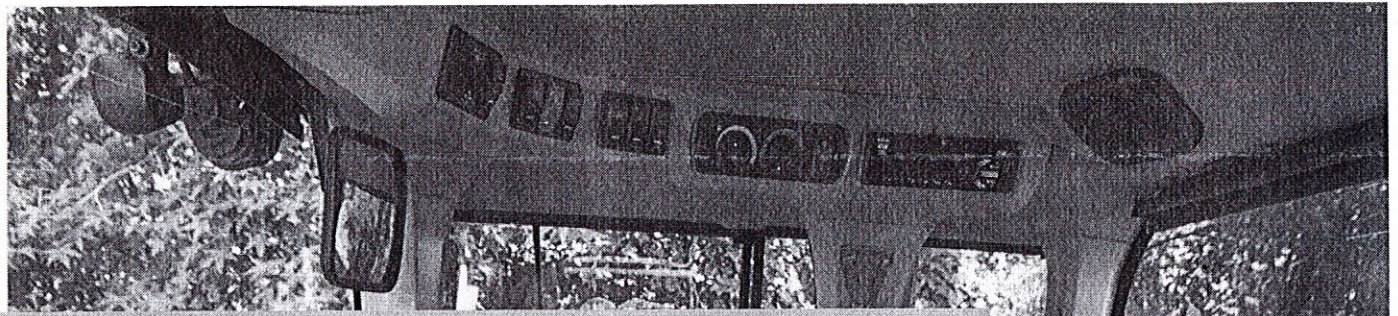

Enjoy All Day Comfort

Best seat on your job site.



Have a Seat and Experience:

- **Seat-mounted controls** featuring a low effort joystick for lift and tilt functions along with integrated Forward/Neutral/Reverse switch, differential lock trigger and optional third and fourth auxiliary functions.
- **Superior all around visibility** with single piece front windshield, new parabolic external mirrors, redesigned Generation II linkage and clean hydraulic lines routing.
- **Automatic climate control** with heated rear glass and external mirrors for a quick defrost.
- **Fully adjustable controls** including steering column, joystick and seat suspension.
- **Information at a glance** with large primary LCD display and optional secondary display.
- **An extra eye on the job site** with optional rearview camera and integrated object detection.
- **A heated and cooled seat option** for added comfort in a wide range of climates.

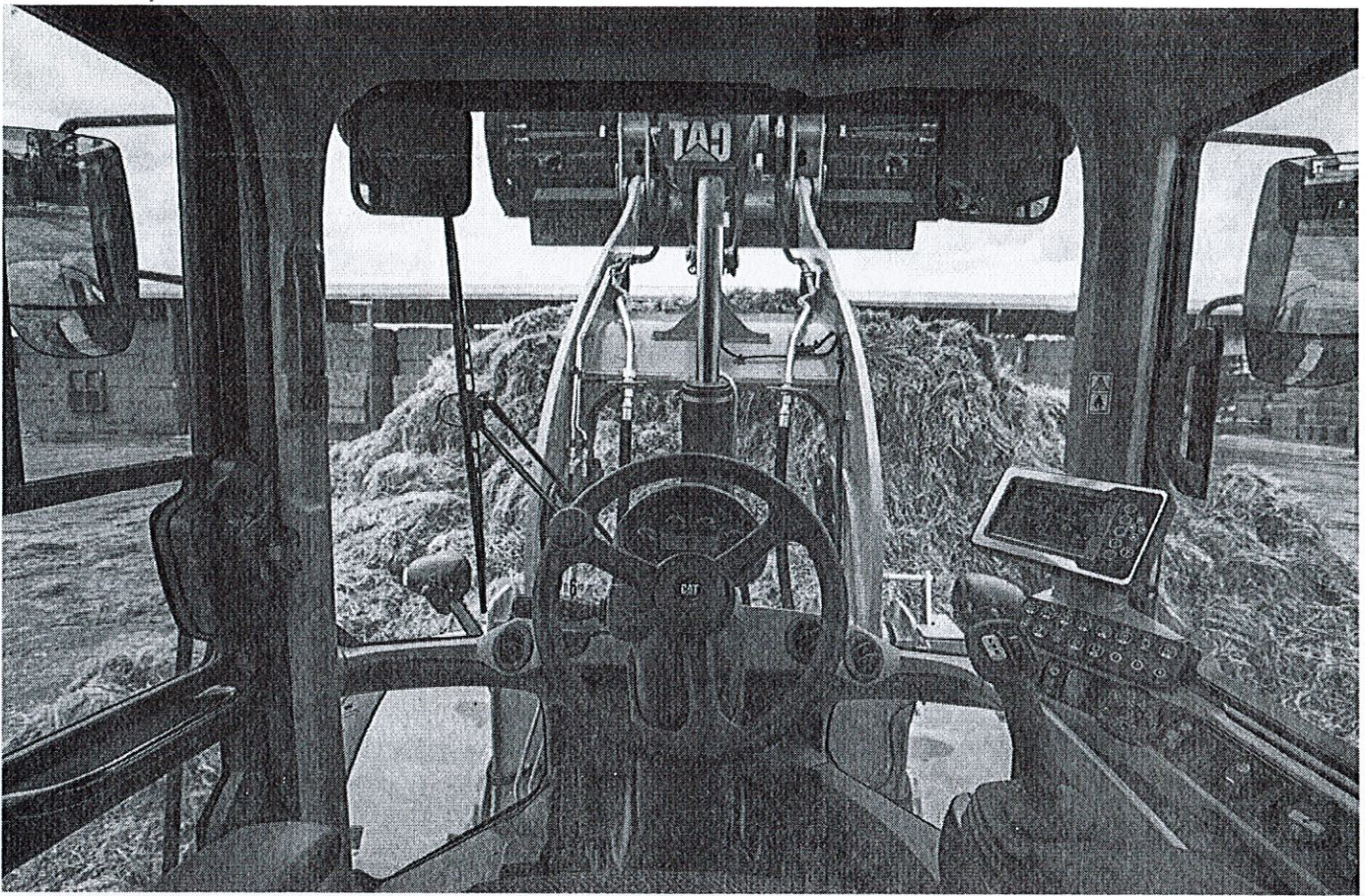

Enjoy coming to work with:

- **A spacious, safe, quiet operator environment** featuring ergonomic controls, seat belt notification and optional bluetooth radio with integrated microphone plus an MP3 port.
- **Easy access to vital machine parameters** with the optional* secondary display that works in conjunction with the standard soft touch panel to allow real time adjustments to machine features and an integrated help button with over 25 languages.
- **Comfortable soft stops at cylinder end stroke** conditions and programmed kick-out points with Caterpillar's exclusive electro-hydraulic cylinder snubbing.
- **An even smoother ride** with optional Ride Control when working unloaded and loaded with excellent material retention.
- **Early starts and late finishes** are made easier with optional LED lighting package that includes engine compartment lighting to illuminate the way for checking oil, and coolant level along with re-fueling the machine in dark conditions.

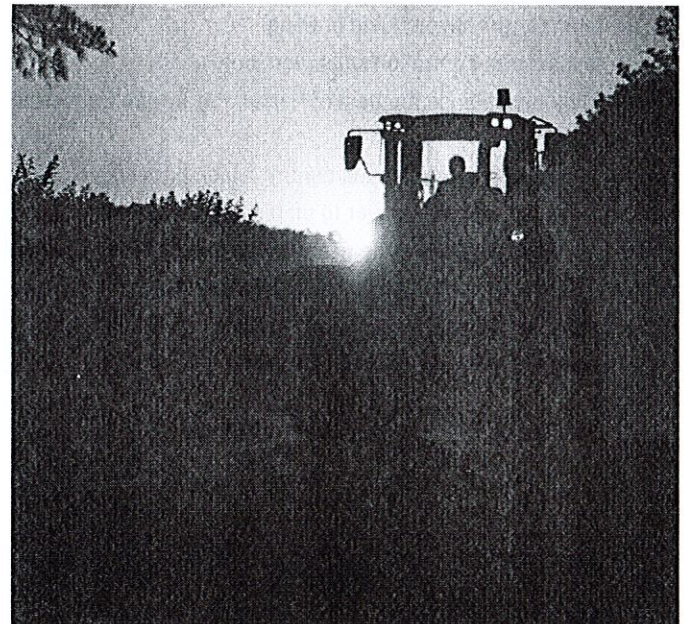
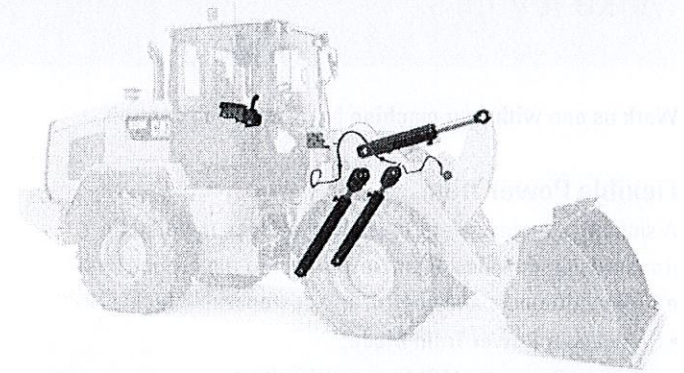

*Standard in Europe

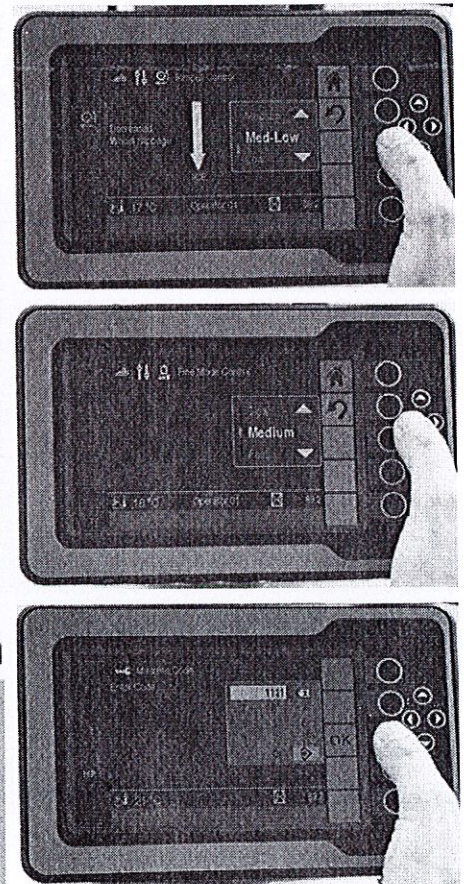
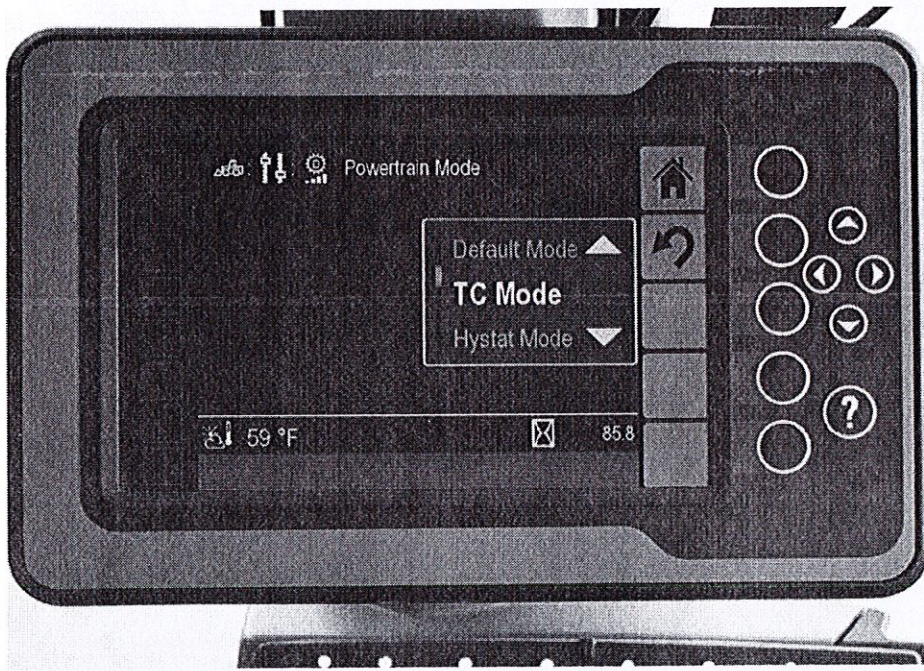

Customize Your Experience

Make it yours.

Work as one with your machine by customizing controls.

Flexible Power Train

A smooth, step-less electronically controlled hydrostatic transmission provides adjustable power to the ground with excellent groundspeed control and customizable feel.

- **Select your Power Train Mode:**
 - Torque Converter (TC) for smooth rollout.
 - Hystat for aggressive engine braking.
 - Ice to maximize control on snow and ice.
 - Default which blends the best of Hystat and Torque Converter characteristic.
- **Reduce tire wear** using Rimpull control which enables you to match available tractive power to underfoot conditions.
- **Fine tune ground speed** when using work tools such as brooms, snow blowers and brush cutters with Creeper Control.
- **Set Directional Shift Response**, soft and smooth for material handling applications or sharp for aggressive operation.

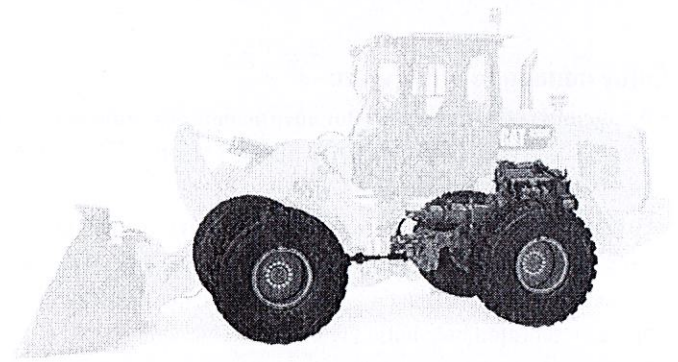

Adjustable Electro-Hydraulic Controls

Easily customize hydraulic performance to meet your needs.

- **Optimize hydraulic modulation** with Fine Mode control when working with forks, material handling arms, and large tools.
- **Quicker hydraulic response** for fine grading at speed and agriculture applications through Lift and Tilt response settings.
- **Fully adjustable ride control** activation speed along with 3rd and 4th function auxiliary flows.

Operator Profiles and Coded Start

- The M Series Wheel Loaders will remember you and your personal settings with unique operator codes to make this machine truly yours and keep it secure.

Configured for Success

Ready to work for you.

The Way You Want It

A complete range of optional equipment and work tools give you the versatility to configure an M Series wheel loader to be successful in your business. Get with your Cat dealer to configure yours.

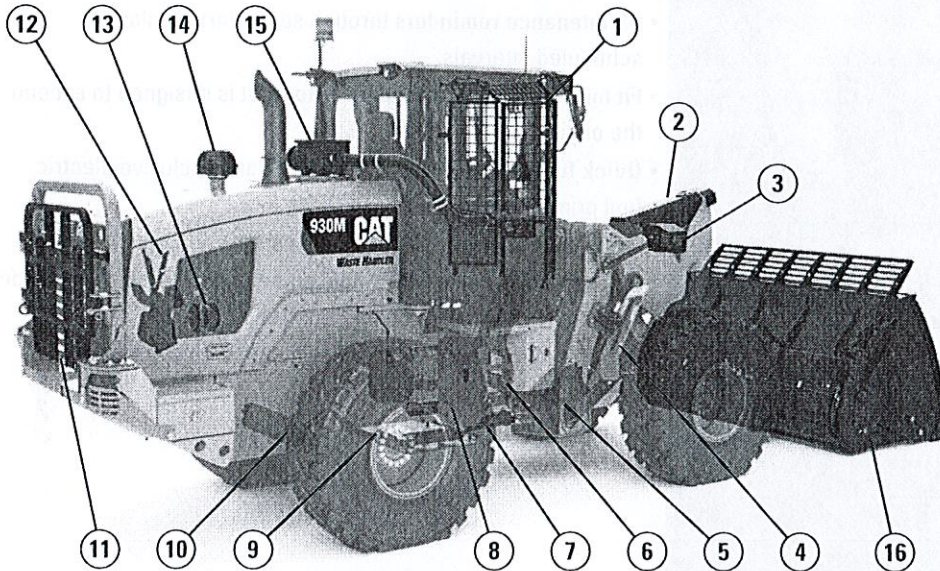

Guards:

- 1) Windshield
- 2) Tilt cylinder
- 3) Lights
- 4) Fender deflectors
- 5) Drive shaft
- 6) Hitch
- 7) Steering cylinders
- 8) Side power train
- 9) Lower power train
- 10) Crank case
- 11) Rear radiator (930M and 938M only)

Debris Packages:

- 12) Reversing fan
- 13) Sealed alternator
- 14) Turbine precleaner
- 15) RESPA precleaner

Work Tools:

- 16) Full range of attachments

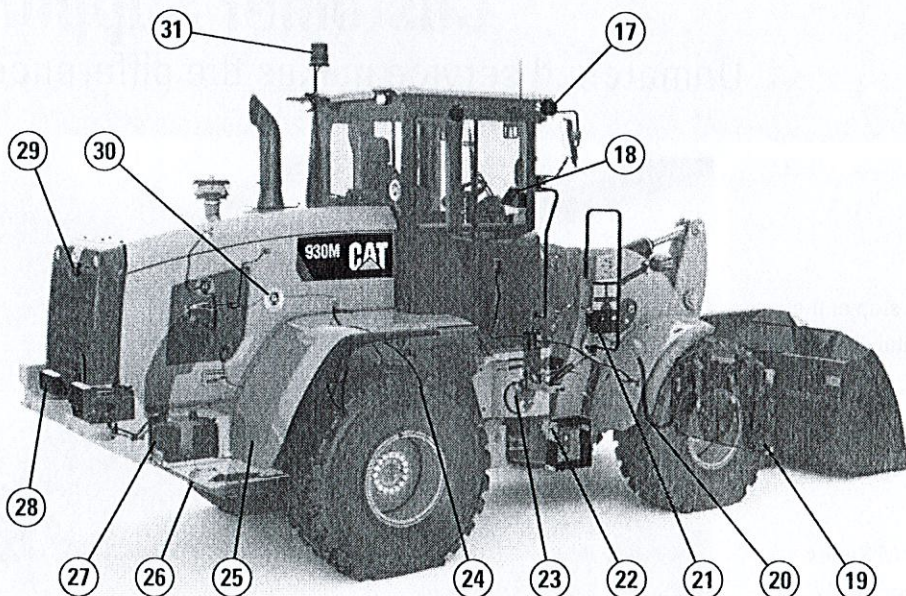

Other Options:

- 17) LED auxiliary lights
- 18) Secondary display*
- 19) Coupler: Fusion and ISO
- 20) Auxiliary hydraulics: 3rd and 4th
- 21) Autolube
- 22) Windshield washing platform
- 23) Ride control
- 24) Elevated breathers: axles and gear box
- 25) Fenders: extended and full coverage
- 26) Counterweights: heavy and Log/Agg
- 27) Cold start package
- 28) Rear object detection
- 29) Rearview camera*
- 30) Blue Angel certification
- 31) Beacon

*Standard equipment in Europe

Service

Schedule your downtime to maximize your up time.

Get up and running quickly with ground level, daily service access and optional engine compartment lighting. Three large service doors can be opened and closed in any order to give full access to filters and service points. Extended service intervals on hydraulic and power train filters reduce service time and maximize uptime. Additional service features include:

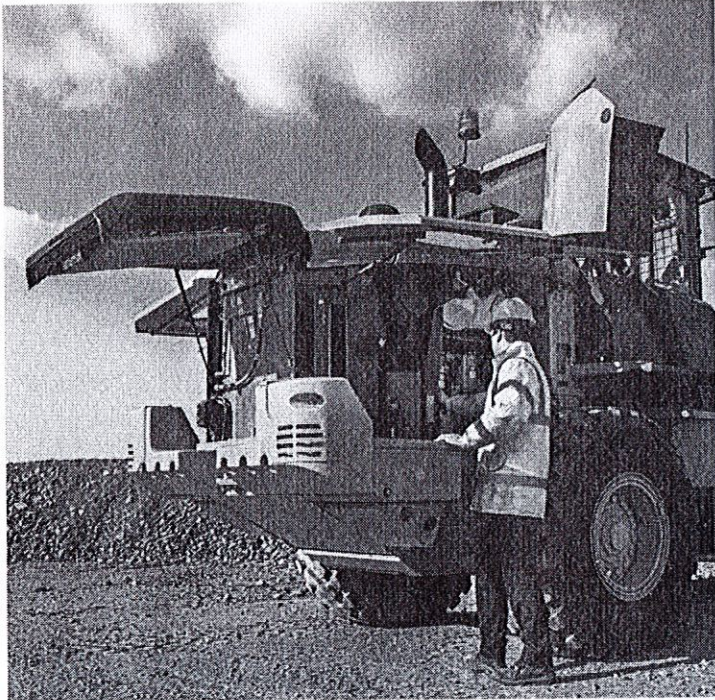

- **Product Link™ PRO standard** with three year subscription to VisionLink®.
- **Maintenance reminders** through secondary display at scheduled intervals.
- **Fit for Life Diesel Particulate Filter** that is designed to exceed the engine overhaul life.
- **Quick fuel filter service** with Caterpillar's exclusive electric fuel priming pump.
- **Jump start studs** as standard equipment.
- **Extended cleanouts** with single plane cooling system and wide spaced 6 fins per inch coolers as standard.
- **Integrated Autolube** (optional) with adjustable greasing frequency.

Customer Support

Unmatched service makes the difference.

Renowned Cat Dealer Support

Rely on your Cat dealer to help you every step of the way with new or used machine sales, rental or rebuild options to meet your business needs.

Maximize your machine uptime with unsurpassed worldwide parts availability, trained technicians and customer support agreements.

Let us earn your business. Experience an M Series Small Wheel Loader and join the Caterpillar family.



926M, 930M, 938M Wheel Loader Specifications

Engine

Cat C7.1 ACERT Power Mode	926M				930M				938M			
	Performance (HP+)		Standard		Performance (HP+)		Standard		Performance (HP+)		Standard	
	Range 1-4		Range 1-3*		Range 1-4		Range 1-3*		Range 1-4		Range 1-3*	
Maximum Rated Gross Power	kW hp		kW hp		kW hp		kW hp		kW hp		kW hp	
Maximum Engine Speed	1,800 rpm		1,600 rpm		1,800 rpm		1,600 rpm		1,800 rpm		1,600 rpm	
ISO 14396	114	153	109	146	122	164	119	160	140	188	129	173
ISO 14396 (DIN)	114	155	109	148	122	166	119	162	140	190	129	175
Rated Net Power	1,800 rpm		1,600 rpm		1,800 rpm		1,600 rpm		1,800 rpm		1,600 rpm	
SAE J1349 at Minimum Fan Speed	110	148	105	141	117	157	115	154	136	182	125	168
ISO 9249 (1977)/EEC 80/1269 at Minimum Fan Speed	111	149	106	142	119	160	116	156	137	184	126	169
ISO 9249 (DIN) at Minimum Fan Speed	111	151	106	144	119	162	116	158	137	186	126	171
Maximum Gross Torque	N-m lbf-ft		N-m lbf-ft		N-m lbf-ft		N-m lbf-ft		N-m lbf-ft		N-m lbf-ft	
ISO 14396	721	531	721	531	804	592	804	592	879	648	879	648
Maximum Net Torque	SAE J1349		ISO 9249 (1977)/EEC 80/1269		SAE J1349		ISO 9249 (1977)/EEC 80/1269		SAE J1349		ISO 9249 (1977)/EEC 80/1269	
	694	511	694	511	768	566	768	566	843	621	843	621
	702	517	702	517	776	572	776	572	852	628	852	628
Displacement	427 in ³		7.01 L		427 in ³		7.01 L		427 in ³		7.01 L	
Bore	4 in		105 mm		4 in		105 mm		4 in		105 mm	
Stroke	5 in		135 mm		5 in		135 mm		5 in		135 mm	

- * Range 4 power and torque is equal to Performance Mode with Caterpillar Power by Range technology.
- Net power ratings are tested at the reference conditions for the specified standard and denote power available at the flywheel when the engine is equipped with alternator, air cleaner, emission components and fan at specified speed.
- No derating required up to 3000 m (10,000 ft) altitude. Auto derate protects hydraulic and transmission systems.
- The Cat C7.1 ACERT engine meets Tier 4 Final/Stage IV off-highway emission standards.

Engine Torque

926M

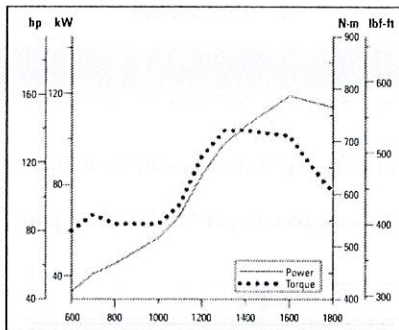

930M

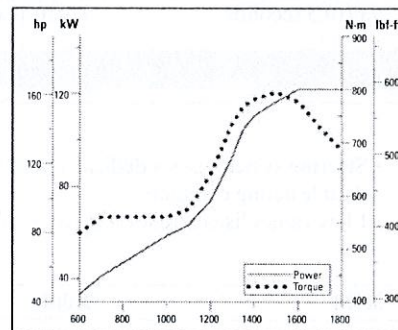

938M

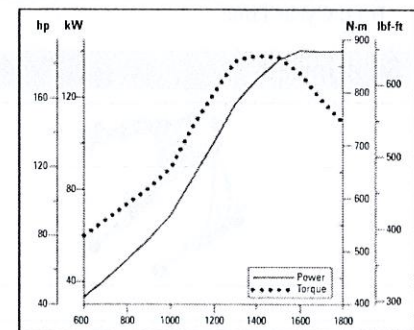

Cab

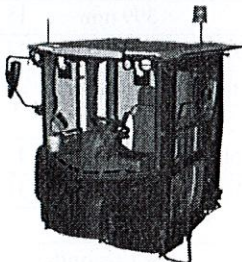

- ROPS: SAE J1040 MAY94, ISO 3471-1994.
- FOPS: SAE J/ISO 3449 APR98, Level II, ISO 3449 1992 Level II.
- The declared dynamic operator around pressures levels per ISO 6396:2008* while running in Performance Power Mode:
 - Standard cab: 68 ±3 dB(A) and Deluxe cab: 66 ±2 dB(A)

* The measurements were conducted with the cab doors and windows closed and at 70% of maximum engine cooling fan speed. The sound level may vary at different engine cooling fan speeds.

926M, 930M, 938M Wheel Loader Specifications

Loader Hydraulic System

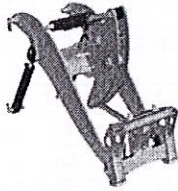

- Implement system uses a dedicated load sensing variable displacement pump with dual double acting lift cylinders and a single double acting tilt cylinder.
- Flow values listed are for a machine running in Performance Power Mode (1,800 rpm).

* 3rd and 4th function flow is fully adjustable from 20% to 100% of maximum flow through the secondary display when equipped.

	926M		930M		938M	
Maximum Flow – Implement Pump	150 L/min	40 gal/min	190 L/min	50 gal/min	190 L/min	50 gal/min
3rd Function Maximum Flow*	150 L/min	40 gal/min	190 L/min	50 gal/min	190 L/min	50 gal/min
4th Function Maximum Flow*	150 L/min	40 gal/min	160 L/min	42 gal/min	160 L/min	42 gal/min
Maximum Working Pressure – Implement Pump	26 000 kPa	3,771 psi	25 000 kPa	3,626 psi	28 000 kPa	4,061 psi
Relief Pressure – Tilt Cylinder	28 000 kPa	4,061 psi	28 000 kPa	4,061 psi	30 000 kPa	4,351 psi
3rd and 4th Function Maximum Working Pressure	26 000 kPa	3,771 psi	25 000 kPa	3,626 psi	28 000 kPa	4,061 psi
3rd and 4th Function Relief Pressure	28 000 kPa	4,061 psi	28 000 kPa	4,061 psi	30 000 kPa	4,351 psi
Lift Cylinder: Double Acting						
Bore Diameter	110 mm	4.3 in	120 mm	4.7 in	120 mm	4.7 in
Rod Diameter	60 mm	2.4 in	65 mm	2.6 in	65 mm	2.6 in
Stroke	728 mm	28.7 in	728 mm	28.7 in	789 mm	31.1 in
Tilt Cylinder: Double Acting						
Bore Diameter	130 mm	5.1 in	150 mm	5.9 in	150 mm	5.9 in
Rod Diameter	70 mm	2.8 in	90 mm	3.5 in	90 mm	3.5 in
Stroke	555 mm	21.9 in	555 mm	21.9 in	555 mm	21.9 in
Cycle Times: Performance (HP+) at 1,800 rpm/ Standard Power Mode at 1,600 rpm						
Raise (Ground Level to Maximum Lift)	5.5/6.2 seconds		5.1/5.7 seconds		5.5/6.2 seconds	
Dump (at Maximum Lift Height)	1.5/1.7 seconds		1.5/1.7 seconds		1.5/1.7 seconds	
Float Down (Maximum Lift to Ground Level)	2.6/2.6 seconds		2.7/2.7 seconds		2.7/2.7 seconds	
Total Cycle Time	9.6/10.5 seconds		9.3/10.1 seconds		9.7/10.6 seconds	

Steering

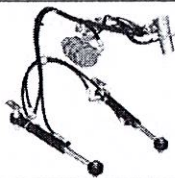

- Steering system uses a dedicated load sensing variable displacement pump with dual double acting cylinders.
- Flow values listed are for a machine running in Performance Power Mode (1,800 rpm).

	926M		930M		938M	
Steering Cylinder: Double Acting						
Bore Diameter	70 mm	2.8 in	70 mm	2.8 in	80 mm	3.1 in
Rod Diameter	40 mm	1.6 in	40 mm	1.6 in	50 mm	2 in
Stroke	438 mm	17.2 in	438 mm	17.2 in	399 mm	15.7 in
Maximum Flow – Steering Pump	130 L/min	34 gal/min	130 L/min	34 gal/min	130 L/min	34 gal/min
Maximum Working Pressure – Steering Pump	24 130 kPa	3,500 psi	24 130 kPa	3,500 psi	24 130 kPa	3,500 psi
Maximum Steering Torque						
0° (Straight Machine)	50 375 N·m	37,155 lbf-ft	50 375 N·m	37,155 lbf-ft	57 630 N·m	42,506 lbf-ft
40° (Full Turn)	37 620 N·m	27,747 lbf-ft	37 620 N·m	27,747 lbf-ft	42 570 N·m	31,398 lbf-ft
Steering Cycle Times (Full Left to Full Right)						
Minimum RPM: Pump Flow Limited	2.8 seconds		2.8 seconds		3.1 seconds	
Maximum RPM: 90 rpm Steering Wheel Speed	2.4 seconds		2.4 seconds		2.3 seconds	

926M, 930M, 938M Wheel Loader Specifications

Transmission

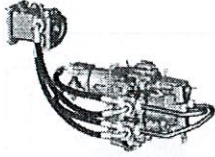

* Creeper control allows maximum speed range adjustability from 1 km/h (0.6 mph) to 13 km/h (8 mph) in Range 1 through the secondary display when equipped. Factory default is 7 km/h (4.4 mph).

	926M		930M		938M	
Forward and Reverse						
Range 1*	1-13 km/h	0.6-8 mph	1-13 km/h	0.6-8 mph	1-13 km/h	0.6-8 mph
Range 2	13 km/h	8 mph	13 km/h	8 mph	13 km/h	8 mph
Range 3	27 km/h	17 mph	27 km/h	17 mph	27 km/h	17 mph
Range 4	40 km/h	25 mph	40 km/h	25 mph	40 km/h	25 mph

Service Refill Capacities

	926M		930M		938M	
Fuel Tank	195 L	51.5 gal	195 L	51.5 gal	195 L	51.5 gal
Diesel Exhaust Fluid (DEF) Tank	19 L	5.0 gal	19 L	5.0 gal	19 L	5.0 gal
Cooling System	30 L	7.9 gal	30 L	7.9 gal	32 L	8.5 gal
Engine Crankcase	20 L	5.3 gal	20 L	5.3 gal	20 L	5.3 gal
Transmission (Gear Box)	8.5 L	2.2 gal	8.5 L	2.2 gal	11 L	2.9 gal
Front Axles	21 L	5.5 gal	26 L	6.9 gal	35 L	9.2 gal
Rear Axles	21 L	5.5 gal	25 L	6.6 gal	35 L	9.2 gal
Hydraulic System (Including Tank)	160 L	42.3 gal	165 L	43.6 gal	170 L	44.9 gal
Hydraulic Tank	90 L	23.8 gal	90 L	23.8 gal	90 L	23.8 gal

Power Train

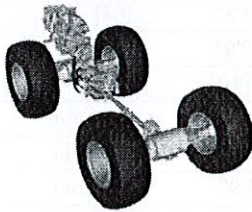

• Power train is governed by the Caterpillar exclusive Intelligent Power Management system to deliver peak performance and efficiency.

* Differential front locking axle can be engaged on the go at full torque to 10 km/h (6.2 mph) on the 926M/930M and up to 20 km/h (12.4 mph) on the 938M.

	926M	930M	938M
Front Axle	Fixed	Fixed	Fixed
Traction Aid (standard)	Locking differential	Locking differential	Locking differential
Rear Axle	Oscillating	Oscillating	Oscillating
Oscillation Angle by Tire Size			
17.5 R25	± 13.5 degrees	—	—
20.5 R25, 550/65, 600/65, 650/65	± 10.5 degrees	± 10.5 degrees	± 10.5 degrees
23.5 R25	—	—	± 7 degrees
Flexports, 750/65, 620/65, Skidder	± 7 degrees	± 7 degrees	± 7 degrees
Traction Aid (optional)	Limited slip differential	Limited slip differential	Limited slip differential
Brakes			
Service	Inboard wet disc	Inboard wet disc	Outboard wet disc
Park	Spring applied hydraulically released	Spring applied hydraulically released	Spring applied hydraulically released

926M, 930M, 938M Wheel Loader Specifications

Dimensions with Bucket

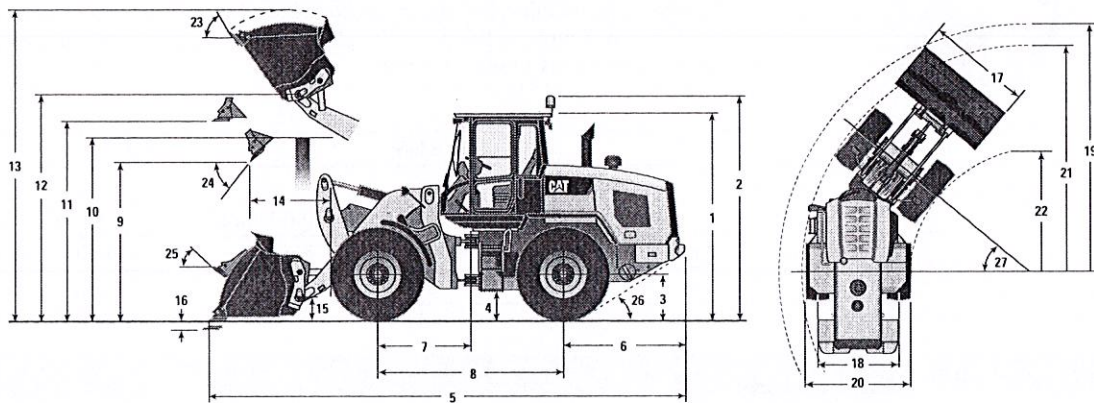

	Standard Lift					
	926M		930M		938M	
* Vary with bucket.						
** Vary with tire.						
** 1 Height: Ground to Cab	3340 mm	10'11"	3340 mm	10'11"	3340 mm	10'11"
** 2 Height: Ground to Beacon	3707 mm	12'1"	3707 mm	12'1"	3707 mm	12'1"
** 3 Height: Ground Axle Center	685 mm	2'2"	685 mm	2'2"	685 mm	2'2"
** 4 Height: Ground Clearance	397 mm	1'3"	397 mm	1'3"	386 mm	1'3"
* 5 Length: Overall	7451 mm	24'5"	7530 mm	24'8"	7656 mm	25'1"
6 Length: Rear Axle to Bumper	1986 mm	6'6"	1993 mm	6'6"	1968 mm	6'5"
7 Length: Hitch to Front Axle	1500 mm	4'11"	1500 mm	4'11"	1525 mm	5'0"
8 Length: Wheel Base	3000 mm	9'10"	3000 mm	9'10"	3050 mm	10'0"
* 9 Clearance: Bucket at 45°	2885 mm	9'5"	2828 mm	9'3"	2834 mm	9'3"
** 10 Clearance: Load over Height	3330 mm	10'11"	3331 mm	10'11"	3354 mm	11'0"
** 11 Clearance: Level Bucket	3580 mm	11'8"	3580 mm	11'8"	3641 mm	11'11"
** 12 Height: Bucket Pin	3907 mm	12'9"	3907 mm	12'9"	3969 mm	13'0"
** 13 Height: Overall	5076 mm	16'7"	5147 mm	16'10"	5273 mm	17'3"
* 14 Reach: Bucket at 45°	1024 mm	3'4"	1064 mm	3'5"	1146 mm	3'9"
15 Carry Height: Bucket Pin	460 mm	1'6"	460 mm	1'6"	473 mm	1'6"
** 16 Dig Depth	100 mm	3.9"	100 mm	3.9"	101 mm	3.9"
17 Width: Bucket	2550 mm	8'4"	2550 mm	8'4"	2750 mm	9'0"
18 Width: Tread Center	1930 mm	6'3"	1930 mm	6'3"	2083 mm	6'10"
19 Turning Radius: Over Bucket	5924 mm	19'5"	5946 mm	19'6"	6134 mm	20'1"
20 Width: Over Tires	2540 mm	8'4"	2540 mm	8'4"	2693 mm	8'10"
21 Turning Radius: Outside of Tires	5402 mm	17'8"	5402 mm	17'8"	5546 mm	18'2"
22 Turning Radius: Inside of Tires	2851 mm	9'4"	2851 mm	9'4"	2843 mm	9'3"
23 Rack Angle at Full Lift	54°		54°		54°	
24 Dump Angle at Full Lift	50°		49°		49°	
25 Rack Angle at Carry	45°		45°		46°	
26 Departure Angle	33°		33°		33°	
27 Articulation Angle	40°		40°		40°	

Unless otherwise noted, all Standard Lift dimensions and specifications listed are for a machine configured with the following:

Optional Equipment	Full Fluids, 80 kg (176 lb) Operator, Secondary Steering, Ride Control, Crankcase, Power Train and Driveshaft Guards, Bucket with Bolt-on Cutting Edge					
Tires – Michelin	20.5R25 (L-3) XHA2		20.5R25 (L-3) XHA2		20.5R25 (L-3) XHA2	
Pressure in Front Tires	4.14 bar	60 psi	4.14 bar	60 psi	4.48 bar	65 psi
Pressure in Rear Tires	2.76 bar	40 psi	2.76 bar	40 psi	2.76 bar	40 psi
Counterweight Group	Heavy		Heavy		Heavy	

926M, 930M, 938M Wheel Loader Specifications

Dimensions with Bucket

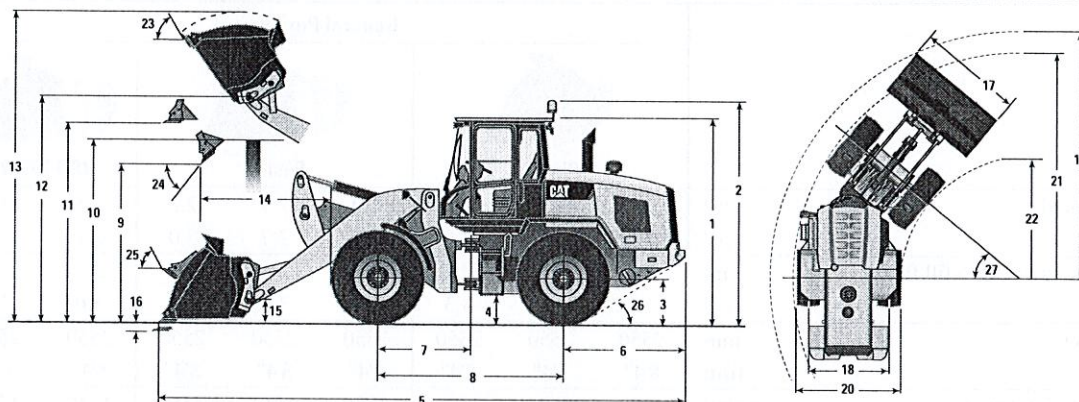

*Vary with bucket.

**Vary with tire.

High Lift



	926M		930M		938M	
** 1 Height: Ground to Cab	3340 mm	10'11"	3340 mm	10'11"	3340 mm	10'11"
** 2 Height: Ground to Beacon	3707 mm	12'1"	3707 mm	12'1"	3707 mm	12'1"
** 3 Height: Ground Axle Center	685 mm	2'2"	685 mm	2'2"	685 mm	2'2"
** 4 Height: Ground Clearance	397 mm	1'3"	397 mm	1'3"	386 mm	1'3"
* 5 Length: Overall	8093 mm	26'6"	8324 mm	27'3"	8397 mm	27'6"
6 Length: Rear Axle to Bumper	1986 mm	6'6"	1993 mm	6'6"	1968 mm	6'5"
7 Length: Hitch to Front Axle	1500 mm	4'11"	1500 mm	4'11"	1525 mm	5'0"
8 Length: Wheel Base	3000 mm	9'10"	3000 mm	9'10"	3050 mm	10'0"
* 9 Clearance: Bucket at 45°	3378 mm	11'0"	3421 mm	11'2"	3415 mm	11'2"
** 10 Clearance: Load over Height	3550 mm	11'7"	3540 mm	11'7"	3561 mm	11'8"
** 11 Clearance: Level Bucket	4073 mm	13'4"	4173 mm	13'8"	4222 mm	13'10"
** 12 Height: Bucket Pin	4400 mm	14'5"	4500 mm	14'9"	4550 mm	14'11"
** 13 Height: Overall	5569 mm	18'3"	5740 mm	18'9"	5853 mm	19'2"
* 14 Reach: Bucket at 45°	1261 mm	4'1"	1385 mm	4'6"	1413 mm	4'7"
15 Carry Height: Bucket Pin	644 mm	2'1"	684 mm	2'2"	682 mm	2'2"
** 16 Dig Depth	135 mm	5.3"	135 mm	5.3"	135 mm	5.3"
17 Width: Bucket	2550 mm	8'4"	2550 mm	8'4"	2750 mm	9'0"
18 Width: Tread Center	1930 mm	6'3"	1930 mm	6'3"	2083 mm	6'10"
19 Turning Radius: Over Bucket	6234 mm	20'5"	6328 mm	20'9"	6490 mm	21'3"
20 Width: Over Tires	2540 mm	8'4"	2540 mm	8'4"	2693 mm	8'10"
21 Turning Radius: Outside of Tires	5402 mm	17'8"	5402 mm	17'8"	5546 mm	18'2"
22 Turning Radius: Inside of Tires	2851 mm	9'4"	2851 mm	9'4"	2843 mm	9'3"
23 Rack Angle at Full Lift	51°		53°		53°	
24 Dump Angle at Full Lift	49°		48°		47°	
25 Rack Angle at Carry	49°		50°		50°	
26 Departure Angle	33°		33°		33°	
27 Articulation Angle	40°		40°		40°	

Unless otherwise noted, all High Lift dimensions and specifications listed are for a machine configured with the following:

Optional Equipment	Full Fluids, 80 kg (176 lb) Operator, Secondary Steering, Ride Control, Crankcase, Power Train and Driveshaft Guards, Bucket with Bolt-on Cutting Edge					
Tires – Michelin	20.5R25 (L-3) XHA2	20.5R25 (L-3) XHA2	20.5R25 (L-3) XHA2	20.5R25 (L-3) XHA2	20.5R25 (L-3) XHA2	20.5R25 (L-3) XHA2
Pressure in Front Tires	4.14 bar	60 psi	4.14 bar	60 psi	4.48 bar	65 psi
Pressure in Rear Tires	2.76 bar	40 psi	2.76 bar	40 psi	2.76 bar	40 psi
Counterweight Group	Heavy	Heavy	Heavy	Heavy	Standard	Standard

Bucket Specifications

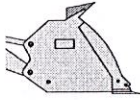
926M Operating Specifications with Buckets

		General Purpose									High Lift
		 Pin On			 Fusion			 ISO 23727			
Capacity – rated	m ³	1.9	2.1	2.3	1.9	2.1	2.3	2.1	2.3	–	
	yd ³	2.5	2.7	3.0	2.5	2.7	3.0	2.7	3.0	–	
Capacity – rated at 110% fill factor	m ³	2.1	2.3	2.5	2.1	2.3	2.5	2.3	2.5	–	
	yd ³	2.7	3.0	3.3	2.7	3.0	3.3	3.0	3.3	–	
17 Width: bucket	mm	2550	2550	2550	2550	2550	2550	2550	2550	–	
	ft/in	8'4"	8'4"	8'4"	8'4"	8'4"	8'4"	8'4"	8'4"	–	
Nominal material density, 110% fill factor	kg/m ³	1889	1696	1529	1800	1612	1457	1530	1383	–	
	lb/yd ³	3,223	2,879	2,584	3,072	2,736	2,462	2,598	2,338	–	
9 Clearance: full lift, 45° dump	mm	2912	2855	2807	2885	2828	2779	2727	2677	+493	
	ft/in	9'6"	9'4"	9'2"	9'5"	9'3"	9'1"	8'11"	8'9"	+1'7"	
14 Reach: full lift, 45° dump	mm	992	1033	1070	1024	1064	1102	1190	1227	+237	
	ft/in	3'3"	3'4"	3'6"	3'4"	3'5"	3'7"	3'10"	4'0"	+9"	
Reach: 2130 mm (7'0") clearance, 45° dump	mm	1547	1560	1573	1566	1578	1590	1649	1657	+572	
	ft/in	5'0"	5'1"	5'1"	5'1"	5'2"	5'2"	5'4"	5'5"	+1'10"	
Reach: level arm, level bucket	mm	2278	2350	2413	2320	2392	2455	2553	2616	+523	
	ft/in	7'5"	7'8"	7'11"	7'7"	7'10"	8'0"	8'4"	8'6"	+1'8"	
16 Dig depth	mm	100	100	100	100	100	100	94	94	+35	
	in	3.9"	3.9"	3.9"	3.9"	3.9"	3.9"	3.7"	3.7"	+1.4"	
5 Length: overall	mm	7409	7481	7544	7451	7523	7586	7679	7742	+642	
	ft/in	24'3"	24'6"	24'9"	24'5"	24'8"	24'10"	25'2"	25'4"	+2'1"	
13 Height: overall	mm	5052	5122	5180	5076	5147	5205	5255	5313	+493	
	ft/in	16'6"	16'9"	16'11"	16'7"	16'10"	17'0"	17'2"	17'5"	+1'7"	
19 Turning radius: over bucket	mm	5912	5933	5951	5924	5946	5964	5975	5995	+311	
	ft/in	19'4"	19'5"	19'6"	19'5"	19'6"	19'6"	19'7"	19'8"	+1'0"	
Tipping load – straight, ISO 14397-1*	kg	9179	9115	9008	8786	8701	8621	8268	8190	–2171	
	lb	20,235	20,094	19,859	19,370	19,182	19,005	18,227	18,056	–4,786	
Tipping load – straight, rigid tire**	kg	9561	9494	9384	9152	9064	8980	8612	8531	–2262	
	lb	21,078	20,931	20,687	20,177	19,982	19,797	18,987	18,808	–4,985	
Tipping load – full turn, ISO 14397-1*	kg	7894	7836	7737	7524	7445	7371	7070	6999	–1911	
	lb	17,403	17,276	17,057	16,587	16,414	16,251	15,587	15,429	–4,213	
Tipping load – full turn, rigid tire**	kg	8398	8336	8231	8004	7921	7842	7522	7445	–2033	
	lb	18,514	18,378	18,145	17,646	17,461	17,288	16,582	16,414	–4,482	
Breakout force	kg	10 685	9966	9388	10 229	9552	9023	8235	7822	–494	
	lb	23,557	21,972	20,697	22,550	21,059	19,893	18,154	17,245	–1,089	
Operating weight	kg	12 696	12 715	12 778	13 050	13 094	13 132	13 060	13 098	+278	
	lb	27,989	28,031	28,171	28,770	28,867	28,950	28,792	28,876	+613	

*Full compliance to ISO 14397-1 (2007) Sections 1 thru 6, which requires 2% verification between calculation and testing.

**Compliance to ISO 14397-1 (2007) Sections 1 thru 5.

Bucket Specifications

926M Operating Specifications with Buckets

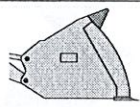
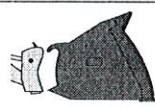
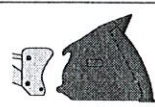

		Light Material								
		 Pin On			 Fusion			 ISO 23727		
Capacity – rated	m ³	3.1	3.5	3.8	3.1	3.5	3.8	3.5	4.1	–
	yd ³	4.1	4.6	5.0	4.0	4.6	5.0	4.6	5.4	–
Capacity – rated at 110% fill factor	m ³	3.4	3.9	4.2	3.4	3.9	4.2	3.9	4.5	–
	yd ³	4.5	5.0	5.5	4.4	5.0	5.5	5.0	5.9	–
17 Width: bucket	mm	2750	2750	2750	2750	2750	2750	2750	2750	–
	ft/in	9'0"	9'0"	9'0"	9'0"	9'0"	9'0"	9'0"	9'0"	–
Nominal material density, 110% fill factor	kg/m ³	1094	951	860	1058	904	817	864	709	–
	lb/yd ³	1,828	1,614	1,441	1,785	1,534	1,369	1,466	1,194	–
9 Clearance: full lift, 45° dump	mm	2703	2631	2573	2672	2600	2543	2527	2407	+505
	ft/in	8'10"	8'7"	8'5"	8'9"	8'6"	8'4"	8'3"	7'10"	+1'7"
14 Reach: full lift, 45° dump	mm	1066	1138	1196	1094	1167	1225	1206	1326	+256
	ft/in	3'5"	3'8"	3'11"	3'7"	3'9"	4'0"	3'11"	4'4"	+10"
Reach: 2130 mm (7'0") clearance, 45° dump	mm	1509	1538	1559	1521	1549	1569	1538	1571	+592
	ft/in	4'11"	5'0"	5'1"	4'11"	5'0"	5'1"	5'0"	5'1"	+1'11"
Reach: level arm, level bucket	mm	2500	2603	2685	2543	2645	2726	2724	2894	+523
	ft/in	8'2"	8'6"	8'9"	8'4"	8'8"	8'11"	8'11"	9'5"	+1'8"
16 Dig depth	mm	100	100	100	100	100	100	125	125	+35
	in	3.9"	3.9"	3.9"	3.9"	3.9"	3.9"	4.9"	4.9"	+1.4"
5 Length: overall	mm	7632	7734	7816	7674	7776	7858	7875	8045	+642
	ft/in	25'0"	25'4"	25'7"	25'2"	25'6"	25'9"	25'10"	26'4"	+2'1"
13 Height: overall	mm	5179	5284	5356	5204	5309	5383	5385	5552	+493
	ft/in	16'11"	17'4"	17'6"	17'0"	17'5"	17'7"	17'8"	18'2"	+1'7"
19 Turning radius: over bucket	mm	6068	6099	6124	6082	6112	6138	6126	6183	+313
	ft/in	19'10"	20'0"	20'1"	19'11"	20'0"	20'1"	20'1"	20'3"	+1'0"
Tipping load – straight, ISO 14397-1*	kg	8719	8566	8424	8359	8181	8042	7824	7543	–2100
	lb	19,221	18,884	18,570	18,428	18,035	17,730	17,248	16,628	–4,630
Tipping load – straight, rigid tire**	kg	9082	8923	8775	8707	8522	8378	8150	7857	–2188
	lb	20,022	19,671	19,344	19,196	18,786	18,469	17,967	17,321	–4,823
Tipping load – full turn, ISO 14397-1*	kg	7463	7321	7190	7124	6957	6830	6652	6390	–1851
	lb	16,452	16,139	15,852	15,706	15,337	15,058	14,664	14,088	–4,080
Tipping load – full turn, rigid tire**	kg	7939	7788	7649	7579	7401	7266	7076	6798	–1969
	lb	17,503	17,169	16,863	16,708	16,316	16,019	15,600	14,987	–4,341
Breakout force	kg	8616	7890	7768	8301	7609	7490	7094	5961	–423
	lb	18,995	17,393	17,124	18,301	16,774	16,513	15,638	13,141	–932
Operating weight	kg	13 006	13 092	13 158	13 337	13 455	13 521	13 375	13 538	+278
	lb	28,674	28,862	29,008	29,403	29,663	29,808	29,487	29,847	+613

*Full compliance to ISO 14397-1 (2007) Sections 1 thru 6, which requires 2% verification between calculation and testing.

**Compliance to ISO 14397-1 (2007) Sections 1 thru 5.

Bucket Specifications

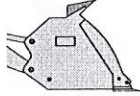
930M Operating Specifications with Buckets



		General Purpose									High Lift
		 Pin On			 Fusion			 ISO 23727			
Capacity – rated	m ³	2.1	2.3	2.5	2.1	2.3	2.5	2.1	2.3	–	
	yd ³	2.7	3.0	3.3	2.7	3.0	3.3	2.7	3.0	–	
Capacity – rated at 110% fill factor	m ³	2.3	2.5	2.8	2.3	2.5	2.8	2.3	2.5	–	
	yd ³	3.0	3.3	3.6	3.0	3.3	3.6	3.0	3.3	–	
17 Width: bucket	mm	2550	2550	2550	2550	2550	2550	2550	2550	–	
	ft/in	8'4"	8'4"	8'4"	8'4"	8'4"	8'4"	8'4"	8'4"	–	
Nominal material density, 110% fill factor	kg/m ³	1921	1733	1571	1833	1658	1505	1742	1575	–	
	lb/yd ³	3,260	2,929	2,645	3,112	2,803	2,535	2,957	2,662	–	
9 Clearance: full lift, 45° dump	mm	2855	2807	2761	2828	2779	2733	2727	2677	+593	
	ft/in	9'4"	9'2"	9'0"	9'3"	9'1"	8'11"	8'11"	8'9"	+1'11"	
14 Reach: full lift, 45° dump	mm	1033	1070	1109	1064	1102	1140	1190	1227	+320	
	ft/in	3'4"	3'6"	3'7"	3'5"	3'7"	3'8"	3'10"	4'0"	+13"	
Reach: 2130 mm (7'0") clearance, 45° dump	mm	1560	1573	1587	1578	1590	1603	1649	1657	+717	
	ft/in	5'1"	5'1"	5'2"	5'2"	5'2"	5'3"	5'4"	5'5"	+2'4"	
Reach: level arm, level bucket	mm	2350	2413	2475	2392	2455	2517	2553	2616	+653	
	ft/in	7'8"	7'11"	8'1"	7'10"	8'0"	8'3"	8'4"	8'6"	+2'1"	
16 Dig depth	mm	100	100	100	100	100	100	94	94	+35	
	in	3.9"	3.9"	3.9"	3.9"	3.9"	3.9"	3.7"	3.7"	+1.4"	
5 Length: overall	mm	7488	7551	7613	7530	7593	7655	7686	7749	+794	
	ft/in	24'6"	24'9"	24'11"	24'8"	24'10"	25'1"	25'2"	25'5"	+2'7"	
13 Height: overall	mm	5122	5180	5239	5147	5205	5264	5255	5313	+593	
	ft/in	16'9"	16'11"	17'2"	16'10"	17'0"	17'3"	17'2"	17'5"	+1'11"	
19 Turning radius: over bucket	mm	5933	5951	5970	5946	5964	5983	5975	5995	+384	
	ft/in	19'5"	19'6"	19'7"	19'6"	19'6"	19'7"	19'7"	19'8"	+1'3"	
Tipping load – straight, ISO 14397-1*	kg	10 370	10 258	10 119	9941	9855	9734	9450	9367	–2823	
	lb	22,862	22,615	22,309	21,915	21,726	21,460	20,834	20,651	–6,222	
Tipping load – straight, rigid tire**	kg	10 802	10 685	10 541	10 355	10 265	10 140	9844	9758	–2940	
	lb	23,814	23,557	23,239	22,828	22,631	22,354	21,702	21,511	–6,482	
Tipping load – full turn, ISO 14397-1*	kg	8873	8769	8639	8469	8390	8278	8047	7971	–2471	
	lb	19,561	19,332	19,045	18,670	18,497	18,249	17,740	17,572	–5,448	
Tipping load – full turn, rigid tire**	kg	9439	9329	9190	9009	8926	8806	8560	8480	–2629	
	lb	20,810	20,566	20,260	19,862	19,678	19,414	18,872	18,694	–5,795	
Breakout force	kg	12 891	12 158	11 488	12 371	11 698	11 080	10 707	10 182	–299	
	lb	28,419	26,803	25,326	27,274	25,790	24,427	23,604	22,448	–658	
Operating weight	kg	13 627	13 691	13 789	14 007	14 044	14 127	13 973	14 011	+232	
	lb	30,042	30,182	30,400	30,879	30,962	31,144	30,804	30,888	+511	

*Full compliance to ISO 14397-1 (2007) Sections 1 thru 6, which requires 2% verification between calculation and testing.

**Compliance to ISO 14397-1 (2007) Sections 1 thru 5.

Bucket Specifications

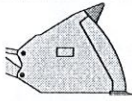
930M Operating Specifications with Buckets



		Light Material								
		 Pin On			 Fusion			 ISO 23727		
Capacity – rated	m ³	3.5	3.8	4.2	3.5	3.8	4.2	3.5	5.0	–
	yd ³	4.6	5.0	5.5	4.6	5.0	5.5	4.6	6.5	–
Capacity – rated at 110% fill factor	m ³	3.9	4.2	4.6	3.9	4.2	4.6	3.9	5.5	–
	yd ³	5.0	5.5	6.0	5.0	5.5	6.0	5.0	7.2	–
17 Width: bucket	mm	2750	2750	2750	2750	2750	2750	2750	2750	–
	ft/in	9'0"	9'0"	9'0"	9'0"	9'0"	9'0"	9'0"	9'0"	–
Nominal material density, 110% fill factor	kg/m ³	1083	981	874	1034	936	834	989	665	–
	lb/yd ³	1,838	1,643	1,484	1,755	1,568	1,416	1,678	1,120	–
9 Clearance: full lift, 45° dump	mm	2631	2573	2510	2600	2543	2480	2527	2357	+607
	ft/in	8'7"	8'5"	8'2"	8'6"	8'4"	8'1"	8'3"	7'8"	+1'11"
14 Reach: full lift, 45° dump	mm	1138	1196	1259	1167	1225	1287	1206	1377	+342
	ft/in	3'8"	3'11"	4'1"	3'9"	4'0"	4'2"	3'11"	4'6"	+13"
Reach: 2130 mm (7'0") clearance, 45° dump	mm	1538	1559	1579	1549	1569	1588	1538	1581	+746
	ft/in	5'0"	5'1"	5'2"	5'0"	5'1"	5'2"	5'0"	5'2"	+2'5"
Reach: level arm, level bucket	mm	2603	2685	2773	2645	2726	2815	2724	2966	+653
	ft/in	8'6"	8'9"	9'1"	8'8"	8'11"	9'2"	8'11"	9'8"	+2'1"
16 Dig depth	mm	100	100	100	100	100	100	125	125	+35
	in	3.9"	3.9"	3.9"	3.9"	3.9"	3.9"	4.9"	4.9"	+1.4"
5 Length: overall	mm	7741	7823	7911	7783	7865	7953	7882	8124	+794
	ft/in	25'4"	25'7"	25'11"	25'6"	25'9"	26'1"	25'10"	26'7"	+2'7"
13 Height: overall	mm	5284	5356	5445	5309	5383	5471	5385	5840	+593
	ft/in	17'4"	17'6"	17'10"	17'5"	17'7"	17'11"	17'8"	19'1"	+1'11"
19 Turning radius: over bucket	mm	6099	6124	6152	6112	6138	6166	6126	6208	+386
	ft/in	20'0"	20'1"	20'2"	20'0"	20'1"	20'2"	20'1"	20'4"	+1'3"
Tipping load – straight, ISO 14397-1*	kg	9796	9643	9512	9395	9247	9118	8988	8667	–2712
	lb	21,596	21,260	20,969	20,713	20,386	20,102	19,814	19,107	–5,978
Tipping load – straight, rigid tire**	kg	10,204	10,045	9908	9787	9632	9498	9362	9028	–2825
	lb	22,496	22,145	21,843	21,576	21,235	20,940	20,639	19,904	–6,227
Tipping load – full turn, ISO 14397-1*	kg	8337	8198	8077	7960	7825	7707	7613	7313	–2377
	lb	18,378	18,072	17,805	17,549	17,251	16,990	16,783	16,121	–5,241
Tipping load – full turn, rigid tire**	kg	8869	8721	8592	8468	8325	8199	8099	7780	–2529
	lb	19,552	19,226	18,942	18,669	18,352	18,075	17,854	17,150	–5,575
Breakout force	kg	10,278	10,140	9024	9926	9792	8740	9293	7810	–250
	lb	22,658	22,354	19,895	21,883	21,588	19,267	20,488	17,218	–551
Operating weight	kg	14,004	14,070	14,134	14,367	14,433	14,497	14,288	14,510	+232
	lb	30,874	31,019	31,160	31,674	31,819	31,960	31,498	31,990	+511

*Full compliance to ISO 14397-1 (2007) Sections 1 thru 6, which requires 2% verification between calculation and testing.

**Compliance to ISO 14397-1 (2007) Sections 1 thru 5.

Bucket Specifications

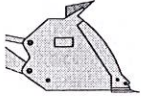
938M Operating Specifications with Buckets

		General Purpose									High Lift
		 Pin On			 Fusion			 ISO 23727			
Capacity – rated	m ³	2.5	2.7	2.9	2.5	2.7	2.9	2.5	2.7	–	
	yd ³	3.3	3.5	3.8	3.3	3.5	3.8	3.3	3.5	–	
Capacity – rated at 110% fill factor	m ³	2.8	3.0	3.2	2.8	3.0	3.2	2.8	3.0	–	
	yd ³	3.6	3.9	4.2	3.6	3.9	4.2	3.6	3.9	–	
17 Width: bucket	mm	2750	2750	2750	2750	2750	2750	2750	2750	–	
	ft/in	9'0"	9'0"	9'0"	9'0"	9'0"	9'0"	9'0"	9'0"	–	
Nominal material density, 110% fill factor	kg/m ³	1912	1755	1622	1823	1673	1546	1751	1605	–	
	lb/yd ³	3,220	2,947	2,716	3,070	2,809	2,589	2,949	2,695	–	
9 Clearance: full lift, 45° dump	mm	2869	2822	2786	2834	2787	2751	2739	2691	+581	
	ft/in	9'4"	9'3"	9'1"	9'3"	9'1"	9'0"	8'11"	8'9"	+1'10"	
14 Reach: full lift, 45° dump	mm	1108	1146	1178	1146	1185	1216	1264	1302	+267	
	ft/in	3'7"	3'9"	3'10"	3'9"	3'10"	3'11"	4'1"	4'3"	+11"	
Reach: 2130 mm (7'0") clearance, 45° dump	mm	1637	1652	1664	1658	1672	1684	1725	1736	+666	
	ft/in	5'4"	5'5"	5'5"	5'5"	5'5"	5'6"	5'7"	5'8"	+2'2"	
Reach: level arm, level bucket	mm	2452	2514	2563	2504	2566	2615	2655	2717	+607	
	ft/in	8'0"	8'2"	8'4"	8'2"	8'5"	8'6"	8'8"	8'10"	+1'11"	
16 Dig depth	mm	100	100	100	101	101	101	94	94	+35	
	in	3.9"	3.9"	3.9"	4"	4"	4"	3.7"	3.7"	+1.4"	
5 Length: overall	mm	7604	7666	7715	7656	7718	7767	7802	7864	+740	
	ft/in	24'11"	25'1"	25'3"	25'1"	25'3"	25'5"	25'7"	25'9"	+2'5"	
13 Height: overall	mm	5242	5301	5348	5273	5332	5379	5375	5434	+581	
	ft/in	17'2"	17'4"	17'6"	17'3"	17'5"	17'7"	17'7"	17'9"	+1'10"	
19 Turning radius: over bucket	mm	6117	6136	6150	6134	6152	6167	6160	6180	+357	
	ft/in	20'0"	20'1"	20'2"	20'1"	20'2"	20'2"	20'2"	20'3"	+1'2"	
Tipping load – straight, ISO 14397-1*	kg	12 344	12 245	12 161	11 820	11 721	11 641	11 349	11 245	-3607***	
	lb	27,214	26,995	26,810	26,057	25,840	25,663	25,019	24,791	-7,952	
Tipping load – straight, rigid tire**	kg	12 859	12 755	12 668	12 312	12 210	12 126	11 822	11 714	-3757***	
	lb	28,348	28,120	27,928	27,143	26,917	26,732	26,062	25,824	-8,284	
Tipping load – full turn, ISO 14397-1*	kg	10 517	10 426	10 350	10 028	9938	9864	9632	9536	-3125***	
	lb	23,186	22,986	22,817	22,107	21,909	21,747	21,234	21,024	-6,890	
Tipping load – full turn, rigid tire**	kg	11 189	11 092	11 011	10 668	10 572	10 494	10 246	10 145	-3325***	
	lb	24,666	24,453	24,274	23,518	23,307	23,135	22,589	22,366	-7,330	
Breakout force	kg	13 813	13 082	12 552	13 170	12 498	12 009	11 583	11 039	-502	
	lb	30,451	28,841	27,673	29,035	27,553	26,474	25,537	24,336	-1,107	
Operating weight	kg	16 001	16 046	16 082	16 427	16 472	16 508	16 316	16 367	-102***	
	lb	35,276	35,374	35,455	36,216	36,313	36,393	35,970	36,083	-224	



*Full compliance to ISO 14397-1 (2007) Sections 1 thru 6, which requires 2% verification between calculation and testing.

**Compliance to ISO 14397-1 (2007) Sections 1 thru 5.

***938M High Lift is configured with standard counterweight.

Bucket Specifications

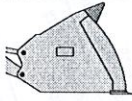
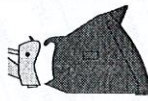
938M Operating Specifications with Buckets

		Light Material									High Lift
		 Pin On			 Fusion			 ISO 23727			
Capacity – rated	m ³	3.8	4.2	5.0	3.8	4.2	5.0	4.2	5.0	–	
	yd ³	5.0	5.5	6.5	5.0	5.5	6.5	5.4	6.5	–	
Capacity – rated at 110% fill factor	m ³	4.2	4.6	5.5	4.2	4.6	5.5	4.5	5.5	–	
	yd ³	5.5	6.0	7.2	5.5	6.0	7.2	5.9	7.2	–	
17 Width: bucket	mm	2750	2750	2750	2750	2750	2750	2750	2750	–	
	ft/in	9'0"	9'0"	9'0"	9'0"	9'0"	9'0"	9'0"	9'0"	–	
Nominal material density, 110% fill factor	kg/m ³	1198	1068	897	1141	1019	853	1005	822	–	
	lb/yd ³	2,007	1,813	1,510	1,912	1,730	1,437	1,693	1,384	–	
9 Clearance: full lift, 45° dump	mm	2633	2571	2571	2596	2534	2534	2468	2417	+598	
	ft/in	8'7"	8'5"	8'5"	8'6"	8'3"	8'3"	8'1"	7'11"	+1'11"	
14 Reach: full lift, 45° dump	mm	1232	1294	1294	1268	1331	1331	1362	1413	+292	
	ft/in	4'0"	4'2"	4'2"	4'1"	4'4"	4'4"	4'5"	4'7"	+11"	
Reach: 2130 mm (7'0") clearance, 45° dump	mm	1631	1654	1654	1644	1666	1666	1650	1664	+695	
	ft/in	5'4"	5'5"	5'5"	5'4"	5'5"	5'5"	5'4"	5'5"	+2'3"	
Reach: level arm, level bucket	mm	2723	2812	2812	2775	2864	2864	2932	3004	+607	
	ft/in	8'11"	9'2"	9'2"	9'1"	9'4"	9'4"	9'7"	9'10"	+1'11"	
16 Dig depth	mm	100	100	100	101	101	101	125	125	+35	
	in	3.9"	3.9"	3.9"	4"	4"	4"	4.9"	4.9"	+1.4"	
5 Length: overall	mm	7875	7964	7964	7928	8016	8016	8105	8177	+740	
	ft/in	25'10"	26'1"	26'1"	26'0"	26'3"	26'3"	26'7"	26'9"	+2'5"	
13 Height: overall	mm	5418	5507	5786	5450	5539	5820	5614	5902	+581	
	ft/in	17'9"	18'0"	18'11"	17'10"	18'2"	19'1"	18'5"	19'4"	+1'10"	
19 Turning radius: over bucket	mm	6198	6227	6227	6216	6244	6244	6258	6282	+365	
	ft/in	20'4"	20'5"	20'5"	20'4"	20'5"	20'5"	20'6"	20'7"	+1'2"	
Tipping load – straight, ISO 14397-1*	kg	11 794	11 637	11 636	11 289	11 151	11 120	10 728	10 713	–3443***	
	lb	26,002	25,654	25,653	24,887	24,582	24,515	23,652	23,617	–7,591	
Tipping load – straight, rigid tire**	kg	12 286	12 122	12 121	11 759	11 615	11 583	11 175	11 159	–3586***	
	lb	27,085	26,723	26,722	25,924	25,607	25,537	24,637	24,601	–7,907	
Tipping load – full turn, ISO 14397-1*	kg	10 015	9870	9866	9542	9416	9383	9059	9040	–2986***	
	lb	22,078	21,758	21,750	21,037	20,759	20,686	19,972	19,930	–6,583	
Tipping load – full turn, rigid tire**	kg	10 654	10 499	10 495	10 152	10 017	9982	9638	9617	–3177***	
	lb	23,487	23,147	23,138	22,380	22,084	22,007	21,247	21,202	–7,004	
Breakout force	kg	11 603	10 331	10 292	11 122	9942	9888	9023	8977	–437	
	lb	25,581	22,775	22,690	24,519	21,918	21,798	19,891	19,791	–963	
Operating weight	kg	16 270	16 347	16 394	16 694	16 757	16 835	16 653	16 713	–102***	
	lb	35,870	36,039	36,143	36,802	36,943	37,114	36,713	36,845	–224	

*Full compliance to ISO 14397-1 (2007) Sections 1 thru 6, which requires 2% verification between calculation and testing.

**Compliance to ISO 14397-1 (2007) Sections 1 thru 5.

***938M High Lift is configured with standard counterweight.

Bucket Selection Tables

General Purpose Bucket Selection – Standard Lift

Material Type		Fill Factor %		Material Type													Tip Load Full Turn*										
		m ³	yd ³	105% Sand, Dry and Loose Clay and Gravel, Dry	110% Clay, Natural Bed, Dry	105% Sandstone	105% Limestone	110% Clay and Gravel, Crushed	105% Sand and Gravel, Wet	115% 25% Rock, 75% Earth	105% Gypsum, Crushed	105% Granite, Broken	110% Clay, Natural Bed, Wet	105% Sand and Gravel, Dry	110% Sand, Damp	115% 50% Rock, 50% Earth	110% Sand, Wet	110% Gravel, Pitrun	115% 75% Rock, 25% Earth	110% Sand and Gravel, Wet	kg	lb					
		Counter-weight	kg/m ³ lb/yd ³	1400 (2,359)	1475 (2,485)	1550 (2,612)	1625 (2,738)	1700 (2,865)	1775 (2,991)	1850 (3,117)	1925 (3,244)	2000 (3,370)	2075 (3,496)	2150 (3,623)							kg	lb					
926M	Pin On	1.9 (2.5)	Log/Agg							115%	110%	105%	100%								8318	(18,338)					
			Heavy																			7894	(17,403)				
		2.1 (2.7)	Log/Agg						115%	110%	105%	100%											8257	(18,204)			
			Heavy					115%	110%	105%	100%												7836	(17,275)			
		2.3 (3.0)	Log/Agg																				8156	(17,980)			
			Heavy	115%	110%	105%	100%																7737	(17,057)			
	Fusion	1.9 (2.5)	Log/Agg								115%	110%	105%	100%								7942	(17,509)				
			Heavy																			7524	(16,587)				
		2.1 (2.7)	Log/Agg						115%	110%	105%	100%											7862	(17,333)			
			Heavy					115%	110%	105%	100%												7445	(16,413)			
		2.3 (3.0)	Log/Agg																					7783	(17,159)		
			Heavy	115%	110%	105%	100%																	7371	(16,250)		
930M	Pin On	2.1 (2.7)	Log/Agg							115%	110%	105%	100%								9295	(20,491)					
			Heavy																			8873	(19,561)				
		2.3 (3.0)	Log/Agg						115%	110%	105%	100%											9186	(20,252)			
			Heavy																				8769	(19,332)			
		2.5 (3.3)	Log/Agg																					9055	(19,962)		
			Heavy					115%	110%	105%	100%												8639	(19,045)			
	Fusion	2.1 (2.7)	Log/Agg								115%	110%	105%	100%									8883	(19,583)			
			Heavy																				8469	(18,670)			
		2.3 (3.0)	Log/Agg						115%	110%	105%	100%												8804	(19,410)		
			Heavy																				8390	(18,497)			
		2.5 (3.3)	Log/Agg																					8690	(19,158)		
			Heavy	115%	110%	105%	100%																	8278	(18,249)		
938M	Pin On	2.5 (3.3)	Log/Agg							115%	110%	105%	100%									10 925	(24,085)				
			Heavy																				10 517	(23,186)			
		2.7 (3.5)	Log/Agg						115%	110%	105%	100%												10 015	(22,079)		
			Heavy																					10 832	(23,881)		
		2.9 (3.8)	Log/Agg																						10 426	(22,985)	
			Heavy						115%	110%	105%	100%												9925	(21,881)		
	Fusion	2.5 (3.3)	Log/Agg								115%	110%	105%	100%											10 753	(23,706)	
			Heavy																					10 350	(22,817)		
		2.7 (3.5)	Log/Agg						115%	110%	105%	100%													9854	(21,724)	
			Heavy																						10 430	(22,994)	
		2.9 (3.8)	Log/Agg																							10 028	(22,107)
			Heavy																							10 341	(22,798)

Material density, fill factor, and counterweight options are key variables when choosing the appropriate size of the bucket. The long floor and open throat design of the Performance Series Buckets along with the aggressive rack angles of the optimized linkage will demonstrate fill factors greater than 100% ISO rated. Refer to the expected fill factor % per material type at the top of the table and find a matching counterweight and fill factor along the side for proper bucket sizing.

*Full compliance to ISO 14397-1 (2007) Sections 1 thru 6, which requires 2% verification between calculation and testing.

Bucket Selection Tables

Light Material Bucket Selection – Standard Lift

Material Type		Fill Factor %													Tip Load Full Turn*		
		100%	110%	115%	110%	110%	110%	110%	105%	105%	110%	110%	110%	110%			110%
926M	Pin On	m ³	Counter-weight	kg/m ³	805	850	895	940	985	1030	1075	1120	1165	1210	1255	kg	lb
		yd ³	lb/yd ³	lb/yd ³	(1,356)	(1,432)	(1,508)	(1,584)	(1,660)	(1,736)	(1,811)	(1,887)	(1,963)	(2,039)	(2,115)		
926M	Pin On	3.1	Log/Agg													7880	(17,372)
		3.1	Heavy													7463	(16,453)
		3.5	Log/Agg													7735	(17,052)
		3.5	Heavy													7321	(16,140)
		3.8	Log/Agg													7600	(16,755)
		3.8	Heavy													7190	(15,850)
	Fusion	3.1	Log/Agg													7533	(16,607)
		3.1	Heavy													7124	(15,705)
		3.5	Log/Agg													7364	(16,234)
		3.5	Heavy													6957	(15,337)
		3.8	Log/Agg													7235	(15,950)
		3.8	Heavy													6830	(15,057)
930M	Pin On	3.5	Log/Agg													8750	(19,290)
		3.5	Heavy												8337	(18,379)	
		3.8	Log/Agg												8603	(18,966)	
		3.8	Heavy												8198	(18,073)	
		4.2	Log/Agg												8484	(18,704)	
		4.2	Heavy												8077	(17,806)	
	Fusion	3.5	Log/Agg													8365	(18,441)
		3.5	Heavy												7960	(17,548)	
		3.8	Log/Agg												8231	(18,145)	
		3.8	Heavy												7825	(17,251)	
		4.2	Log/Agg												8106	(17,870)	
		4.2	Heavy												7707	(16,991)	
938M	Pin On	3.8	Log/Agg													10412	(22,954)
		3.8	Heavy												10015	(22,079)	
		4.2	Log/Agg												10265	(22,630)	
		4.2	Heavy												9870	(21,759)	
		5.0	Log/Agg												10260	(22,619)	
		5.0	Heavy												9866	(21,750)	
	Fusion	3.8	Log/Agg													9933	(21,898)
		3.8	Heavy												9542	(21,036)	
		4.2	Log/Agg												9811	(21,629)	
		4.2	Heavy												9416	(20,759)	
		5.0	Log/Agg												9770	(21,539)	
		5.0	Heavy												9383	(20,685)	

Material density, fill factor, and counterweight options are key variables when choosing the appropriate size of the bucket. The long floor and open throat design of the Performance Series Buckets along with the aggressive rack angles of the optimized linkage will demonstrate fill factors greater than 100% ISO rated. Refer to the expected fill factor % per material type at the top of the table and find a matching counterweight and fill factor along the side for proper bucket sizing.

*Full compliance to ISO 14397-1 (2007) Sections 1 thru 6, which requires 2% verification between calculation and testing.

Bucket Selection Tables

General Purpose Bucket Selection – High Lift

Material Type		Fill Factor %														Tip Load Full Turn*			
		105% Fertilizer, Mixed	110% Coal Anthracite, Washed	110% Gypsum, Pulverized	110% Peat, Wet	110% Coal Anthracite, Raw	110% Earth, Loam, Dry	105% Salt, Fine	110% Heavy Metal Scrap, Loose	110% Slate	1345	1390 Sand, Dry and Loose Clay and Gravel, Dry	1435	1480 Clay, Natural Bed, Dry					
926M High Lift	Pin On	m ²	Counter-weight	kg/m ³	1030	1075	1120	1165	1210	1255	1300	1345	1390	1435	1480	kg	lb		
		yd ²	lb/yd ³	(1,736)	(1,811)	(1,887)	(1,963)	(2,039)	(2,115)	(2,191)	(2,266)	(2,342)	(2,418)	(2,494)					
926M High Lift	Pin On	1.9	Log/Agg Heavy	Not Available								115%	110%			5970	(13,161)		
		2.1	Log/Agg Heavy	Not Available					115%	110%		105%					5926	(13,065)	
		2.3	Log/Agg Heavy	Not Available					105%	100%							5837	(12,869)	
		1.9	Log/Agg Heavy	Not Available							115%	110%		105%			5628	(12,407)	
		2.1	Log/Agg Heavy	Not Available							100%						5561	(12,259)	
		2.3	Log/Agg Heavy	Not Available	115%	110%	105%	100%									5497	(12,118)	
	930M High Lift	Pin On	2.1	Log/Agg Heavy	Not Available								115%	110%	105%		6384	(14,074)	
			2.3	Log/Agg Heavy	Not Available					115%	110%	105%			100%		5989	(13,203)	
			2.5	Log/Agg Heavy	Not Available					105%	100%						6297	(13,883)	
			2.1	Log/Agg Heavy	Not Available						115%	110%	105%	100%			6185	(13,635)	
			2.3	Log/Agg Heavy	Not Available					115%	110%	105%	100%				5795	(12,775)	
			2.5	Log/Agg Heavy	Not Available	115%	110%	105%	100%								6014	(13,259)	
930M High Lift		Fusion	2.1	Log/Agg Heavy	Not Available						115%	110%	105%	100%			5952	(13,122)	
			2.3	Log/Agg Heavy	Not Available					115%	110%	105%	100%				5860	(12,919)	
			2.5	Log/Agg Heavy	Not Available	115%	110%	105%	100%										
			2.1	Log/Agg Heavy	Not Available														
			2.3	Log/Agg Heavy	Not Available														
			2.5	Log/Agg Heavy	Not Available														
938M High Lift	Pin On	2.5	Log/Agg Heavy	Not Available															
		2.7	Log/Agg Heavy	Not Available															
		2.9	Log/Agg Heavy	Not Available															
		2.5	Log/Agg Heavy	Not Available															
		2.7	Log/Agg Heavy	Not Available															
		2.9	Log/Agg Heavy	Not Available															
	938M High Lift	Fusion	2.5	Log/Agg Heavy	Not Available														
			2.7	Log/Agg Heavy	Not Available														
			2.9	Log/Agg Heavy	Not Available														
			2.5	Log/Agg Heavy	Not Available														
			2.7	Log/Agg Heavy	Not Available														
			2.9	Log/Agg Heavy	Not Available														

Material density, fill factor, and counterweight options are key variables when choosing the appropriate size of the bucket. The long floor and open throat design of the Performance Series Buckets along with the aggressive rack angles of the optimized linkage will demonstrate fill factors greater than 100% ISO rated. Refer to the expected fill factor % per material type at the top of the table and find a matching counterweight and fill factor along the side for proper bucket sizing.

*Full compliance to ISO 14397-1 (2007) Sections 1 thru 6, which requires 2% verification between calculation and testing.

Bucket Selection Tables

Light Material Bucket Selection – High Lift

Material Type		Fill Factor %													Tip Load Full Turn*			
		115% Mulch, Wet	115% Municipal Solid Waste	110% Four-Wheat	115% Compacted Solid Waste	100% Barley, Bulk	100% Buckwheat, Bulk	110% Asphalt, Crushed	100% Soy Beans, Bulk	100% Corn Shelled, Bulk	105% Glass, Semi Crushed	100% Wheat, Bulk	110% Construction and Demolition	115% Silage, Packed			110% Manure/Muck, Wet	
926M High Lift	Pin On	m ³	Counter-weight	kg/m ³	550	580	610	640	670	700	730	760	790	820	850	kg	lb	
		yd ³	lb/yd ³	(927)	(977)	(1,028)	(1,078)	(1,129)	(1,180)	(1,230)	(1,281)	(1,331)	(1,382)	(1,432)				
926M High Lift	Pin On	3.1	Log/Agg Heavy	Not Available												5587	(12,317)	
		3.5	Log/Agg Heavy	Not Available									115%	110%	105%			100%
		3.8	Log/Agg Heavy	Not Available			115%	110%	105%	100%								
	Fusion	3.1	Log/Agg Heavy	Not Available												5273	(11,625)	
		3.5	Log/Agg Heavy	Not Available							115%	110%		105%	100%			
		3.8	Log/Agg Heavy	Not Available			115%	110%	105%	100%								
930M High Lift	Pin On	3.5	Log/Agg Heavy	Not Available												5929	(13,071)	
		3.8	Log/Agg Heavy	Not Available														
		4.2	Log/Agg Heavy	Not Available														
	Fusion	3.5	Log/Agg Heavy	Not Available												5586	(12,315)	
		3.8	Log/Agg Heavy	Not Available														
		4.2	Log/Agg Heavy	Not Available														
938M High Lift	Pin On	3.8	Log/Agg Heavy	Not Available												6977	(15,381)	
		4.2	Log/Agg Heavy	Not Available														
		5.0	Log/Agg Heavy	Not Available														
	Fusion	3.8	Log/Agg Heavy	Not Available												6559	(14,459)	
		4.2	Log/Agg Heavy	Not Available														
		5.0	Log/Agg Heavy	Not Available														

Material density, fill factor, and counterweight options are key variables when choosing the appropriate size of the bucket. The long floor and open throat design of the Performance Series Buckets along with the aggressive rack angles of the optimized linkage will demonstrate fill factors greater than 100% ISO rated. Refer to the expected fill factor % per material type at the top of the table and find a matching counterweight and fill factor along the side for proper bucket sizing.

*Full compliance to ISO 14397-1 (2007) Sections 1 thru 6, which requires 2% verification between calculation and testing.

Operating Specifications

Operating Specifications with Forks

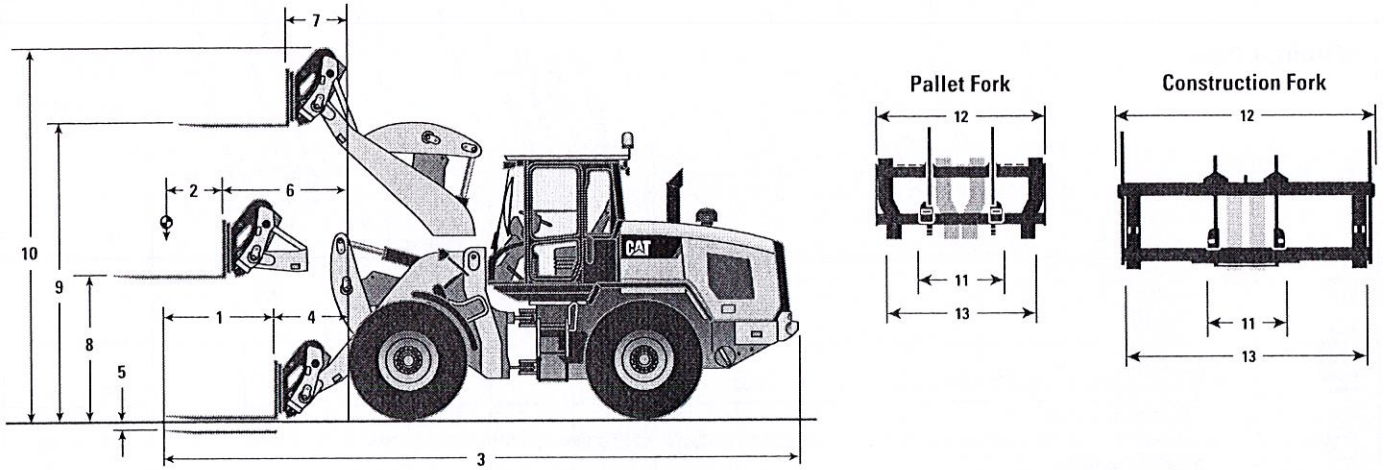

	Pallet Fork – Fusion						Construction Fork – Fusion					
	926M		930M		938M		926M		930M		938M	
	mm	ft/in	mm	ft/in	mm	ft/in	mm	ft/in	mm	ft/in	mm	ft/in
1 Fork tine length	1220	4'0"	1220	4'0"	1220	4'0"	1524	5'0"	1524	5'0"	1524	5'0"
2 Load center	610	2'0"	610	2'0"	610	2'0"	762	2'6"	762	2'6"	762	2'5"
3 Length: overall	7875	25'10"	7882	25'10"	7942	26'0"	8298	27'2"	8305	27'2"	8366	27'5"
4 Reach: ground	926	3'0"	926	3'0"	961	3'1"	1045	3'5"	1045	3'5"	1081	3'6"
5 Dig depth	47	1.9"	47	1.9"	44	1.7"	120	4.7"	120	4.7"	119	4.7"
6 Reach: level arm	1569	5'1"	1569	5'1"	1617	5'3"	1627	5'4"	1627	5'4"	1675	5'5"
7 Reach: full lift	767	2'6"	767	2'6"	814	2'8"	825	2'8"	825	2'8"	872	2'10"
8 Clearance: level arm	1792	5'10"	1792	5'10"	1830	6'0"	1729	5'8"	1729	5'8"	1766	5'9"
9 Clearance: full lift	3693	12'1"	3693	12'1"	3758	12'3"	3630	11'10"	3630	11'10"	3693	12'1"
10 Height: overall	4676	15'4"	4676	15'4"	4740	15'6"	4935	16'2"	4935	16'2"	0	0'0"
11 Minimum fork spacing	300	0'11"	300	0'11"	300	0'11"	300	0'11"	300	0'11"	300	0'11"
12 Carriage width	1566	5'1"	1566	5'1"	1566	5'1"	2498	8'2"	2498	8'2"	2498	8'2"
13 Maximum fork spacing	1550	5'1"	1550	5'1"	1550	5'1"	2375	7'9"	2375	7'9"	2375	7'9"
	kg	lb	kg	lb	kg	lb	kg	lb	kg	lb	kg	lb
Tipping load – straight, ISO 14397-1*	6756	14,895	7689	16,951	9274	20,445	6049	13,335	6919	15,254	8405	18,528
Tipping load – full turn, ISO 14397-1*	5807	12,801	6577	14,499	7909	17,437	5168	11,394	5887	12,978	7136	15,731
Operating weight	12 759	28,129	13 671	30,140	15 932	35,123	13 094	28,866	14 006	30,877	16 266	35,861
Rated load % of full turn tip:												
50% of tip: SAE J1197**	2903	6,400	3288	7,249	3955	8,718	2584	5,697	2943	6,489	3568	7,865
60% of tip: rough terrain EN474-3**	3484	7,680	3946	8,699	4746	10,462	3101	6,836	3532	7,786	4281	9,438
80% of tip: firm and level EN474-3**	4645	10,240	5261	11,599	6327	13,949	4135	9,115	4709	10,382	5708	12,584

*Full compliance to ISO 14397-1 (2007) Sections 1 thru 6, which requires 2% verification between calculation and testing.

**Full compliance to EN474-3 and SAE J1197.

Operating Specifications

Operating Specifications with Material Handling Arm

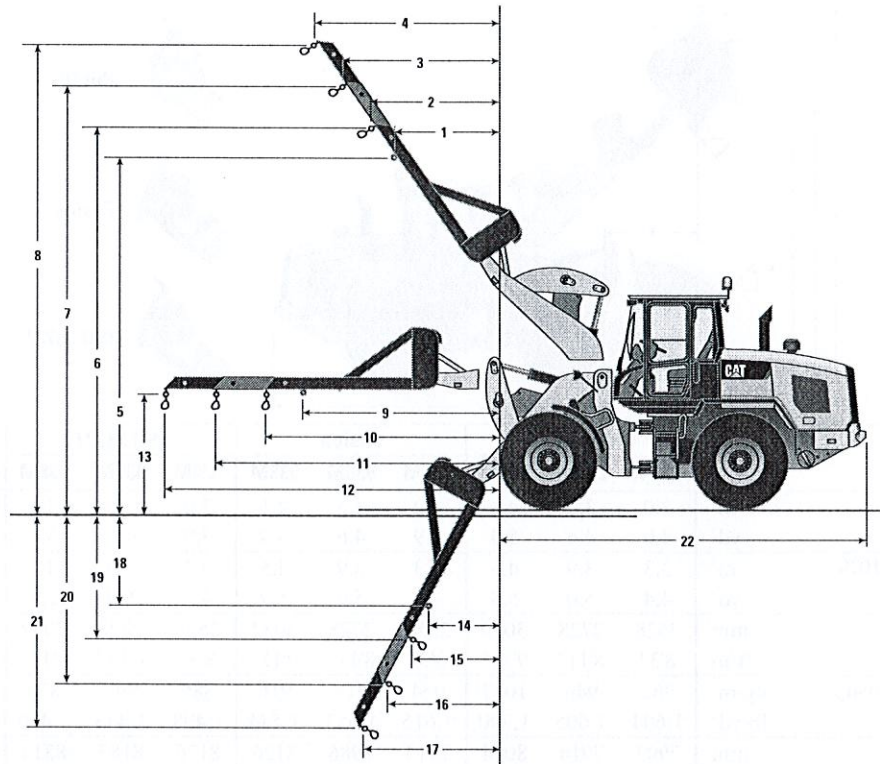

Material Handling Arm – Fusion

	926M		930M		938M			926M		930M		938M	
1	2113 mm	6'11"	2113 mm	6'11"	2144 mm	7'0"	12	5327 mm	17'5"	5327 mm	17'5"	5376 mm	17'7"
2	2333 mm	7'7"	2333 mm	7'7"	2362 mm	7'8"	13	1854 mm	6'0"	1854 mm	6'0"	1890 mm	6'2"
3	2919 mm	9'6"	2919 mm	9'6"	2943 mm	9'7"	14	863 mm	2'9"	863 mm	2'9"	906 mm	2'11"
4	3505 mm	11'6"	3505 mm	11'6"	3525 mm	11'6"	15	1045 mm	3'5"	1045 mm	3'5"	1089 mm	3'6"
5	5257 mm	17'2"	5257 mm	17'2"	5343 mm	17'6"	16	1276 mm	4'2"	1276 mm	4'2"	1324 mm	4'4"
6	5568 mm	18'3"	5568 mm	18'3"	5655 mm	18'6"	17	1507 mm	4'11"	1507 mm	4'11"	1559 mm	5'1"
7	6112 mm	20'0"	6112 mm	20'0"	6204 mm	20'4"	18	1975 mm	6'5"	1975 mm	6'5"	1983 mm	6'6"
8	6657 mm	21'10"	6657 mm	21'10"	6754 mm	22'1"	19	2310 mm	7'6"	2310 mm	7'6"	2316 mm	7'7"
9	3354 mm	11'0"	3354 mm	11'0"	3403 mm	11'1"	20	3076 mm	10'1"	3076 mm	10'1"	3081 mm	10'1"
10	3727 mm	12'2"	3727 mm	12'2"	3775 mm	12'4"	21	3842 mm	12'7"	3842 mm	12'7"	3846 mm	12'7"
11	4527 mm	14'10"	4527 mm	14'10"	4575 mm	15'0"	22	5730 mm	18'9"	5737 mm	18'9"	5762 mm	18'10"

	926M		930M		938M	
Operating weight	12 626 kg	27,835 lb	13 538 kg	29,847 lb	15 799 kg	34,830 lb
Rated load* (50% of full turn tip** SAE J1197)						
Fixed tab (9)	2081 kg	4,588 lb	2356 kg	5,193 lb	2844 kg	6,269 lb
Minimum extension (10)	1908 kg	4,205 lb	2159 kg	4,760 lb	2610 kg	5,753 lb
Middle extension (11)	1618 kg	3,567 lb	1832 kg	4,037 lb	2217 kg	4,887 lb
Maximum extension (12)	1405 kg	3,097 lb	1590 kg	3,505 lb	1927 kg	4,248 lb

*Full compliance to ISO 14397-1 (2007) Sections 1 thru 6, which requires 2% verification between calculation and testing.

**Full compliance to EN474-3 and SAE J1197.

Operating Specifications

Operating Specifications with High Dump Buckets

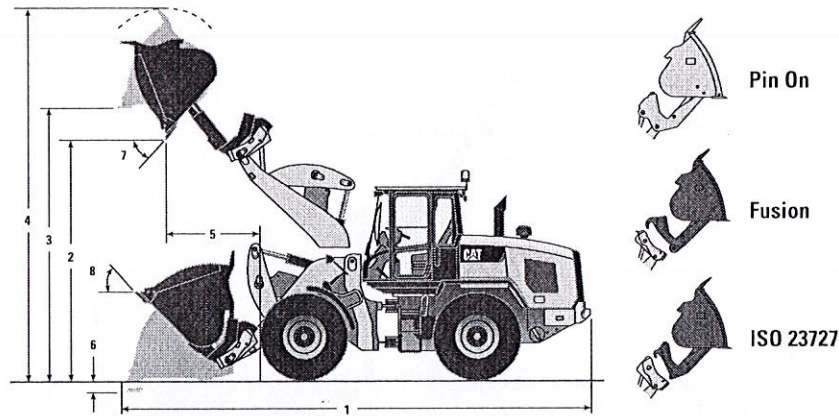

		Pin On			Fusion			ISO 23727			High Lift		
		926M	930M	938M	926M	930M	938M	926M	930M	938M	926M	930M	938M
Rated Capacity	m ³	3.0	3.5	4.1	3.0	3.5	4.1	3.0	3.5	4.1	-	-	-
	yd ³	4.0	4.6	5.4	3.9	4.6	5.4	3.9	4.6	5.4	-	-	-
Capacity – Rated at 110%	m ³	3.3	3.9	4.5	3.3	3.9	4.5	3.3	3.9	4.5	-	-	-
Fill Factor	yd ³	4.4	5.0	5.9	4.3	5.0	5.9	4.3	5.0	5.9	-	-	-
Bucket Width	mm	2528	2728	3030	2528	2728	3032	2528	2728	3032	-	-	-
	ft/in	8'3"	8'11"	9'11"	8'3"	8'11"	9'11"	8'3"	8'11"	9'11"	-	-	-
Nominal Material Density	kg/m ³	962	946	1062	954	915	916	885	867	878	-	-	-
110% Fill Factor	lb/yd ³	1,604	1,605	1,790	1,615	1,553	1,544	1,498	1,473	1,480	-	-	-
1 Length: Overall	mm	7907	7914	8044	7913	7986	8126	8176	8183	8313	+642	+794	+737
	ft/in	25'11"	25'11"	26'4"	25'11"	26'2"	26'7"	26'9"	26'10"	27'3"	+2'1"	+2'7"	+2'5"
2 Dump Clearance:	mm	4252	4252	4264	4275	4332	4354	4399	4523	4539	+440	+568	+545
Full Lift Rolled Out	ft/in	13'11"	13'11"	13'11"	14'0"	14'2"	14'3"	14'5"	14'10"	14'10"	+1'5"	+1'10"	+1'9"
3 Clearance: Level Bucket	mm	4592	4592	4647	4606	4609	4725	4751	4849	4904	+451	+574	+553
	ft/in	15'0"	15'0"	15'2"	15'1"	15'1"	15'6"	15'7"	15'10"	16'1"	+1'5"	+1'10"	+1'9"
4 Height: Overall	mm	6255	6298	6367	6268	6315	6446	6413	6555	6605	+451	+574	+553
	ft/in	20'6"	20'7"	20'10"	20'6"	20'8"	21'1"	21'0"	21'6"	21'8"	+1'5"	+1'10"	+1'9"
5 Reach: Full Lift Rolled Out	mm	1425	1425	1489	1421	1458	1530	1613	1561	1626	+253	+329	+278
	ft/in	4'8"	4'8"	4'10"	4'7"	4'9"	5'0"	5'3"	5'1"	5'4"	+0'9"	+1'0"	+0'10"
6 Dig Depth	mm	80	80	96	100	100	116	94	94	109	+35	+35	+35
	in	3.2"	3.2"	3.8"	3.9"	3.9"	4.6"	3.7"	3.7"	4.3"	+1.4"	+1.4"	+1.4"
7 Maximum Dump Angle	degree	52	52	51	50	49	49	55	48	48	-	-	-
8 Rack Angle at Carry	degree	43	43	55	45	45	46	43	43	44	-	-	-
Tipping Load –	kg	7560	8637	11 395	7465	8389	9903	6941	7967	9494	-1946	-2473	-3161***
Straight ISO 14397-1*	lb	16,666	19,041	25,120	16,457	18,495	21,832	15,301	17,564	20,931	-4,290	-5,450	-6,966
Tipping Load –	kg	7875	8997	11 869	7776	8739	10 315	7230	8299	9890	-2027	-2576	-3292***
Straight Rigid Tire**	lb	17,360	19,834	26,167	17,143	19,265	22,741	15,938	18,295	21,803	-4,469	-5,677	-7,256
Tipping Load –	kg	6404	7281	9580	6299	7043	8266	5844	6680	7921	-1717	-2171	-2742***
Full Turn ISO 14397-1*	lb	14,117	16,051	21,119	13,886	15,528	18,223	12,884	14,726	17,462	-3,784	-4,784	-6,043
Tipping Load –	kg	6812	7746	10 191	6701	7493	8794	6217	7106	8426	-1826	-2309	-2917***
Full Turn Rigid Tire**	lb	15,018	17,076	22,467	14,773	16,519	19,386	13,706	15,666	18,577	-4,026	-5,089	-6,429
Breakout Force	kg	6560	8584	9491	6727	8373	8959	5500	7258	7845	-361	-219	-369
	lb	14,463	18,925	20,923	14,829	18,458	19,750	12,125	16,000	17,295	-795	-482	-812
Operating Weight	kg	13 531	14 534	17 014	13 834	14 836	17 427	13 793	14 795	17 327	+278	+232	-102***
	lb	29,830	32,042	37,509	30,499	32,706	38,419	30,409	32,616	38,199	612	511	-224

*Full compliance to ISO 14397-1 (2007) Sections 1 thru 6, which requires 2% verification between calculation and testing.

**Compliance to ISO 14397-1 (2007) Sections 1 thru 5.

***938M High Lift is configured with standard counterweight.

Bucket Selection Tables

High Dump Bucket Selection – Standard Lift

		Material Type		Fill Factor %												Tip Load Full Turn*						
				Mulch, Wet	Municipal Solid Waste Flour, Wheat	Compacted Solid Waste Barley, Bulk	Asphalt, Crushed	Soy Beans, Bulk	Corn Shelled, Bulk	Glass, Semi Crushed	Bulk Grain	Construction and Demolition Silage, Packed	Manure/Muck, Wet	Coal Bituminous, Washed	Coal Bituminous, Raw			Sugar, Raw Cane	Fertilizer, Mixed	Coal Anthracite, Washed		
Model	Pin On / Fusion	m ³ / yd ³	Counter-weight / kg/m ³ / lb/yd ³	Fill Factor %												kg	lb					
				115%	115%	110%	115%	110%	105%	100%	110%	100%	105%	110%	105%			100%	110%	105%	100%	
926M	Pin On	3.0 (3.9)	Log/Agg																6792	(14,973)		
			Heavy																			6404
		3.5 (4.6)	Log/Agg																		6720	
			Heavy																			6328
		4.1 (5.4)	Log/Agg																		6298	
			Heavy																			5913
	Fusion	3.0 (3.9)	Log/Agg																	6690	(14,748)	
			Heavy																			6299
		3.5 (4.6)	Log/Agg																		6482	
			Heavy																			6097
		4.1 (5.4)	Log/Agg																		6076	
			Heavy																			5689
930M	Pin On	3.0 (3.9)	Log/Agg																7672	(16,913)		
			Heavy																			7281
		3.5 (4.6)	Log/Agg																		7241	
			Heavy																			6855
		4.1 (5.4)	Log/Agg																		7020	
			Heavy																			6636
	Fusion	3.5 (4.6)	Log/Agg																	7427	(16,373)	
			Heavy																			7043
		4.1 (5.4)	Log/Agg																		7011	
			Heavy																			6636
		5.0 (6.5)	Log/Agg																		6860	
			Heavy																			6481
938M	Pin On	4.1 (5.4)	Log/Agg																9588	(22,018)		
			Heavy																			9580
		5.0 (6.5)	Log/Agg																		8750	
			Heavy																			8384
		5.0 (6.5)	Standard																		7930	
			Standard																			8480
	Fusion	4.1 (5.4)	Log/Agg																	8635	(19,036)	
			Heavy																			8266
		5.0 (6.5)	Log/Agg																		8480	
			Heavy																			8112

Material density, fill factor, and counterweight options are key variables when choosing the appropriate size of the bucket. The long floor and open throat design of the Performance Series Buckets along with the aggressive rack angles of the optimized linkage will demonstrate fill factors greater than 100% ISO rated. Refer to the expected fill factor % per material type at the top of the table and find a matching counterweight and fill factor along the side for proper bucket sizing.

*Full compliance to ISO 14397-1 (2007) Sections 1 thru 6, which requires 2% verification between calculation and testing.

Bucket Selection Tables

High Dump Bucket Selection – High Lift

Material Type		Fill Factor %														Tip Load Full Turn*		
		115%	115%	115%	110%	105%	110%	525	570	615	660	705	750	795				
926M High Lift	Pin On	Counter-weight	kg/m ³	345	390	435	480	525	570	615	660	705	750	795	kg	lb		
		m ³	lb/yd ³	(581)	(657)	(733)	(809)	(885)	(960)	(1,036)	(1,112)	(1,188)	(1,264)	(1,340)				
926M High Lift	Pin On	Log/Agg	Not Available															
		Heavy									115%	110%	105%	100%		4736	(10,441)	
		Log/Agg	Not Available															
		Heavy								115%	110%	105%	100%			4655	(10,262)	
		Log/Agg	Not Available															
		Heavy				115%	110%	105%	100%								4272	(9,418)
	Fusion	Log/Agg	Not Available															
		Heavy										115%	110%	105%	100%		4584	(10,105)
		Log/Agg	Not Available															
		Heavy								115%	110%	105%	100%			4424	(9,753)	
		Log/Agg	Not Available															
		Heavy				115%	110%	105%	100%								4043	(8,912)
930M High Lift	Pin On	Log/Agg	Not Available															
		Heavy									115%	110%	105%	100%		5110	(11,265)	
		Standard									115%	110%	105%	100%		4746	(10,463)	
		Log/Agg	Not Available															
		Heavy					115%	110%	105%	100%						4723	(10,412)	
		Standard				115%	110%	105%	100%								4362	(9,617)
	Fusion	Log/Agg	Not Available															
		Heavy										115%	110%	105%	100%		4560	(10,053)
		Standard				115%	110%	105%	100%								4200	(9,259)
		Log/Agg	Not Available															
		Heavy										115%	110%	105%	100%		4872	(10,740)
		Standard				115%	110%	105%	100%								4494	(9,906)
938M High Lift	Pin On	Log/Agg	Not Available															
		Heavy	Not Available															
		Standard										115%	110%	105%	100%		6412	(14,136)
		Log/Agg	Not Available															
		Heavy	Not Available															
		Standard				115%	110%	105%	100%								5700	(12,566)
	Fusion	Log/Agg	Not Available															
		Heavy	Not Available															
		Standard										115%	110%	105%	100%		5527	(12,184)
		Log/Agg	Not Available															
		Heavy	Not Available															
		Standard				115%	110%	105%	100%								5390	(11,882)

Material density, fill factor, and counterweight options are key variables when choosing the appropriate size of the bucket. The long floor and open throat design of the Performance Series Buckets along with the aggressive rack angles of the optimized linkage will demonstrate fill factors greater than 100% ISO rated. Refer to the expected fill factor % per material type at the top of the table and find a matching counterweight and fill factor along the side for proper bucket sizing.

*Full compliance to ISO 14397-1 (2007) Sections 1 thru 6, which requires 2% verification between calculation and testing.

Supplemental Specifications

Optional Equipment

	926M				930M				938M			
	Operating weight		Tipping load – full turn		Operating weight		Tipping load – full turn		Operating weight		Tipping load – full turn	
	kg	lb	kg	lb	kg	lb	kg	lb	kg	lb	kg	lb
Change with options removed:												
Heavy counterweight	N/A	N/A	N/A	N/A	-320	-705	-502	-1,107	-320	-705	-494	-1,089
Guard, crankcase	-11	-23	-16	-34	-11	-23	-13	-29	-11	-24	-17	-36
Guard, power train lower	-77	-170	-77	-168	-77	-170	-69	-151	-68	-150	-67	-146
Guard, driveshaft	-44	-96	-12	-26	-44	-96	-12	-26	-45	-100	-12	-27
Secondary steer	-69	-152	-75	-165	-69	-152	-73	-160	-69	-152	-74	-163
Ride control	-49	-108	-27	-59	-49	-108	-26	-57	-49	-108	-27	-59
Change with options added:												
Logger/Aggregate counterweight	+298	+656	+417	+919	+298	+656	+415	+914	+299	+659	+402	+886
Guard, front window	+34	+74	+17	+37	+34	+74	+18	+39	+34	+74	+18	+39
Guard, rear waste gate	N/A	N/A	N/A	N/A	+264	+582	+456	+1,005	+284	+626	+478	+1,053
Guard, power train side	+11	+24	+10	+22	+11	+24	+9	+19	+11	+24	+10	+22
Cold start package	+54	+119	+104	+229	+54	+119	+74	+163	+54	+119	+101	+222
Roading fenders	+18	+39	+28	+61	+18	+39	+24	+52	+18	+39	+28	+61

Tire Options



	926M				930M				938M			
	550/65 R25		17.5 R25 (L-3)		600/65 R25		20.5R25 (L-5)		23.5R25 R25*		Flexport**	
	mm	in	mm	in	mm	in	mm	in	mm	in	mm	in
Change with tire option as compared to 20.5R25 L3 tire												
Vertical heights	-70	-2.8"	-65	-2.6"	-15	-0.6"	+35	+1.4"	65	-2.6"	+59	+2.3"
Reach: bucket at 45°	+43	+1.7"	+73	+2.9"	+29	+1.1"	-21	-0.8"	-63	-2.5"	-23	-0.9"
Width: Over tires	+10	+0.4"	-69	-2.7"	+98	+3.9"	0	0"	+38	+1.5"	-12	-0.5"
Turning radius: Outside of tires	+0	+0"	-45	-1.8"	+42	+1.7"	+1	0"	+14	+0.6"	+23	+0.9"
	kg	lb	kg	lb	kg	lb	kg	lb	kg	lb	kg	lb
Tipping load – straight	-83	-182	-212	-466	+9	+19	+444	+978	+486	+1,071	+1564	+3,447
Tipping load – full turn	-72	-157	-183	-403	+8	+17	+384	+846	+421	+927	+1352	+2,979
Operating weight	-126	-277	-322	-709	+14	+30	+678	+1,494	+748	+1,648	+2405	+5,300

*938M compatible with standard counterweight for general construction and heavy counterweight for Aggregate or Forest Handlers.

**938M compatible with standard counterweight (Flexport) only.

Supplemental Specifications

Ground Engagement Options

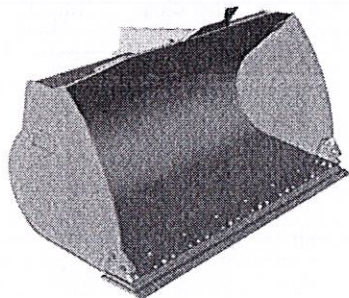

Bolt-on Cutting Edge

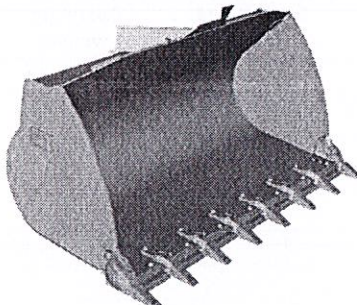

Long Teeth and Segments

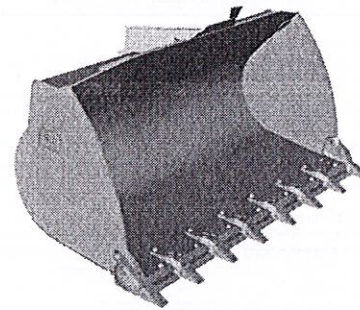

Short Teeth and Segments

Change with Ground Engagement option compared to Bolt-on Cutting Edge	926M				930M				938M			
	Long Teeth and Segments		Short Teeth and Segments		Long Teeth and Segments		Short Teeth and Segments		Long Teeth and Segments		Short Teeth and Segments	
	mm	in	mm	in	mm	in	mm	in	mm	in	mm	in
Dig depth	+12	+0.5"	+5	+0.2"	+11	+0.4"	+5	+0.2"	+11	+0.4"	+5	+0.2"
Length: overall	+146	+5.7"	+121	+4.8"	+146	+5.7"	+121	+4.8"	+146	+5.7"	+121	+4.8"
Dump clearance	-103	-4.1"	-82	-3.2"	-104	-4.1"	-83	-3.3"	-105	-4.1"	-84	-3.3"
Reach	+104	+4.1"	+89	+3.5"	+103	+4.1"	+88	+3.5"	+102	+4"	+87	+3.4"
	kg	lb	kg	lb	kg	lb	kg	lb	kg	lb	kg	lb
Tipping Load – straight	-148	-325	-142	-311	-150	-329	-143	-315	-138	-305	-132	-291
Tipping Load – full turn	-145	-318	-139	-305	-146	-322	-140	-309	-136	-298	-130	-285
Breakout force	-121	-266	-115	-254	-121	-266	-115	-254	-112	-245	-106	-234
Operating weight	+120	+264	+116	+255	+120	+264	+116	+255	+111	+244	+106	+233

926M, 930M, 938M Standard and Optional Equipment

Standard Equipment

Standard equipment may vary. Consult your Cat dealer for details.

POWER TRAIN

- Axle seal guards
- Auto idle shut down feature
- Cat C7.1 ACERT engine
 - Power Modes (Standard and Performance)
 - Power by Range (High Power in Range 4)
 - Turbocharged and aftercooled
 - Diesel particulate filter (Fit for Life)
- Coolant protection to -34° C (-29° F)
- Differential lock in front axle
- Dry type air cleaner
- Enclosed wet disc full hydraulic brakes
- Fuel priming pump, automatic
- Fuel water separator
- Hydraulically driven demand cooling fan
- Intelligent hydrostatic transmission
 - Power train modes
 - Directional Shift Aggressiveness
 - Rimpull control, adjust wheel torque
 - Creeper control, adjust ground speed
- Lubed for life driveshafts
- Parking brake, electric
- Wide spaced 6 fins per inch cooling package
- S-O-SSM sampling ports
- Throttle lock and maximum speed limiter

HYDRAULICS

- Automatic lift, lower and tilt kickouts
- Bucket and Fork Modes, adjustable in-cab
- Cylinder damping at kickout and end stops
- Fine Mode control in Fork Mode
- Hydraulic Response setting
- Load sensing hydraulics and steering
- Seat-mounted hydraulic joystick controls

ELECTRICAL

- Alternator, 115-amp, heavy duty
- 12V power supply in cab (2)
- Batteries, 1,000 CCA (2) 24 volt system
- Back-up alarm
- Emergency shutdown switch
- Heavy duty gear reduction starter
- Product Link PRO with subscription
- Remote jump start post
- Resettable critical function breakers

OPERATOR ENVIRONMENT

- 75 mm (3 in) retractable seat belt, with audible alarm and indicator
- Automatic temperature control
- Cab, enclosed and pressurized
- Cup holders
- External heated mirrors with lower parabolic
- Ground level cab door release

- Gauges
 - Digital hour, odometer, tachometer, ground speed and direction indicator
 - Engine coolant temperature gauge
 - Fuel and Diesel Exhaust Fluid level
 - Hydraulic oil temperature gauge
- Hydraulic control lockout
- Interior cab lighting, door and dome
- Interior rearview mirrors (2)
- Lunch box storage
- Operator warning system indicators
- Radio ready speakers
- Rear window defrost, electric
- Seat-mounted controls, adjustable
- Sliding glass on the side windows
- Column mounted multi function control – lights, wipers, turn signal
- Suspension seat, fabric
- Tilt and telescopic steering wheel
- Wet arm wiper/washer, front and rear

OTHER STANDARD EQUIPMENT

- Large-access enclosure doors
- Parallel lift loader linkage
- Recovery hitch with pin
- Remote mounted lubrication points
- Lockable compartments and enclosures

Optional Equipment

Optional equipment may vary. Consult your Cat dealer for details.

- Antifreeze/coolant, extended-life
- Auto lube, integrated in secondary display
- Auxiliary flow, third and fourth function
- Axles, differential, limited slip, rear
- Beacon light, strobe
- Cab, deluxe (standard in Europe):
 - Automatic blower control
 - Electrically adjustable heated mirrors (2)
 - LED interior lighting
 - Secondary display to adjust settings
- Ride control adjustable speed activation
- Preventative maintenance reminders
- Integrated help function (26 languages)
 - Sunscreen, front and rear
- Camera, rearview (standard in Europe)
- Cold start package:
 - Ether starting aid, block heater and additional batteries, 1,000 CCA (4 total)
- Counterweight, (heavy and logger)
- Coupler, (Fusion and ISO 23727)
- Debris packages (low, medium, high)
- Fenders (extended cover and full coverage)
- Guards
 - Power train, (lower, side, driveshaft and crankcase)
 - Windshield and lights
 - Cylinders, tilt and steering
 - Rear radiator, heavy duty
- Linkage, high lift
- Lights, auxiliary, halogen or LED with engine compartment lights
- Object Detection
- Radio packages:
 - Radio ready with Bluetooth
 - Radio, AM/FM with Bluetooth and clock
 - Radio, AM/FM with CD player deluxe, weatherband, Bluetooth and clock
- Seats:
 - Deluxe seat – fully adjustable fabric air suspension seat with mid seat backrest
 - Premium seat – fully adjustable leather and fabric air suspension with high backrest and air lumbar support. Heated and cooled bottom cushion and backrest.
- Steering:
 - Dual mode and Secondary
- Tires:
 - Bias ply, 17.5, 20.5-25, Skidder
 - Radial, 17.5, 20.5, 23.5, 550/65, 600/65, 650/65 R25
 - Flexport, 620/65, 750/65 Agriculture
- Work tools

For more complete information on Cat products, dealer services, and industry solutions, visit us on the web at www.cat.com

AEHQ7475 (06-2015)

© 2015 Caterpillar
All rights reserved

Materials and specifications are subject to change without notice. Featured machines in photos may include additional equipment. See your Cat dealer for available options.

CAT, CATERPILLAR, SAFETY.CAT.COM, their respective logos, "Caterpillar Yellow" and the "Power Edge" trade dress, as well as corporate and product identity used herein, are trademarks of Caterpillar and may not be used without permission.

VisionLink is a trademark of Trimble Navigation Limited, registered in the United States and in other countries.



938 BID SPEC

938 WHEEL LOADER GOVBIDSPEC.COM

BID SPECIFICATION FOR 938 OR EQUIVALENT

BASIC SPECIFICATIONS

Y ___ N ___	Engine net power according to ISO 9249 shall be at least 180 hp (134 kW).
Y ___ N ___	Engine gross power according to SAE J1995 shall be at least 197 hp (147 kW).
Y ___ N ___	Basic operating weight shall be no less than 35,273 lb (16,004 kg). Weight shall be based on standard machine configuration (with 20.5-R25 L2 tires and 3.25 cubic yard general purpose quick coupler bucket with bolt-on edges).
Y ___ N ___	Machine height to top of ROPS shall be 11'0" (3356 mm).
Y ___ N ___	Machine height to top of hood shall be 7'11" (2415 mm).
Y ___ N ___	Ground clearance with 20.5-R25 tires shall be 1'3" (397 mm).
Y ___ N ___	Machine wheelbase shall be 9'11" (3020 mm).
Y ___ N ___	B-Pin maximum height shall be at least 12'10" (3933 mm).
Y ___ N ___	Maximum bucket capacity shall be at least 3.66 cubic yards (3.0 cubic meters).

ENGINE

Y ___ N ___	Engine shall be EPA Tier III compliant.
Y ___ N ___	Engine shall be fully equipped, six cylinder, four stroke diesel type with all necessary operating accessories.
Y ___ N ___	Engine shall be configured to provide constant net horsepower at full parasitic load.
Y ___ N ___	Engine electronic control modules and sensors shall be completely sealed against moisture and dust.
Y ___ N ___	Deutsche connectors and electrical wire braiding shall ensure that electrical connections resist corrosion and premature wear.
Y ___ N ___	An electrical disconnect switch shall be standard.
Y ___ N ___	Engine shall have a total displacement of no less than 402.8 cubic inches (6.6 liters).
Y ___ N ___	Engine bore shall be 4.1" (105 mm) and stroke shall be 5" (127 mm).
Y ___ N ___	Net Peak torque at 1400 rpm shall be 620 ft-lb (840 N-m).
Y ___ N ___	Engine shall have four idle control settings to help maximize fuel efficiency: hibernate allows idle speed to drop after a preset time, work provides flexibility in working engine idle speeds, warm-up helps keep the engine from dropping below a set temperature in cold conditions, and low voltage mode prevents battery drain due to high electrical loads from attachments.
Y ___ N ___	Machine shall have a 24-volt starting and charging system with a minimum 65-amp alternator.
Y ___ N ___	Electric fuel priming pump shall be standard.
Y ___ N ___	A heavy-duty electric starter shall be standard.
Y ___ N ___	Machine shall have a 24-volt starting receptacle as standard.
Y ___ N ___	Cooling system shall be isolated from the engine compartment by a non-metallic shield.
Y ___ N ___	Standard radiator shall be a square-wave core design with 6-fins-per-inch.
Y X N ___	Variable speed fan shall draw air in from the rear of the machine and exhaust out the sides and top of the hood.
Y X N ___	Engine shall be enclosed in a non-metallic, one-piece tilting hood that allows complete and unrestricted access to the engine and related components.
Y ___ N ___	Wheel loader can be equipped with an engine coolant heater to be powered by a 120 V external electric power source.
Y ___ N ___	Engine shall have available an externally mounted pre-cleaner.

938 BID SPEC

TRANSMISSION/POWERTRAIN	
Y <input checked="" type="checkbox"/> N	Transmission and other major powertrain components, such as the axles, shall be designed and manufactured by the equipment manufacturer.
Y <input checked="" type="checkbox"/> N	Automatic transmission shall be of countershaft powershift design.
Y <input checked="" type="checkbox"/> N	Transmission shall be electronically controlled for smooth clutch modulation.
Y <input checked="" type="checkbox"/> N	Machine shall have a fuel economy mode that allows the transmission to upshift at lower RPM's.
Y <input type="checkbox"/> N	Machine shall four speeds forward with a maximum of 26.8 mph (43.2 km/h) and three speeds reverse with a minimum of 15.8 mph (25.5 km/h).
Y <input type="checkbox"/> N	Machine shall have an electronically controlled, variable on-demand speed fan.
Y <input type="checkbox"/> N	Machine shall be equipped with a bottom crankcase and fuel tank guards.
Y <input checked="" type="checkbox"/> N	Transmission shall have a cooler bypass valve enabling faster warm-up in low ambient conditions- providing smoother shifts in cold weather.
Y <input checked="" type="checkbox"/> N	Transmission shall automatically select gears above first. The operator shall be able to select the highest gear to which the transmission will automatically shift.
Y <input checked="" type="checkbox"/> N	Machine shall have a transmission gear kick-down button capable of making fourth to third, third to second and second to first gear shifts in automatic mode.
Y <input checked="" type="checkbox"/> N	Transmission shall offer full manual shifting for first, second, third and fourth gear.
Y <input checked="" type="checkbox"/> N	Final drives shall be of planetary design and outward mounted.
Y <input checked="" type="checkbox"/> N	Control throttle shifting shall regulate engine speed during high-energy directional changes for smoother shifting and longer component life.
Y <input checked="" type="checkbox"/> N	Machine shall provide a transmission neutralizer that also incorporates downshifting logic and is adjustable through the machine graphical display.
STEERING	
Y <input type="checkbox"/> N	Machine shall have center-point articulation with an articulation angle of at least $\pm 40^\circ$.
Y <input checked="" type="checkbox"/> N	Machine shall have full hydraulic load sensing steering piston pump.
Y <input type="checkbox"/> N	Machine turning diameter shall not exceed 39' 2" (11,946 mm) as measured at the outside tip of the manufacturer's general purpose bucket.
BRAKES	
Y <input type="checkbox"/> N	Machine shall have oil cooled 2 disc-type per wheel, adjustment-free service brakes which are outboard mounted and sealed from water, mud and dust.
Y <input checked="" type="checkbox"/> N	Service brake actuation shall be of independent front and rear hydraulic circuits providing effective braking in the event of partial system malfunction.
Y <input checked="" type="checkbox"/> N	Service brakes shall have a sealed brake wear indicator with an external port that allows a visual brake wear pin inspection.
HYDRAULIC SYSTEM	
Y <input type="checkbox"/> N	Machine shall feature load-sensing hydraulics to automatically adjust to operating conditions and provide only hydraulic flow required by the implement.
Y <input type="checkbox"/> N	Hydraulic pump output for the bucket/work tool system shall be 77.9 gal/min (295 L/min).
Y <input type="checkbox"/> N	Hydraulic system shall be filtered and completely sealed.
Y <input checked="" type="checkbox"/> N	Hydraulic pressure taps shall be provided for checking pressure in the hydraulic implement and steering systems.
Y <input type="checkbox"/> N	A third hydraulic valve with control lever and hydraulic lines to the end of the lift arms for operating auxiliary equipment shall be available.
Y <input type="checkbox"/> N	Hydraulic cycle time shall be no more than 10.4 seconds.
Y <input type="checkbox"/> N	Loader shall have automatic bucket positioner and lift kick-out. Bucket positioner and lift kick-out shall be adjustable to different bucket angles and lift heights, respectively.

938 BID SPEC

Y ___ N ___	Available joystick with integrated F-N-R switch shall be available.
Y <input checked="" type="checkbox"/> N	Locking devices shall be capable of temporarily disabling the levers which control the hydraulics.
AXLES	
Y ___ N ___	Wheel loader shall have an axle oil cooler available for applications where extreme braking or operating needs heat axle oil quickly.
Y ___ N ___	Axles shall be axle oil cooler ready with pre-dilled and tapped axle housings along with pre-routed internal steel lines and mounting hardware.
Y ___ N ___	Wheel loader shall have a front hydraulic locking differential
Y <input checked="" type="checkbox"/> N	Wheel loader shall have available an automatic hydraulic locking front/rear differentials.
Y ___ N ___	Wheel loader shall have standard front and rear axle temperature monitoring.
Y ___ N ___	Rear axle shall not have less than a 24-degree total oscillation.
OPERATORS STATION	
Y ___ N ___	Integral ROPS and sound suppressed cab shall be standard.
Y ___ N ___	Cab shall include a heater and defroster.
Y ___ N ___	Cab shall not have any curved glass.
Y <input checked="" type="checkbox"/> N	Cab shall have pressurized and filtered air circulation system.
Y ___ N ___	Cab shall be mounted on the rear frame of the machine.
Y <input checked="" type="checkbox"/> N	Machine shall be equipped with a multilevel warning system, which shall signal machine and component malfunctions. System should differentiate between major and minor malfunctions. Warning system shall record occurrences of periodic malfunctions.
Y ___ N ___	Machine shall be equipped with a graphical display system (Messenger) that provides onboard machine diagnostics, machine system parameters, settings, and operator specific profiles.
Y ___ N ___	Single lever joystick control of implement levers with integrated switch for transmission forward-neutral-reverse shift capabilities shall be available.
Y <input checked="" type="checkbox"/> N	A single control lever mounted on the steering column shall actuate directional and gear changes.
Y ___ N ___	Machine bucket/work tool controls shall have available a two-lever design.
Y <input checked="" type="checkbox"/> N	Transmission shall have a software feature that allows operator to vary shift points by adjusting value in the graphical machine display.
Y <input checked="" type="checkbox"/> N	Steering wheel, gauge panel, and transmission control lever shall be adjustable as a single unit.
Y ___ N ___	Operator's seat shall be a cloth-covered suspension-type with adjustments for height, weight, fore/aft, and suspension dampening.
Y ___ N ___	Seat shall include adjustable armrests on left and right.
Y ___ N ___	Cab shall be pre-wired with electric voltage converter, speakers, and antenna for installation of an entertainment radio.
Y ___ N ___	Cab shall be equipped with a wiring harness having a harness connector to simplify servicing by avoiding the need to cut electrical wires when removing the cab.
Y ___ N ___	Operator's compartment can include a retractable 2" (51 mm) wide seat belt.
Y ___ N ___	Cab shall have windshield wipers with an in-the-blade washer delivery system for the front and rear windows. Front wipers shall have intermittent capability.
Y ___ N ___	Cab shall have internally mounted rear-view mirrors.
Y ___ N ___	Machine shall have floor-mounted pedals for greater operator comfort.
Y ___ N ___	Machine shall have front fenders and may be equipped with rear platform extensions.

938 BID SPEC

Y ___ N ___	Machine shall have a back-up alarm.
Y ___ N ___	Machine shall have sloped hood for improved rearward visibility and improved work environment safety.
Y ___ N ___	Machine shall have audible alarm and warning light to alert the operator if the service brake actuating pressure drops below a safe operating level. If service brake actuating pressure drops below a safe operating level, the secondary brake shall be applied automatically.
Y ___ N ___	Machine shall have two brake pedals. Left brake pedal to switch between a brake/neutralizer or brake only function through the machine graphical display.
Y ___ N ___	Directional signals shall be standard.
Y ___ N ___	Machine shall be available with an outside toolbox.
Y ___ N ___	Machine shall be available with rear vision camera with 7" in cab monitor.
LOADER LINKAGE	
Y ___ N ___	Loader linkage shall be parallel lift type with high breakout force.
Y ___ N ___	Loader bucket tilt lever shall be of a cast design for durability and strength.
Y ___ N ___	Full turn static tipping load shall be at least 21,179 lb (9,610 kg).
Y ___ N ___	Breakout force shall not be less than 30,239 lb (134.6 kN).
Y ___ N ___	Dump clearance at full lift and 45° discharge shall be a minimum of 9'0" (2733 mm) when equipped with a 3.25 cubic yard (2.5 cubic meter) quick coupler bucket with bolt-on cutting edge.
Y ___ N ___	Minimum bucket rack-back angle shall be at least 50 degrees in carry position.
WORK TOOL OPTIONS	
Y ___ N ___	Loader bucket shall have bolt-on bottom wear plates.
SERVICEABILITY	
Y ___ N ___	Oil sampling ports shall be standard for quick and clean access to various machine oils (such as hydraulic, transmission and engine oil).
Y ___ N ___	S.O.S sampling ports shall be accessible from ground level
Y ___ N ___	Sight gauges for the transmission oil, hydraulic oil and radiator coolant shall be easy to see and will eliminate the risk of contaminants entering the system during daily checks.
Y ___ N ___	Machine shall have maintenance-free batteries located in a built-in battery box.
Y ___ N ___	Machine shall have electrically actuated fuel priming pump to simplify fuel filter changes.
Y ___ N ___	Grill, a/c condenser and hydraulic oil cooler should swing open for easy access.
Y ___ N ___	Powertrain shall use a vertically mounted filter to minimize oil spillage during filter change.
Y ___ N ___	Articulation joint shall have a single mechanical locking device to prevent frame articulation while servicing or transporting machine.
Y ___ N ___	Transmission oil and hydraulic filters shall be located behind the hinged, right-side access platform in an enclosed compartment. The hydraulic oil tank shall be drainable from this location.
Y ___ N ___	Standard Ecology Drains on engine, transmission, and hydraulic oil shall allow clean draining of fluids with minimal spillage.
MINIMUM SERVICE FILL CAPACITIES	
Y ___ N ___	Cooling system shall have a capacity of 9.5 gal (36 L).
Y ___ N ___	Fuel tank shall have a capacity of 65.3 gal (247 L).
Y ___ N ___	Transmission shall have a capacity of 11.4 gal (43 L).

938 BID SPEC

Y___ N___	Crankcase shall have a capacity of 4.6 gal (17.4 L).
Y___ N___	Hydraulic System (including tank) shall have a capacity of 23.5 gal (89L).
OWNING & OPERATING COSTS	
Y___ N___	Engine shall have a recommended 500 hour oil change interval for lower operating maintenance costs
Y___ N___	Extended life coolant shall be standard for lower service intervals and reduced maintenance costs.
ADDITIONAL FEATURES	
Y___ N___	Wheel loader shall have an automatic bucket suspension system available that uses an accumulator in the lift arm circuit to reduce material spillage when traveling over rough or uneven surfaces.
Y___ N___	The distance from the bottom of the upper hitch pin to the top of the lower hitch pin shall not be less than 23" (584 mm) for torsion stress distribution and better hitch bearing durability.
<input checked="" type="checkbox"/> Y <input type="checkbox"/> N	Articulation joint shall have double tapered roller bearings in the upper and lower hitch for extended life.
<input checked="" type="checkbox"/> Y <input type="checkbox"/> N	Machine shall be equipped with a rear retrieval connection.
<input checked="" type="checkbox"/> Y <input type="checkbox"/> N	Machine shall be equipped with a standard counterweight 2,959 lb (1,342 kg).
<input checked="" type="checkbox"/> Y <input type="checkbox"/> N	Machine shall have lifting/tie down eyes for transportation.
Y___ N___	Machine shall have available a machine electronic security system that can lock out unauthorized usage of the machine.
Y___ N___	Machine should have standard a satellite-based system available that allows real-time retrieval of machine information and location.
<p>Bid specs are intended for use by North American buyers only and are subject to change. Model configuration may change depending on country of use. Please contact your local Caterpillar dealer for the most up-to-date specifications for your area.</p>	

Effective with sales to the first user on or after June 1, 2015

CATERPILLAR LIMITED WARRANTY

For Selected Machine Models Designated by Caterpillar with 12 Month/Unlimited Hour Warranty

Worldwide

Caterpillar Inc. or any of its subsidiaries ("Caterpillar") warrants the following products sold by it to be free from defects in material and workmanship:

- New earthmoving, construction, material handling, forestry product, paving product, compact wheel loader, mini hydraulic excavator, skid steer loader, multi terrain loader, and compact track loader machines designated by Caterpillar as having 12-months/unlimited hour warranty. See your Cat® dealer for a complete listing of covered models.
- Attachments/work tools installed on such machines prior to delivery (unless covered by the Cat Work Tool warranty statement or another manufacturer's warranty). Hammer tool points and compacting plates used on hydraulic hammers are not warranted.

An additional warranty against breakage is applicable to certain Cat ground engaging tools. An additional warranty against wear is applicable to all landfill compactor tips when used in residential waste landfills. Refer to the applicable warranty statements for coverage detail.

This warranty does not apply to:

- Cat Batteries
- Mobil-trac belts, rubber tracks used on multi terrain loaders, compact track loaders, and mini hydraulic excavators
- Cat Work Tools
- Select models designated by Caterpillar that are sold in India and China

These products are covered by other Caterpillar warranties. This warranty is subject to the following:

Warranty Period

For new machines and work tools/attachments the warranty period is 12-months/unlimited hours, starting from date of delivery to the first user.

Note:

- For hydraulic line's quick connect/disconnect components sold on compact wheel loaders, mini hydraulic excavators, skid steer loaders, multi terrain loaders, and compact track loader machines, the warranty period is 50 hours starting from the date of delivery to the first user.
- For Draglines, Electric Rope Shovels, Hard Rock Movers, Hard Rock Feeders; the warranty period is not to exceed 24 months from shipment of the last major component from the Caterpillar place of manufacture.

Caterpillar Responsibilities

If a defect in material or workmanship is found during the warranty period, Caterpillar will, during normal working hours and at a place of business of a Cat dealer or other source approved by Caterpillar:

- Provide (at Caterpillar's choice) new, remanufactured, or Caterpillar approved repaired parts or assembled components needed to correct the defect.

Note: New, remanufactured, or Caterpillar approved replacement parts provided under the terms of this warranty are warranted for the remainder of the warranty period applicable to the product in which installed as if such parts were original components of that product. Items replaced under this warranty become the property of Caterpillar.

- Replace lubricating oil, filters, antifreeze, and other service items made unusable by the defect.
- Provide reasonable and customary labor needed to correct the defect.

User Responsibilities

The user is responsible for:

- Providing proof of delivery date to the first user.

- Labor costs, except as stated under "Caterpillar Responsibilities."
- Transportation costs, except as stated under "Caterpillar Responsibilities."
- Premium or overtime labor costs.
- Parts shipping charges in excess of those that are considered usual and customary.
- Local taxes, if applicable.
- Costs to investigate complaints, unless the problem is caused by a defect in Caterpillar material or workmanship.
- Giving timely notice of a warrantable failure and promptly making the product available for repair.
- Performance of the required maintenance (including use of proper fuel, oil, lubricants, and coolant) and items replaced due to normal wear and tear.
- Allowing Caterpillar access to all electronically stored data.

Limitations

Caterpillar is not responsible for:

- Failures resulting from any use or installation that Caterpillar judges improper.
- Failures resulting from attachments, accessory items, and parts not sold or approved by Caterpillar.
- Failures resulting from abuse, neglect, and/or improper storage or repair.
- Failures resulting from user's delay in making the product available after being notified of a potential product problem.
- Failures resulting from unauthorized repair or adjustments, and unauthorized fuel setting changes.

(Continued on the reverse side...)

This warranty covers every major component of the products. Claims under this warranty should be submitted to a place of business of a Cat dealer or other source approved by Caterpillar. For further information concerning either the location to submit claims or Caterpillar as the issuer of this warranty, write Caterpillar Inc., 100 N. E. Adams St., Peoria, IL USA 61629.

Caterpillar's obligations under this Limited Warranty are subject to, and shall not apply in contravention of, the laws, rules, regulations, directives, ordinances, orders, or statutes of the United States, or of any other applicable jurisdiction, without recourse or liability with respect to Caterpillar.

A) For products operating outside of Australia, Fiji, Nauru, New Caledonia, New Zealand, Papua New Guinea, the Solomon Islands, and Tahiti, the following is applicable:

NEITHER THE FOREGOING EXPRESS WARRANTY NOR ANY OTHER WARRANTY BY CATERPILLAR, EXPRESS OR IMPLIED, IS APPLICABLE TO ANY ITEM CATERPILLAR SELLS THAT IS WARRANTED DIRECTLY TO THE USER BY ITS MANUFACTURER.

THIS WARRANTY IS EXPRESSLY IN LIEU OF ANY OTHER WARRANTIES, EXPRESS OR IMPLIED, INCLUDING ANY WARRANTY OF MERCHANTABILITY OR FITNESS, FOR A PARTICULAR PURPOSE, EXCEPT CATERPILLAR EMISSION-RELATED COMPONENTS WARRANTY FOR NEW ENGINES, WHERE APPLICABLE. REMEDIES UNDER THIS WARRANTY ARE LIMITED TO THE PROVISION OF MATERIAL AND SERVICES, AS SPECIFIED HEREIN.

CATERPILLAR IS NOT RESPONSIBLE FOR INCIDENTAL OR CONSEQUENTIAL DAMAGES.

CATERPILLAR EXCLUDES ALL LIABILITY FOR OR ARISING FROM ANY NEGLIGENCE ON ITS PART OR ON THE PART OF ANY OF ITS EMPLOYEES, AGENTS, OR REPRESENTATIVES IN RESPECT OF THE MANUFACTURE OR SUPPLY OF GOODS OR THE PROVISION OF SERVICES RELATING TO THE GOODS.

IF OTHERWISE APPLICABLE, THE VIENNA CONVENTION ON CONTRACTS FOR THE INTERNATIONAL SALE OF GOODS IS EXCLUDED IN ITS ENTIRETY.

B) For products operating in Australia, Fiji, Nauru, New Caledonia, New Zealand, Papua New Guinea, the Solomon Islands, and Tahiti, the following is applicable:

THIS WARRANTY IS IN ADDITION TO WARRANTIES AND CONDITIONS IMPLIED BY STATUTE AND OTHER STATUTORY RIGHTS AND OBLIGATIONS THAT BY ANY APPLICABLE LAW CANNOT BE EXCLUDED, RESTRICTED OR MODIFIED ("MANDATORY RIGHTS"). ALL OTHER WARRANTIES OR CONDITIONS, EXPRESS OR IMPLIED (BY STATUTE OR OTHERWISE), ARE EXCLUDED, WITHOUT LIMITING THE FOREGOING PROVISIONS OF THIS PARAGRAPH, WHERE A PRODUCT IS SUPPLIED FOR BUSINESS PURPOSES. THE CONSUMER GUARANTEES UNDER THE CONSUMER GUARANTEES ACT 1993 (NZ) WILL NOT APPLY.

NEITHER THIS WARRANTY NOR ANY OTHER CONDITION OR WARRANTY BY CATERPILLAR, EXPRESS OR IMPLIED (SUBJECT ONLY TO THE MANDATORY RIGHTS), IS APPLICABLE TO ANY ITEM CATERPILLAR SELLS THAT IS WARRANTED DIRECTLY TO THE USER BY ITS MANUFACTURER.

IF THE MANDATORY RIGHTS MAKE CATERPILLAR LIABLE IN CONNECTION WITH SERVICES OR GOODS, THEN TO THE EXTENT PERMITTED UNDER THE MANDATORY RIGHTS, THAT LIABILITY SHALL BE LIMITED AT CATERPILLAR'S OPTION TO (a) IN THE CASE OF SERVICES, THE SUPPLY OF THE SERVICES AGAIN OR THE PAYMENT OF THE COST OF HAVING THE SERVICES SUPPLIED AGAIN AND (b) IN THE CASE OF GOODS, THE REPAIR OR REPLACEMENT OF THE GOODS, THE SUPPLY OF EQUIVALENT GOODS, THE PAYMENT OF THE COST OF SUCH REPAIR OR REPLACEMENT OR THE ACQUISITION OF EQUIVALENT GOODS.

CATERPILLAR EXCLUDES ALL LIABILITY FOR OR ARISING FROM ANY NEGLIGENCE ON ITS PART OR ON THE PART OF ANY OF ITS EMPLOYEES, AGENTS OR REPRESENTATIVES IN RESPECT OF THE MANUFACTURE OR SUPPLY OF GOODS OR THE PROVISION OF SERVICES RELATING TO THE GOODS.

SELF-5671

CATERPILLAR IS NOT LIABLE FOR INCIDENTAL OR CONSEQUENTIAL DAMAGES UNLESS IMPOSED UNDER MANDATORY RIGHTS. IF OTHERWISE APPLICABLE, THE VIENNA CONVENTION (CONTRACTS FOR THE INTERNATIONAL SALE OF GOODS) IS EXCLUDED IN ITS ENTIRETY.

C) For products supplied in Australia:

IF THE PRODUCTS TO WHICH THIS WARRANTY APPLIES ARE:

- I. PRODUCTS OF A KIND ORDINARILY ACQUIRED FOR PERSONAL, DOMESTIC OR HOUSEHOLD USE OR CONSUMPTION; OR
- II. PRODUCTS THAT COST AUD 40,000 OR LESS,

WHERE THOSE PRODUCTS WERE NOT ACQUIRED FOR THE PURPOSE OF RE-SUPPLY OR FOR THE PURPOSE OF USING THEM UP OR TRANSFORMING THEM IN THE COURSE OF PRODUCTION OR MANUFACTURE OR IN THE COURSE OF REPAIRING OTHER GOODS OR FIXTURES, THEN THIS SECTION C APPLIES.

THE FOLLOWING MANDATORY TEXT IS INCLUDED PURSUANT TO THE AUSTRALIAN CONSUMER LAW AND INCLUDES REFERENCES TO RIGHTS THE USER MAY HAVE AGAINST THE DIRECT SUPPLIER OF THE PRODUCTS: OUR GOODS COME WITH GUARANTEES THAT CANNOT BE EXCLUDED UNDER THE AUSTRALIAN CONSUMER LAW. YOU ARE ENTITLED TO A REPLACEMENT OR REFUND FOR A MAJOR FAILURE AND COMPENSATION FOR ANY OTHER REASONABLY FORESEEABLE LOSS OR DAMAGE. YOU ARE ALSO ENTITLED TO HAVE THE GOODS REPAIRED OR REPLACED IF THE GOODS FAIL TO BE OF ACCEPTABLE QUALITY AND THE FAILURE DOES NOT AMOUNT TO A MAJOR FAILURE. THE INCLUSION OF THIS TEXT DOES NOT CONSTITUTE ANY REPRESENTATION OR ACCEPTANCE BY CATERPILLAR OF LIABILITY TO THE USER OR ANY OTHER PERSON IN ADDITION TO THAT WHICH CATERPILLAR MAY HAVE UNDER THE AUSTRALIAN CONSUMER LAW.

TO THE EXTENT THE PRODUCTS FALL WITHIN THIS SECTION C BUT ARE NOT OF A KIND ORDINARILY ACQUIRED FOR PERSONAL, DOMESTIC OR HOUSEHOLD USE OR CONSUMPTION, CATERPILLAR LIMITS ITS LIABILITY TO THE EXTENT IT IS PERMITTED TO DO SO UNDER THE AUSTRALIAN CONSUMER LAW TO, AT ITS OPTION, THE REPAIR OR REPLACEMENT OF THE PRODUCTS, THE SUPPLY OF EQUIVALENT PRODUCTS, OR THE PAYMENT OF THE COST OF SUCH REPAIR OR REPLACEMENT OR THE ACQUISITION OF EQUIVALENT PRODUCTS.

THE WARRANTY SET OUT IN THIS DOCUMENT IS GIVEN BY CATERPILLAR INC. OR ANY OF ITS SUBSIDIARIES, 100 N. E. ADAMS ST. PEORIA, IL USA 61629, TELEPHONE 1 309 675 1000. THE USER IS RESPONSIBLE FOR ALL COSTS ASSOCIATED WITH MAKING A CLAIM UNDER THE WARRANTY SET OUT IN THIS DOCUMENT, EXCEPT AS EXPRESSLY STATED OTHERWISE IN THIS DOCUMENT, AND THE USER IS REFERRED TO THE BALANCE OF THE DOCUMENT TERMS CONCERNING CLAIM PROCEDURES, CATERPILLAR RESPONSIBILITIES AND USER RESPONSIBILITIES.

TO THE EXTENT PERMISSIBLE BY LAW, THE TERMS SET OUT IN THE REMAINDER OF THIS WARRANTY DOCUMENT (INCLUDING SECTION B) CONTINUE TO APPLY TO PRODUCTS TO WHICH THIS SECTION C APPLIES.

©2014 Caterpillar. All Rights Reserved. CAT, CATERPILLAR, their respective logos, "Caterpillar Yellow," the "Power Edge" trade dress as well as corporate and product identity used herein, are trademarks of Caterpillar and may not be used without permission.

CONTROL YOUR COSTS MINIMIZE YOUR RISKS

This plan safeguards your investments in new, used and rebuilt machines beyond the standard warranty period. It includes all parts and labor to protect you against failures caused by defects in materials and workmanship. With the Powertrain Equipment Protection Plan, you can increase the predictability of service and maintenance costs—and reduce unplanned downtime.

WHAT WE DO

- Perform necessary inspections to confirm eligibility
- Install parts approved by Caterpillar on covered repairs
- Validate your enrollment in the program

WHAT YOU DO

- Operate equipment according to the Cat Operation & Maintenance Manual (OMM)
- Have recommended preventive maintenance performed at intervals specified in the OMM
- Upon request, provide proof of preventive maintenance compliance (receipts, copies of work orders, invoices)
- Promptly provide the machine for repair in the event of a covered failure

EXCLUSIONS

If a component is not listed, it may not be included in the plan. Other exclusions include:

- > Improper or abusive use of the machine
- > Lubricating oil, antifreeze, filters, consumables and other maintenance items replaced during the covered component repair, unless such items are rendered unusable by a covered component failure
- > Failures caused by normal wear-out
- > Freight charges for parts shipments
- > Travel time and mileage involved in getting to a job site
- > Hauling costs and / or retrieval costs
- > Overtime labor costs
- > Repair costs resulting from the failure of any non-covered components
- > Downtime loss
- > Equipment rental charges
- > Any incidental / consequential damages or costs incurred as a result of a covered component failure.
- > Modifications unless approved by Caterpillar

Examples of covered and excluded components or items are listed here. The actual dealer contract will govern. For a complete list of included components and more information on Cat Equipment Protection Plans, contact your local Cat dealer.

Camshaft & Camshaft Bearings

Engine - Internal Components

Oil Cooler

Manifolds

Fan Motor

Water Pump

Fuel Injection Pumps

Injectors

Lift / Transfer Pump

Senders / Solenoids / Sensors

Thermostat

Flywheel & Torque Converter

Engine Oil Filter Mount

Turbocharger

AC Compressor / Condenser

Electronic Control Modules

Oil Hoses / Lines (non-hydrostatic)

Cylinder Block

Piston

Piston Rings

Piston & Connecting Rod

Crankshaft, Main Bearings & Rod Bearings

Timing / Accessory Gears

Timing Chain / Belt

Inlet / Exhaust Valve

Valve Cover & Base

Valve Spring & Guide

Rocker Arm

Rocker Shaft Assembly

Push Rod

Balancer

Fuel Pump / Governor Drive

Oil Pump

Oil Pan Group

Fan & Fan Drive

Transmission

Transmissions

Hydraulic Controls

Transmission Oil Filter-Base

Transmission Gears

Final Drives/Planetary

Drive Shafts

Transfer Case

Hydrostatic Pumps &

Drive Motors

Linkage / lines Connected to

Hystat Pump

Drive (pilot / eh) Control Valves

Bevel and Transfer Case

Drive Controls

Axles

Axle Seals

Final Drive & Wheel

Final Drive Case / Bore

Final Drive Chain

Final Drive Gears

Axle Shaft

Drive Axle Oil Pump

Steering /

Steering Clutch

Steering Clutch & Brake Control Valve

Hydraulic Systems

Hydraulic Oil Coolers



Employment Eligibility Verification

Welcome
Terena Norton

User ID
TMOR9402

Last Login
09:22 AM - 01/06/2012

Log Out

Click any for help

- Home
- My Cases
- New Case
- View Cases
- Search Cases
- My Profile
- Edit Profile
- Change Password
- Change Security Questions
- My Company
- Edit Company Profile
- Add New User
- View Existing Users
- Close Company Account
- My Reports
- View Reports
- My Resources
- View Essential Resources
- Take Tutorial
- View User Manual
- Contact Us

Company Information

Company Name: Thompson Tractor Co., Inc.

[View / Edit](#)

Company ID Number: 47130

Doing Business As (DBA) Name:

DUNS Number:

Physical Location:

Address 1: 2401 Pinson Highway

Address 2:

City: Birmingham

State: AL

Zip Code: 35217

County: JEFFERSON

Mailing Address:

Address 1: P O. Box 10367

Address 2:

City: Birmingham

State: AL

Zip Code: 35202-0367

Additional Information:

Employer Identification Number: 630377478

Total Number of Employees: 1,000 to 2,499

Parent Organization:

Administrator:

Organization Designation:

Employer Category:

NAICS Code: 423 - MERCHANT WHOLESALERS, DURABLE GOODS

[View / Edit](#)

Total Hiring Sites: 40

[View / Edit](#)

Total Points of Contact: 3

[View / Edit](#)

[View MOU](#)

Company ID Number: 47130

the Employer issues a tentative nonconfirmation based upon a photo non-match. The Employer will determine whether the employee contests the tentative nonconfirmation as soon as possible after the Employer receives it.

4. If the employee contests a tentative nonconfirmation issued by DHS, the Employer will provide the employee with a referral letter and instruct the employee to contact the Department through its toll-free hotline within 8 Federal Government work days.

5. If the employee contests a tentative nonconfirmation based upon a photo non-match, the Employer will provide the employee with a referral letter to DHS. DHS will electronically transmit the result of the referral to the Employer within 10 Federal Government work days of the referral unless it determines that more than 10 days is necessary.

6. The Employer agrees that if an employee contests a tentative nonconfirmation based upon a photo non-match, the Employer will send a copy of the employee's Form I-551 or Form I-766 to DHS for review by:

- Scanning and uploading the document, or
- Sending a photocopy of the document by an express mail account (furnished and paid for by DHS).

7. The Employer understands that if it cannot determine whether there is a photo match/non-match, the Employer is required to forward the employee's documentation to DHS by scanning and uploading, or by sending the document as described in the preceding paragraph, and resolving the case as specified by the Immigration Services Verifier at DHS who will determine the photo match or non-match.

ARTICLE IV

SERVICE PROVISIONS

The SSA and DHS will not charge the Employer for verification services performed under this MOU. The Employer is responsible for providing equipment needed to make inquiries. To access the E-Verify System, an Employer will need a personal computer with Internet access.

ARTICLE V

PARTIES

This MOU is effective upon the signature of all parties, and shall continue in effect for as long as the SSA and DHS conduct the E-Verify program unless modified in writing by the mutual consent of all parties, or terminated by any party upon 30 days prior written notice to the others. Any and all system enhancements to the E-Verify program by DHS or SSA, including but not limited to the E-Verify checking against additional data sources and instituting new verification procedures, will be covered under this MOU and will not cause the need for a supplemental MOU that outlines these changes. DHS agrees to train employers on all changes made to E-Verify through the use of mandatory refresher tutorials and updates to the E-Verify manual. Even

Company ID Number: 47130

**INFORMATION REQUIRED
FOR THE E-VERIFY PROGRAM**

Information relating to your Company:

Company Name: Thompson Tractor Co., Inc.

Company Facility Address: 2401 Pinson Highway
Birmingham, AL 35217

Company Alternate Address: P.O. Box 10367
Birmingham, AL 35202-0367

County or Parish: JEFFERSON

Employer Identification Number: 630377478

North American Industry
Classification Systems Code: 423

Parent Company: _____

Number of Employees: 1,000 to
2,499 Number of Sites Verified for: 5

Are you verifying for more than 1 site? If yes, please provide the number of sites verified for in each State.

- GEORGIA 5 site(s)

Information relating to the Program Administrator(s) for your Company on policy questions or operational problems:

Name: **Kimberly A Stark**
Telephone Number: **(205) 849 - 4279** Fax Number: **(205) 849 - 4565**
E-mail Address: **kimberlystark@thompsontractor.com**

Name: **Frank M Wright**
Telephone Number: **(205) 849 - 4267** Fax Number: **(205) 849 - 4854**
E-mail Address: **frankwright@thompsontractor.com**

Request for Taxpayer Identification Number and Certification

Give form to the requester. Do not send to the IRS.

Print or type
 See Specific Instructions on page 2.

Name (as shown on your income tax return) Thompson Tractor Co., Inc. DBA Thompson Power Systems, Thompson Lift Truck Co.	
Business name, if different from above and The Cat Rent Store	
Check appropriate box: <input type="checkbox"/> Individual/Sole proprietor <input checked="" type="checkbox"/> Corporation <input type="checkbox"/> Partnership <input type="checkbox"/> Limited liability company. Enter the tax classification (D=disregarded entity, C=corporation, P=partnership) ▶ <input checked="" type="checkbox"/> Exempt payee <input type="checkbox"/> Other (see instructions) ▶	
Address (number, street, and apt. or suite no.) P O Box 10367 2401 Pinson Hwy. Tarrant, AL 35217	Requester's name and address (optional)
City, state, and ZIP code Birmingham, AL 35202-0367	
List account number(s) here (optional) Lockbox Remit To: P O Box 934005, Atlanta, GA 31193-4005	

Part I Taxpayer Identification Number (TIN)

Enter your TIN in the appropriate box. The TIN provided must match the name given on Line 1 to avoid backup withholding. For individuals, this is your social security number (SSN). However, for a resident alien, sole proprietor, or disregarded entity, see the Part I instructions on page 3. For other entities, it is your employer identification number (EIN). If you do not have a number, see *How to get a TIN* on page 3.

Social security number : : :
or
Employer identification number 63 : 0377478

Note. If the account is in more than one name, see the chart on page 4 for guidelines on whose number to enter.

Part II Certification

Under penalties of perjury, I certify that:

1. The number shown on this form is my correct taxpayer identification number (or I am waiting for a number to be issued to me), and
2. I am not subject to backup withholding because: (a) I am exempt from backup withholding, or (b) I have not been notified by the Internal Revenue Service (IRS) that I am subject to backup withholding as a result of a failure to report all interest or dividends, or (c) the IRS has notified me that I am no longer subject to backup withholding, and
3. I am a U.S. citizen or other U.S. person (defined below).

Certification Instructions. You must cross out item 2 above if you have been notified by the IRS that you are currently subject to backup withholding because you have failed to report all interest and dividends on your tax return. For real estate transactions, item 2 does not apply. For mortgage interest paid, acquisition or abandonment of secured property, cancellation of debt, contributions to an individual retirement arrangement (IRA), and generally, payments other than interest and dividends, you are not required to sign the Certification, but you must provide your correct TIN. See the instructions on page 4.

Sign Here	Signature of U.S. person ▶ <i>Linda K. Dumaux, Controller</i>	Date ▶
------------------	---	--------

General Instructions

Section references are to the Internal Revenue Code unless otherwise noted.

Purpose of Form

A person who is required to file an information return with the IRS must obtain your correct taxpayer identification number (TIN) to report, for example, income paid to you, real estate transactions, mortgage interest you paid, acquisition or abandonment of secured property, cancellation of debt, or contributions you made to an IRA.

Use Form W-9 only if you are a U.S. person (including a resident alien), to provide your correct TIN to the person requesting it (the requester) and, when applicable, to:

1. Certify that the TIN you are giving is correct (or you are waiting for a number to be issued),
2. Certify that you are not subject to backup withholding, or
3. Claim exemption from backup withholding if you are a U.S. exempt payee. If applicable, you are also certifying that as a U.S. person, your allocable share of any partnership income from a U.S. trade or business is not subject to the withholding tax on foreign partners' share of effectively connected income.

Note. If a requester gives you a form other than Form W-9 to request your TIN, you must use the requester's form if it is substantially similar to this Form W-9.

Definition of a U.S. person. For federal tax purposes, you are considered a U.S. person if you are:

- An individual who is a U.S. citizen or U.S. resident alien,
- A partnership, corporation, company, or association created or organized in the United States or under the laws of the United States,
- An estate (other than a foreign estate), or
- A domestic trust (as defined in Regulations section 301.7701-7).

Special rules for partnerships. Partnerships that conduct a trade or business in the United States are generally required to pay a withholding tax on any foreign partners' share of income from such business. Further, in certain cases where a Form W-9 has not been received, a partnership is required to presume that a partner is a foreign person, and pay the withholding tax. Therefore, if you are a U.S. person that is a partner in a partnership conducting a trade or business in the United States, provide Form W-9 to the partnership to establish your U.S. status and avoid withholding on your share of partnership income.

The person who gives Form W-9 to the partnership for purposes of establishing its U.S. status and avoiding withholding on its allocable share of net income from the partnership conducting a trade or business in the United States is in the following cases:

- The U.S. owner of a disregarded entity and not the entity.