

BID SUBMITTAL FORM
Alabama County Joint Bid Program
Heavy Equipment – HEAVY DUTY BACKHOE-OPTION A

Company Name: THOMPSON TRACTOR COMPANY

Address: P.O. BOX 10367
BIRMINGHAM, AL 35202-0367

Bid Submitted by: JAY SMITH
(Name of company representative)

Title: SALES OPERATIONS MANAGER E-mail address: JAYSMITH@THOMPSONTRACTOR.COM

Phone: (205) 849-4242 Fax: _____

By submitting this bid, we agree:

Initials

The equipment model number identified below meets the bid specs for this bid item.

JAS

That the bid price will be honored for all counties for the period from January 1, 2023 to December 31, 2023.

JAS

The equipment will be delivered at the bid price to all counties participating in the joint bid program.

JAS

The company acknowledges the freight preparation and delivery price is to be included in the total bid price for the standard machine.

JAS

The company representative listed above will be the contact person for purchasing this bid item under the joint bid program.

JAS

The bid is accompanied by a current catalog or model specification document for the model number identified below.

JAS

The bid is accompanied by a copy of the manufacturer's standard warranty as required in the bid specifications.

JAS

The bid includes the e-verify documentation required by Alabama law.

JAS

If awarded the bid, a performance bond will be provided upon request.

JAS

The bid documents include the **Manufacturer's Suggested Retail Price Sheet (MSRP) for the Standard Machine.**

JAS

Total Bid Price for Standard Machine: \$ 134,820
(Total Bid Price for Standard Machine Includes Freight Preparation, Delivery and Standard Warranty Costs) *

Freight Preparation and Delivery: \$ 5,192
(Included in Standard Machine Bid Price)

Manufacturer's Suggested Retail Price for Standard Machine: \$ 179,789

Equipment Model #: CATERPILLAR 430

Description: BACKHOE LOADER

Signature of company representative submitting bid: 

Title: SALES OPERATIONS MANAGER

* **NOTE:** Award will be made based on the total cost of the **Standard Machine**. The total cost of the standard machine is to include the freight preparation, delivery and standard warranty cost. Freight preparation, delivery will be excluded from the total bid price of the standard machine in determining the percentage discount for any available options.

BID SUBMITTAL FORM: OPTION COST SHEET

By submitting this bid, we agree:

To offer any available options at the percent difference between the Manufacturer's Suggested Retail Price Sheet and the actual bid price on the Standard Machine*

0%

The bid documents include the **Manufacturer's Suggested Retail Price Sheet (MSRP)** for the Standard Machine

0%

Equipment Model #: CATERPILLAR 430

Description: BACKHOE LOADER

Signature of company representative submitting bid: _____



Title: SALES OPERATIONS MANAGER

***Note:** The percent difference between the **Manufacturer's Suggested Retail Price Sheet (MSRP)** for the standard machine as specified by these **Bid Specifications** and the actual price bid by the vendor will be calculated to determine the percentage discount to be applied to any available options. The bid price of the freight preparation, delivery cost shall be excluded in determining the percentage discount to be applied to available options. Any individual county may choose to add any available option to the standard machine at the percentage discount at the time of purchase.

**BID SPECIFICATIONS
FOR
HEAVY DUTY BACKHOE-OPTION A**

GENERAL

These specifications shall be construed as the minimum acceptable standards for a heavy-duty backhoe. Should the manufacturer's current published data or specifications exceed these standards, the manufacturer's standards shall be considered minimum and shall be furnished. All integral parts not specifically mentioned in the scope of these specifications that are necessary to provide a complete working unit shall be furnished. Additionally, the machine offered for bid shall include all standard manufacturer's equipment. The heavy duty loader/backhoes must be a new current production model and shall meet all EPA and other applicable standards at the time of manufacture.

The use of specific names or numbers in the specifications is not intended to restrict the bidder or any seller or manufacturer, but is intended solely for the purpose of indicating the type, size and quality of equipment considered best adapted to the uses of counties participating in this joint bid.

BID SUBMITTAL FORM

Each bidder must submit his or her bid on the Bid Submittal Form included in the invitation to bid package. All written warranties to be submitted shall be attached to the Bid Submittal Form.

BID PRICE

The price bid shall include all destination charges, delivery charges, title fees, rebates and all other applicable costs and refunds.

MANUALS

Each unit shall be provided with one (1) copy of the operator's manual and one (1) copy of the current parts manual. Units will not be accepted for delivery until manuals as outlined above are received by the purchaser.

REPLACEMENT PARTS AVAILABILITY

Parts must be available for 5 years or 7,500 hours of use for the piece of equipment bid. If replacement parts are not delivered within three (3) working days of an order being placed, the bidder will deliver an equivalent machine for the County to use at no cost to the county until such time as the parts are delivered to the County so it can affect repairs to its machine.

WARRANTY

Bidders shall submit a copy of the manufacturer's standard warranty. Warranty shall include service response time of maximum of 36 hours within notification by county.

Yes No
Page#
or
Attachment

ENGINE

Four-cylinder, four stroke cycle, minimum 220 cubic inch diesel engine, capable of developing a minimum of 107 NET flywheel horsepower with turbo charger.

Yes No
Page # 1, 11

Must have an alternator with a minimum charging capacity of 120 amps.

Yes No
Page # 23

Engine must be designed and built by the machine manufacturer.

Yes No
Page # 1, 16, 23

STARTING SYSTEM

Shall be equipped with a 12-volt electrical system, heavy duty starting motor.

Yes No
Page # 13

Battery shall be a minimum of 880 CCA maintenance free.

Yes No
Page # 13

TRANSMISSION

Power shuttle transmission.

Yes No
Page # 6, 11, 12

Minimum of four (4) speeds forward and three (3) reverse speeds.

Yes No
Page # 11

Minimum travel speed: 24 mph.

Yes No
Page # 11

Transmission to have an electrical neutral lock switch.

Yes No
Page # 23

CONTROLS AND HYDRAULICS

Excavator style pilot-operated joystick controls with closed center, variable displacement load sensing hydraulic system.

Yes No
Page # 12, 23

Separate oil system for engine, transmission, rear axle and hydraulics.

Yes No
Page # 6, 10, 12

Must have pattern changer valve.

Yes No
Page # 23

Adjustable steering column.

Yes No
Page # 23

Air suspension seat.

Yes No
Page # 5, 23

FRONTEND LOADER

Loader Bucket -- 1.25 min. cu yd. heavy-duty

Yes No
Page # 16

Loader breakout force (lbs.) -- 11,020 lbs.

Yes No
Page # 16

Loader lift capacity max. Height (lbs.) -- 7,200 lbs.

Yes No
Page # 16

Loader pin height -- 11 ft. 5 in.

Yes No
Page # 16

Loader dump height -- 9 ft. 0 in.

Yes No
Page # 16

BACKHOE -- TWO LEVEL CONTROL SYSTEM (FIXED LENGTH DIPPER STICK)

Backhoe Bucket -- 24 in. heavy duty bucket (5 teeth)

Yes No
Page # 22

Bucket breakout force (lbs.) -- 16,150 lbs.

Yes No
Page # 17

Backhoe stick digging force (lbs.) -- 10,050 lbs.

Yes No
Page # 17

Boom Lift @ 12 ft. (lbs.) -- 3,200 lbs.

Yes No
Page # 20

Backhoe maximum digging depth -- 15 ft. 2 in.

Yes No
Page # 17

Backhoe maximum dumping height 13 ft. 0 in.

Yes No
Page # 17

BRAKES

Service brakes – hydraulic wet disk.

Yes No
Page # 23

Parking brake.

Yes No
Page # 15, 23

All wheel braking shall be available.

Yes No
Page # 6

FRONT AXLE

4-wheel drive

Yes No
Page # 12, 14

TIRES AND OUTRIGGERS

Reversible type for use on both paved and non-paved surfaces.

Yes No
Page # 24

Minimum 19.5L – 24/10 PR rear tires and wheels.

Yes No
Page # 12

Minimum 12.5/80 – 18/10 PR front tires and wheels.

Yes No
Page # 12

FUEL TANK

Minimum Capacity -- 42 Gallons

Yes No
Page # 12

OPEN ROPS CANOPY

Yes No
Page # 5, 23

OIL ANALYSIS

To be included at no cost of the duration of the warranty period selected at intervals recommended by the manufacturer's warranty and maintenance schedule.

Yes No
Page # —

WEIGHT (STANDARD OPERATING)

The factory specified operating weight only without options. No additional weights may be added for the purpose of meeting these specifications. Minimum 17,500 lbs. SAE standard.

Yes No
Page # 12

SAFETY DEVICES

Include a fire extinguisher that meets current minimum OSHA requirements complete with Mounting hardware installed on the machine.

Yes No
Page # VENDOR

Include a rotating or flashing safety beacon installed on top of the cab.

Yes No
Page # 24

430	HEAVY DUTY BACKHOE OPTION A	2023 Pricing
543-3343	430 BHL STANDARD	\$138,708
543-4285	STANDARD STICK 16 FT	\$0
544-1066	POWERTRAIN, 4WD, STANDARD SHIFT	\$13,119
543-5181	CAT C3.6 DITA ENGINE T4F	\$13,040
542-7771	GP HYDRAULICS, 5 FUNCTION / 7 BANK	\$983
544-0877	BASE CANOPY	\$0
545-5047	STANDARD DISPLAY	\$0
491-6734	8 HALOGEN WORKLIGHTS	\$0
573-4522	VINYL SEAT	\$0
206-1747	2" SUSPENSION SEAT BELT	\$0
560-6797	CELLULAR PRODUCT LINK PLE643	\$0
379-2161	12.5 80 / 19.5L-24 GOODYEAR TIRES	\$3,316
337-9696	COUNTERWEIGHT, 1,015 LBS	\$2,407
9R-6007	STABILIZER PADS, FLIP-OVER	\$459
545-8548	LOADER BUCKET PINS	\$0
337-7385	1.30 YD3 GENERAL PURPOSE BUCKET	\$4,190
9R-5320	TWO PIECE CUTTING EDGE	\$374
219-3396	24" HEAVY DUTY BUCKET	\$2,441
559-0872	ANSI INSTRUCTIONS	\$0
421-8926	SERIALIZED TECHNICAL MEDIA KIT	\$0
433-0154	STROBE BEACON MAGNETIC MOUNT	\$468
270-3204	BOOM WEAR PLATE GROUP	\$284
	TOTAL BID PRICE FOR STANDARD MACHINE	\$134,280
	FREIGHT PREPARATION AND DELIVERY	\$5,192
	TOTAL MANUFACTURER'S SUGGESTED RETAIL PRICE FOR STANDARD MACHINE	\$179,789

430F2/430F2 IT

Backhoe Loaders



Engine

Engine Model	Cat® C4.4 ACERT™	
Rated Net Power – SAE J1349	80 kW	108 hp
Rated Net Power – ISO 9249	81 kW	109 hp

Weights

Operating Weight – Minimum	7775 kg	17,141 lb
Operating Weight – Maximum (ROPS Capacity)	11 000 kg	24,251 lb

Backhoe

Dig Depth – Standard	4686 mm	15'4"
Dig Depth – E-Stick Extended	5935 mm	19'6"

Features

All New Operator Station

Built with the operator in mind, the new F2 Backhoe Loader cab provides additional machine control at the operator's fingertips, with differential lock and auxiliary functions on the loader joystick. Adjustable steering column as well as adjustable seat and hoe pod controls provide additional operator comfort.

Industry Leading Hydraulic Technology

Electronically controlled load sensing piston pump provides optimum response for loader and hoe productivity. New programmable auxiliary flow allows the machine to work more efficiently with work tool attachments.

Economy Mode

New technology allows the F2 Backhoe Loader to save fuel while maintaining performance in applications such as trenching, lifting and truck loading. Zero reduction in performance means increased efficiency on the job site.

Greater Versatility

Quick and easy attachment changing provides increased versatility and the ability to match the correct tool to the job application. The hydraulic backhoe coupler allows for a tool change without exiting the operation station. The loader hydraulic coupler, standard on the Integrated Toolcarrier (IT) Backhoe Loader, provides additional options for loader applications.

Superior Power and Performance

Industry leading structural design and hydraulics mean greater lifting power and breakout forces. Machine aggressiveness delivers outstanding productivity in the toughest applications.

Contents

Operator Station.....	4
Power Train.....	6
Advanced Hydraulics.....	7
Backhoe Performance.....	8
Loader Performance.....	8
Work Tools.....	9
Serviceability.....	10
Customer Support.....	10
Specifications.....	11
Standard Equipment.....	23
Optional Equipment.....	24
Notes.....	25





Experience the Backhoe Loader designed around customer feedback. The Cat 430F2 Backhoe Loader puts all the machine controls at the operator's fingertips. Operate all auxiliary controls with thumb rollers. Move from job site to job site quickly and smoothly with the additional 6th gear on the autoshift transmission and optional lock-up torque converter.

Operator Station

A cab designed for maximum comfort and productivity.

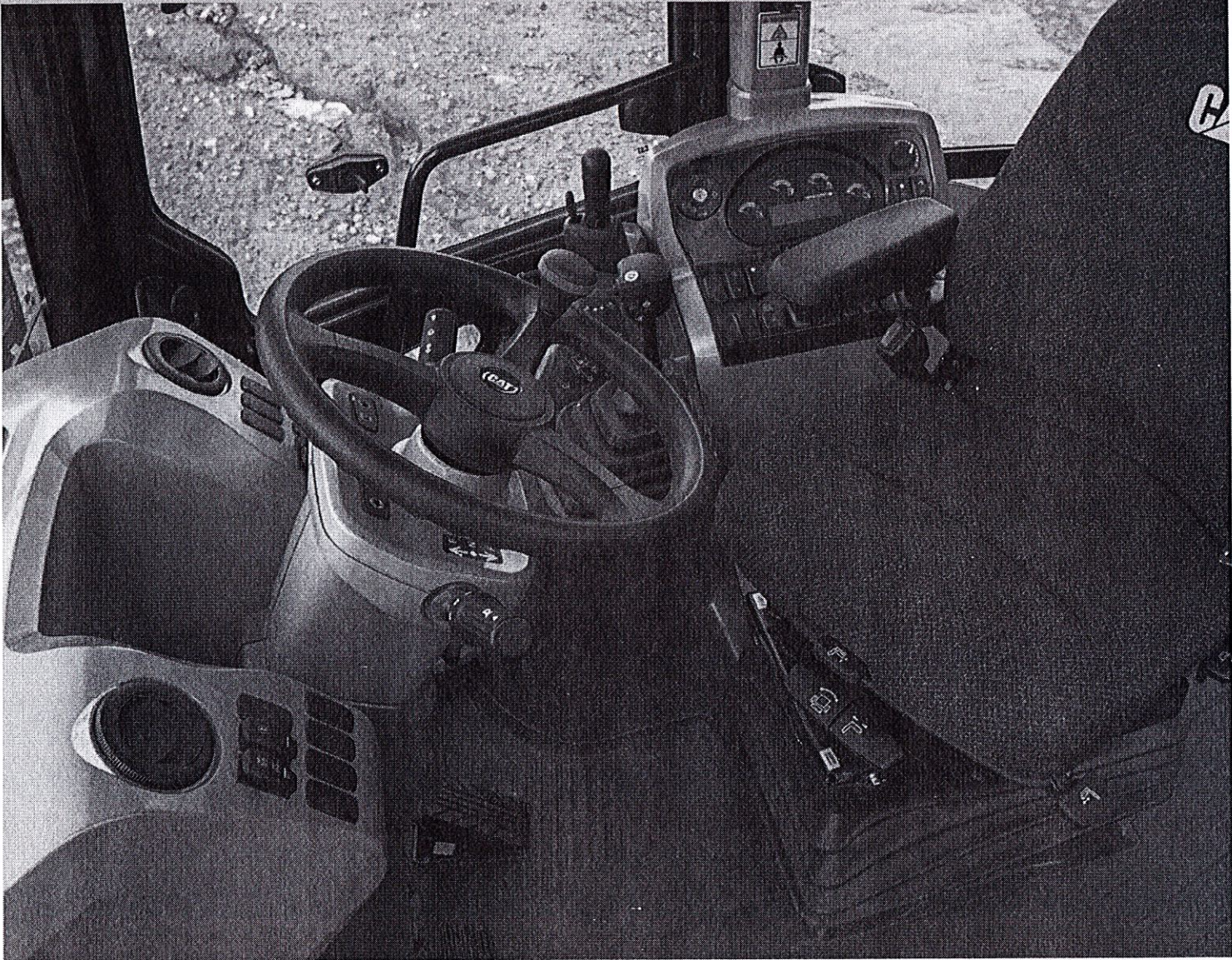

Joystick Controls

Cat Backhoe Loader joysticks are economically designed to provide precise control with low effort. Loader control levers on both the Single Tilt and Integrated Toolcarrier models offer a thumb roller for any 3rd function auxiliary. The differential lock control is newly located on the loader control to bring controllability to the operator's fingertips. New on the IT model is the forward, neutral, reverse control switch.



Unmatched Comfort

The ergonomic, automotive style operator station helps you work comfortably and productively all day long. Choose the configuration that meets your needs – Canopy, Cab Deluxe or Cab Deluxe with Air Conditioning. Other features include:

- Adjustable air suspension seat
- Tilt and telescoping steering column
- Excellent visibility over hood and up to bucket dump
- Pantograph windshield wiper
- Large front windshield screen
- Large LCD gauge cluster screen
- Ample legroom
- Optional heated seat
- Differential lock button on loader lever
- Large opening windows
- Solid roof cab
- LED brake lights

Ride Control

The optional Ride Control System smoothes the ride in all conditions, including load and carry, highway roading or simply moving around the job site. This results in increased operator comfort and improved material retention and facilitates a reduction in operator fatigue.

Pattern Selector

The pattern selector switch, located in the cab, lets you change from an excavator to a backhoe control pattern simply by pressing a button. This lets you use the pattern you are most comfortable with so you can be more productive.

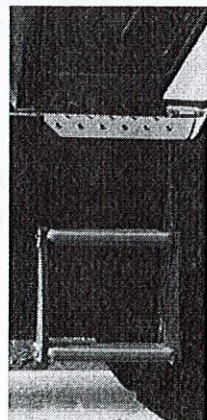

Premium Gauge Cluster

Bright and large LCD screen makes it easy to monitor machine operation and settings. LED indicator lights and audible alarms allow the machine to clearly communicate with the operator.

Safety Getting in and out of the Cab

New longer grab handles and ergonomic step placement makes it easy to maintain three points of contact when getting in and out of the cab.



Power Train

Always built for performance, power and efficiency.

Cat Engine

The Cat C4.4 ACERT engine operates quietly while delivering performance and durability. The engine meets U.S. EPA Tier 4 Final emission standards. Engine features include:

- Selective catalytic reduction
- Diesel oxidation catalyst
- Diesel exhaust fluid with system purge
- Limited operator interaction

Transmission

The standard power shuttle transmission provides four speeds forward and reverse. Hydraulically shifted clutches allow on-the-go direction and travel speed shifts. The optional auto-shift transmission matches gear with grade and load conditions. Now with six forward and reverse speeds, the machine can reach top speeds smoothly and quickly.

- The new optional lock-up torque converter, offered on the autoshift transmission, improves fuel efficiency up to 20% over the standard six gear autoshift. The lock-up torque converter also improves roading for long distances and with uphill climbs.
- Hydraulic proportional control valves deliver smooth speed and directional shifts.
- Standard Four Wheel Drive improves mobility and loader performance in poor underfoot conditions and can be activated on-the-go.
- Maximum roading speed of 40 km/h (25 mph) improves travel time between job sites.

Brake Mode Selector

Brake mode selector switch is standard on the 430F2 and has three positions: two wheel drive, two wheel drive with all wheel braking and four wheel drive. Two wheel drive with all wheel braking provides better tire life while roading and engages the front axle when brakes are applied for improved braking performance.

Advanced Hydraulics

Matching system power to job site demands.



Load Sensing Hydraulics

Closed center hydraulic system matches pressure and flow to application demand. Whether you're in full trenching mode or digging around delicate services, you remain in control. In applications such as production trenching where speed is important, the system will provide the flow needed to get the job done quickly and efficiently. The load sensing hydraulic system provides:

- Better fuel efficiency
- Electronically controlled
- Quieter operation
- Reduced component wear
- Cooler hydraulic temperatures
- Full forces at any engine speed

Flow Sharing Valves

Specifically tuned hydraulic valves allow for the multifunction of hydraulic components, without machine manipulation. Hydraulic fluid is shared between implements so that operation isn't interrupted.

Hydraulic Lines

Combination two way and one way flow hydraulic lines add versatility to the machine. By simply changing the lever position, the machine can efficiently run either style hydro mechanical tool.

Economy Mode

Cat Backhoe Loaders are able to reduce engine speed to 1,900 rpm while maintaining superior hydraulic power and performance.



Loader Performance

Powerful front loader.

Front loader arms deliver more reach, dump height and breakout. Choose the loader linkage that suits your application:

Powerful Single Tilt Loader Linkage

- Delivers strong lift and breakout forces for a solid performance in backfilling and truck loading applications with pin-on buckets.
- Optional third function hydraulics are now operated by an ergonomically designed thumb roller.
- The operator can now engage the differential lock with a press of a button on the loader lever for added machine control.

Integrated Toolcarrier (IT) loader linkage (optional) provides high breakout forces with parallel lift for efficient loading and material handling:

- The versatile integrated toolcarrier comes with a standard hydraulic quick coupler and can use a wide range of Cat Work Tools for a variety of applications.
- The single lever IT loader control provides fine modulation of hydraulic work tools. A thumb roller operates auxiliary hydraulic functions on work tools such as multi purpose buckets, brooms and other attachments.
- The IT loader lever provides additional machine control by offering the Forward, Neutral and Reverse control switch at the operator's fingertips.

Backhoe Performance

Superior digging forces.

Boom

The excavator-style boom is built for optimum performance and durability. The curved design provides added clearance when digging over obstacles or loading trucks. The narrow boom enhances the viewing area to the bucket and the trench throughout the operating range. More robust swing casting and double clevis design improves durability and reliability.

Stick

Serrated edges on the stick provide improved material clamping for clearing and demolition applications. The optional extendible stick (E-stick) increases reach and dig depth by approximately 1.2 m (4 ft).

Programmable Auxiliary Flow Control

- Three auxiliary settings for two auxiliary functions
- Accessed through the gauge cluster, operators can match the hydraulic flow of the machine to a work tool attachment

Thumbs

Thumb mounting provisions are standard on every Cat Backhoe Loader for added machine versatility. Cat hydraulic thumbs are available for even greater versatility. Mechanical thumbs are also available through your Cat dealer.



Work Tools

Do more jobs with one machine.

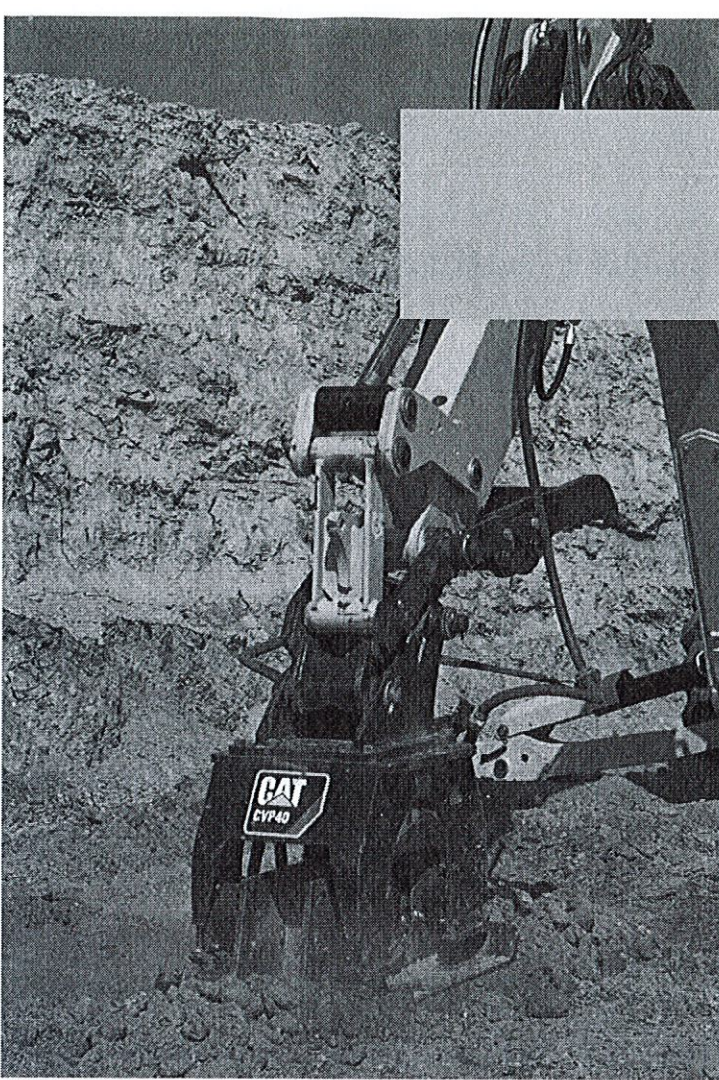

Backhoe Work Tools

Increase the versatility of your machine with the large selection of backhoe attachments:

- Buckets – Standard Duty, Heavy Duty, Heavy Duty Rock, Soil Excavation, Coral and Ditch Cleaning
- Cold Planers
- Hammers
- Augers
- Rippers
- Thumbs (mechanical and hydraulic)
- Vibratory Plate Compactors
- Quick Couplers

Loader Work Tools

A wide range of loader attachments is available including:

- Buckets – General Purpose, Multi Purpose, Side Dump and Light Material
- Angle Blades
- Brooms
- Rakes
- Forks
- Material Handling Arms
- Snow Plows

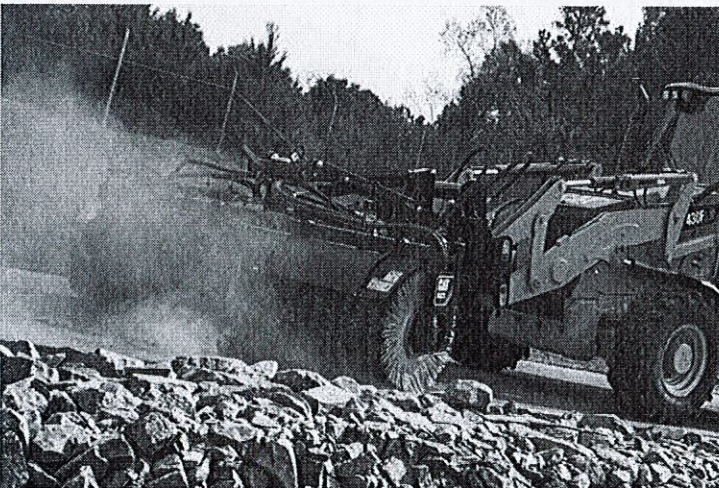

IT Loader Quick Coupler

The quick coupler allows fast and easy connection to work tools. Mechanical work tools can be changed in less than 30 seconds from the comfort of the operator station.



Backhoe Quick Coupler

Manual or hydraulic backhoe couplers make rear tool exchange quick and easy. New Cat dual lock coupler has a self-adjusting wedge design to ensure a tight fit. It also features a safety lock that automatically engages.

Serviceability

Easy maintenance helps keep your machine working.

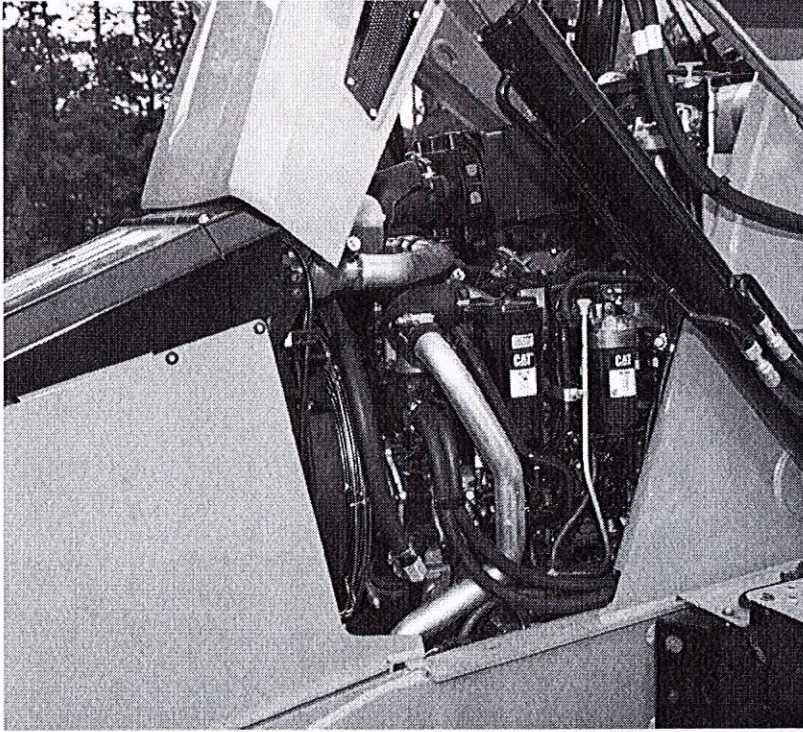

Minimize Your Downtime

Convenient service features make maintenance easy, reducing your downtime:

- Hinged cooling pack provides easy access
- Tilt up hood provides easy, convenient access to all engine check points
- Engine side panels remove easily without the use of tools
- Cat Product Link™ system (optional) provides remote reporting of machine location and operating system parameters

Customer Support

Unmatched support makes the difference.

Renowned Dealer Support

From helping you choose the right machine to knowledgeable ongoing support, Cat dealers provide the best in sales and service.

- Preventive maintenance programs and guaranteed maintenance contracts
- Best-in-class parts availability
- Operator training to help boost your profits
- Genuine Cat Remanufactured parts



430F2/430F2 IT Specifications

Engine

Engine Model	Cat C4.4 ACERT	
Gross Power		
SAE J1995	87 kW	117 hp
ISO 14396	86 kW	115 hp
Rated Net Power @ 2,200 rpm		
SAE J1349	80 kW	108 hp
ISO 9249	81 kW	109 hp
EEC 80/1269	81 kW	109 hp
Net Peak Power @ 1,800 rpm		
SAE J1349	82 kW	110 hp
ISO 9249	83 kW	111 hp
EEC 80/1269	83 kW	111 hp
Bore	105 mm	4.13 in
Stroke	127 mm	5 in
Displacement	4.4 L	268 in ³
Net Torque Rise @ 1,400 rpm – SAE J1349	39%	
Net Peak Torque @ 1,400 rpm	488 N·m	360 lbf-ft

- Engine meets Tier 4 Final emission standards.
- Net power ratings apply at 2,200 rpm when tested under the specified conditions for the specified standard.
- Net power advertised is the power available at the flywheel when the engine is equipped with fan, air cleaner, muffler and alternator.
- Based on standard air conditions of 25° C (77° F) and 99 kPa (29.32 in) in dry barometer.
- Used 35° API gravity fuel having an LHV of 42 780 kJ/kg (18,390 BTU/lb) when used at 30° C (89° F) (reference a fuel density of 838.9 g/L [7.001 lb/gal]).
- No derating required up to 3000 m (9,843 ft).
- Net torque rise meets SAE J1349.
- Net peak power ratings apply at conditions specified above.

Transmission

Power Shuttle Transmission – Standard

Forward – 1st	5.4 km/h	3.4 mph
Forward – 2nd	9 km/h	5.6 mph
Forward – 3rd	21 km/h	13 mph
Forward – 4th	40 km/h	25 mph
Reverse – 1st	5.4 km/h	3.4 mph
Reverse – 2nd	9 km/h	5.6 mph
Reverse – 3rd	21 km/h	13 mph
Reverse – 4th	40 km/h	25 mph

AutoShift Transmission – Optional

Forward – 1st	5.8 km/h	3.6 mph
Forward – 2nd	9.3 km/h	5.7 mph
Forward – 3rd	12 km/h	7 mph
Forward – 4th	19 km/h	12 mph
Forward – 5th	26 km/h	16 mph
Forward – 6th	40 km/h	25 mph
Reverse – 1st	5.8 km/h	3.6 mph
Reverse – 2nd	12 km/h	7.6 mph
Reverse – 3rd	28 km/h	17 mph

AutoShift Transmission with Lock-Up Torque Converter – Optional

Forward – 1st	5.8 km/h	3.6 mph
Forward – 2nd	9.3 km/h	5.7 mph
Forward – 3rd	12 km/h	7 mph
Forward – 4th	19 km/h	12 mph
Forward – 5th	23 km/h	14 mph
Forward – 5th LUC	25 km/h	15 mph
Forward – 6th	40 km/h	25 mph
Forward – 6th LUC	40 km/h	25 mph
Reverse – 1st	5.8 km/h	3.6 mph
Reverse – 2nd	12 km/h	7.6 mph
Reverse – 3rd	28 km/h	17 mph

- AutoShift automatically shifts between second gear and highest selected gear.
- Forward/reverse electric power shuttle is controlled by a conveniently placed, hand operated lever that provides instant direction changes between forward and reverse through power hydraulic clutches.
- Torque converter free-wheel clutch allows the converter stator to free-wheel during high speed, low torque conditions such as roading.
- Single-stage, 2.63:1 stall ratio.
- Travel speeds of two wheel drive backhoe loader at full throttle when equipped with 19.5 × 24 rear tires.

430F2/430F2 IT Specifications

Weights*

Operating Weight – Minimum	8330 kg	18,364 lb
Operating Weight – Maximum (ROPS Capacity)	11 000 kg	24,251 lb
Cab, ROPS/FOPS	163 kg	359 lb
AutoShift Transmission	238 kg	525 lb
Ride Control	14 kg	31 lb
Air Conditioning	42 kg	93 lb
MP Bucket (0.96 m ³ /1.25 yd ³) (no forks or teeth)	745 kg	1,642 lb
Loader, IT with Quick Coupler	317 kg	699 lb
Extendible Stick	305 kg	673 lb
Counterweights (Option 1)	115 kg	255 lb
Counterweights (Option 2)	240 kg	530 lb
Counterweights (Option 3)	460 kg	1,015 lb

* Specifications shown are for machine equipped with 1.0 m³ (1.31 yd³) general purpose loader bucket, 610 mm (24 in) heavy duty backhoe bucket, 80 kg (176 lb) operator and full fuel tank.

Steering

Type	Front Wheel	
Power Steering	Hydrostatic	
Bore	65 mm	2.6 in
Stroke	120 mm	4.7 in
Rod Diameter	36 mm	1.4 in
Axle Oscillation	11°	
Turning Circle – 4WD (inner wheel not braked)		
Outside, Front Wheels	8.18 m	26'10"
Outside, Widest Loading Bucket	10.97 m	36'0"

Axle Ratings

Front Axle, 2WD		
Static	22 964 kg	50,582 lb
Dynamic	9186 kg	20,233 lb
Front Axle, 4WD		
Static	22 964 kg	50,582 lb
Dynamic	9186 kg	20,233 lb
Rear Axle		
Static	22 964 kg	50,582 lb
Dynamic	9186 kg	20,233 lb
Axle Oscillation	10 Degrees	

• 4WD axles are pendulum mounted and permanently sealed and lubricated, requiring no daily maintenance. Also features double-acting steering cylinder with 52° steering angle for increased maneuverability.

Hydraulic System

Type	Closed Center	
Pump Type	Variable Flow, Axial Piston	
Pump Capacity @ 2,200 rpm	163 L/min	43 gal/min
System Pressure – Backhoe	25 000 kPa	3,600 psi
System Pressure – Loader	25 000 kPa	3,600 psi

Service Refill Capacities

Cooling System with Air Conditioning	22.5 L	5.9 gal
Fuel Tank	160 L	42 gal
Diesel Exhaust Fluid*	19 L	5 gal
Engine Oil with Filter	8.8 L	2.3 gal
Transmission – Power Shuttle		
4WD	15 L	4 gal
Transmission – AutoShift		
4WD	18 L	4.8 gal
Rear Axle	16.5 L	4.4 gal
Planetaries	1.7 L	0.4 gal
Front Axle (4WD)	11 L	2.9 gal
Planetaries	0.7 L	0.2 gal
Hydraulic System	95 L	25.1 gal
Hydraulic Tank	40 L	10.6 gal

* Must meet the requirements outlined in ISO 22241.
• Requires ultra-low sulfur fuel ≤ 15 ppm fuel sulfur.

Tires

Choices listed as combination of front/rear tires:

- Front: 12.5/80-18 (12 ply) 1-3; Rear: 19.5L-24 (12 ply) ATU
- Front: 12.5/80-18 NHS (12 ply) 1-3; Rear: 21L-24 (16 ply) R4 ATU
- Front: 340/80R18; Rear: 19.5L-24 (12 ply) R4 ATU
- Front: 340/80R18; Rear: 500/70R24 RT

Standards

Brakes	SAE J/ISO 3450; ISO 3450 1996
Cab – ROPS	SAE J1040 MAY94; ISO 3741 1994
Cab – FOPS	SAE J/ISO 3449 APR98 LEVEL II and ISO 3449: 1992 LEVEL II
Cab – Sound	ANSI/SAE J1166 OCT98 is 79 dB(A)
Exterior Sound	SAE J188 JUN86 is 76 dB(A)

Engine Features

- Regeneration is passive and does not require any input from the operator or disrupt work.
- Three-ring pistons made of lightweight, silicon/aluminum alloy for strength and maximum thermal conductivity.
- Forged chrome/molybdenum-steel crankshaft with crankshaft with either induction hardened or nitrocarburized journals.
- Front and rear crankshaft oil seals are “lip” type Viton and PTFE designs featuring an integral dust lip.
- Heat resistant, silicone-chrome steel intake and STELLITE-faced exhaust valves provide long life.
- Cylinder block is high strength, cast iron alloy of deep skirt, monobloc design for increased strength and long life.
- Cylinder head is high strength, cast iron alloy construction with extra duty wall and deck thickness. Intake and exhaust ports are precision cast to promote optimum gas flow.
- Direct injection fuel system provides accurate fuel delivery; remote mounted electric lift pump improves serviceability.
- Dry-type axial seal air cleaner with integral precleaner, automatic dust ejection system, and filter condition indicator.
- Direct electric, 12-volt starting and charging system with 880 CCA Group 31 maintenance free battery.
- Standard glow plug starting aid system for efficient cold weather starting.
- High contact ratio/gear train, peripheral fixed isolation top cover and open deck block design reduce bare engine noise.
- Higher low end torque for better engine/machine performance.
- Engine is equipped with electric fuel priming pump.

Brakes

Features:

- Brakes meet the following standards: SAE J1473 and ISO 3450 requirements.
- Self-adjusting, completely enclosed and sealed.
- Foot operated brake pedals can be interlocked for roading.
- Parking/secondary brakes are independent of the service brake system. Parking brake is mechanically applied through an adjustable hand lever located on the right console.

430F2/430F2 IT Specifications

Machine Dimensions

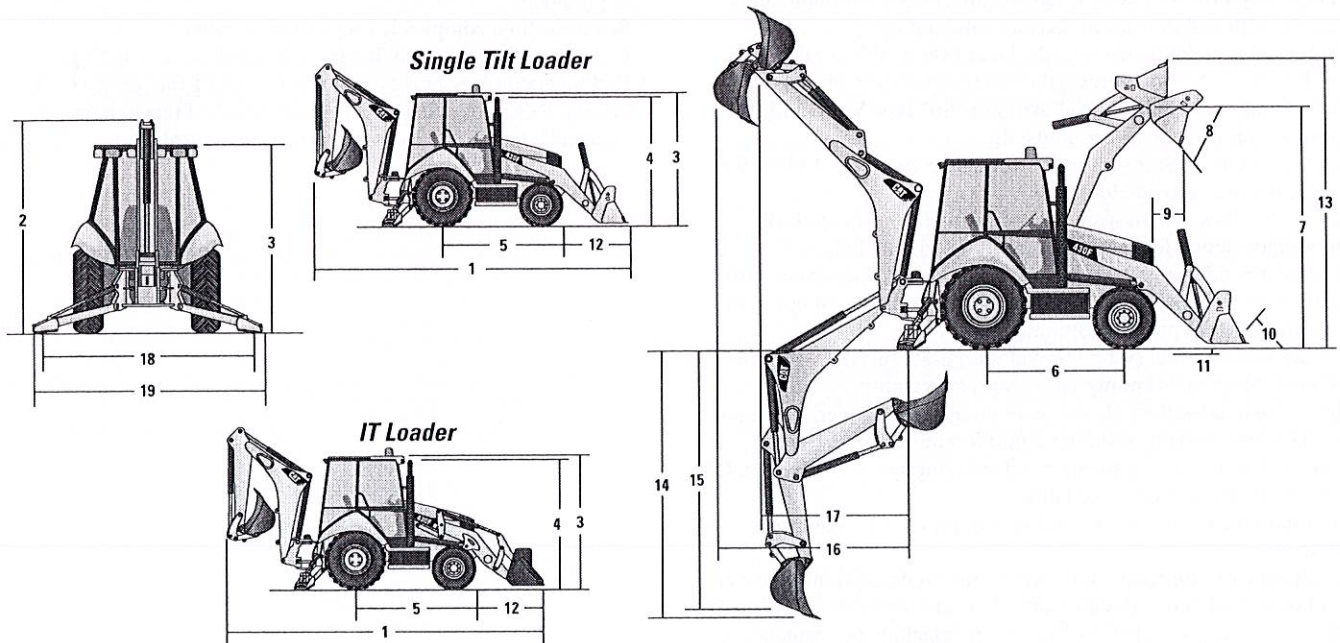

	Single Tilt Loader									
	General Purpose (0.96 m ³ /1.25 yd ³)		General Purpose (1.1 m ³ /1.4 yd ³)		General Purpose (1.15 m ³ /1.5 yd ³)		Multi Purpose (1.0 m ³ /1.31 yd ³)		Multi Purpose (1.1 m ³ /1.4 yd ³)	
1 Overall Transport Length	7310 mm	24'0"	7302 mm	23'11"	7302 mm	23'11"	7274 mm	23'10"	7200 mm	23'7"
Overall Length (loader on ground)	7282 mm	23'11"	7348 mm	24'1"	7348 mm	24'1"	7200 mm	23'7"	7274 mm	23'10"
2 Overall Transport Height – Standard Stick	3577 mm	11'9"	3577 mm	11'9"	3577 mm	11'9"	3577 mm	11'9"	3577 mm	11'9"
Overall Transport Height – Extendible Stick	3631 mm	11'11"	3631 mm	11'11"	3631 mm	11'11"	3631 mm	11'11"	3631 mm	11'11"
Overall Width	2322 mm	7'7"	2322 mm	7'7"	2322 mm	7'7"	2322 mm	7'7"	2322 mm	7'7"
3 Height to Top of Cab/Canopy	2819 mm	9'3"	2819 mm	9'3"	2819 mm	9'3"	2819 mm	9'3"	2819 mm	9'3"
4 Height to Top of Exhaust Stack	2744 mm	9'0"	2744 mm	9'0"	2744 mm	9'0"	2744 mm	9'0"	2744 mm	9'0"
Height to Loader Hinge Pin (transport)	381 mm	1'3"	428 mm	1'5"	428 mm	1'5"	432 mm	1'5"	432 mm	1'5"
Ground Clearance (minimum)	294 mm	1'0"	294 mm	1'0"	294 mm	1'0"	294 mm	1'0"	294 mm	1'0"
5 Rear Axle Centerline to Front Grill	2705 mm	8'10"	2705 mm	8'10"	2705 mm	8'10"	2705 mm	8'10"	2705 mm	8'10"
Front Wheel Tread Gauge	1895 mm	6'3"	1895 mm	6'3"	1895 mm	6'3"	1895 mm	6'3"	1895 mm	6'3"
Rear Wheel Tread Gauge	1714 mm	5'7"	1714 mm	5'7"	1714 mm	5'7"	1714 mm	5'7"	1714 mm	5'7"
6 Wheelbase 2WD/AWD	2200 mm	7'3"	2200 mm	7'3"	2200 mm	7'3"	2200 mm	7'3"	2200 mm	7'3"

Dimensions and performance specifications shown are for machines equipped with 12.5/80-18 SGL front tires, 19.5L-24 IT525 rear tires, ROPS canopy, standard stick with 610 mm (24 in) standard duty bucket, 1.0 m³ (1.31 yd³) loader bucket and standard equipment unless otherwise specified.

430F2/430F2 IT Specifications

Machine Dimensions

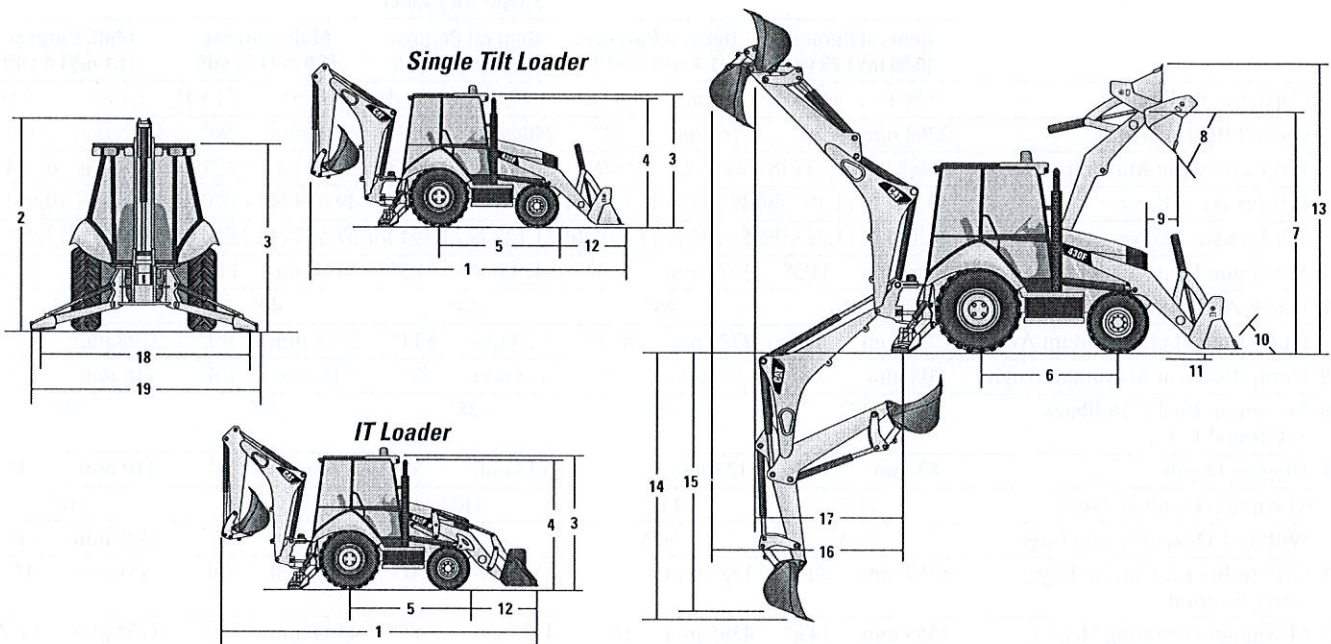

IT Loader with Quick Coupler

	General Purpose (0.96 m ³ /1.25 yd ³)		General Purpose (1.15 m ³ /1.5 yd ³)		Multi Purpose (1.0 m ³ /1.31 yd ³)	
	mm	ft/in	mm	ft/in	mm	ft/in
1 Overall Transport Length	7423	24'4"	7428	24'4"	7352	24'1"
Overall Length (loader on ground)	7430	24'5"	7420	24'4"	7338	24'1"
2 Overall Transport Height – Standard Stick	3577	11'9"	3577	11'9"	3577	11'9"
Overall Transport Height – Extendible Stick	3631	11'11"	3631	11'11"	3631	11'11"
Overall Width	2322	7'7"	2322	7'7"	2322	7'7"
3 Height to Top of Cab/Canopy	2819	9'3"	2819	9'3"	2819	9'3"
4 Height to Top of Exhaust Stack	2744	9'0"	2744	9'0"	2744	9'0"
Height to Loader Hinge Pin (transport)	396	1'4"	391	1'3"	386	1'3"
Ground Clearance (minimum)	294	1'0"	294	1'0"	294	1'0"
5 Rear Axle Centerline to Front Grill	2705	8'10"	2705	8'10"	2705	8'10"
Front Wheel Tread Gauge	1895	6'3"	1895	6'3"	1895	6'3"
Rear Wheel Tread Gauge	1714	5'7"	1714	5'7"	1714	5'7"
6 Wheelbase 2WD/4WD	2200	7'3"	2200	7'3"	2200	7'3"

Dimensions and performance specifications shown are for machines equipped with 12.5/80-18 SGL front tires, 19.5L-24 IT525 rear tires, ROPS canopy, standard stick with 610 mm (24 in) standard duty bucket, 1.0 m³ (1.31 yd³) loader bucket and standard equipment unless otherwise specified.

430F2/430F2 IT Specifications

Loader Bucket Dimensions and Performance

	Single Tilt Loader									
	General Purpose (0.96 m ³ /1.25 yd ³)		General Purpose (1.1 m ³ /1.4 yd ³)		General Purpose (1.15 m ³ /1.5 yd ³)		Multi Purpose (1.0 m ³ /1.31 yd ³)		Multi Purpose (1.1 m ³ /1.4 yd ³)	
Capacity (SAE rated)	0.96 m ³	1.25 yd ³	1.1 m ³	1.4 yd ³	1.15 m ³	1.5 yd ³	1.0 m ³	1.31 yd ³	1.1 m ³	1.4 yd ³
Overall Bucket Width	2262 mm	89"	2262 mm	89"	2406 mm	95"	2279 mm	90"	2425 mm	95"
Lift Capacity at Maximum Height	3282 kg	7,237 lb	3216 kg	7,090 lb	3196 kg	7,046 lb	3097 kg	6,828 lb	3068 kg	6,764 lb
Lift Breakout Force	49 809 N	11,197 lbf	49 275 N	11,077 lbf	49 099 N	11,037 lbf	49 019 N	11,020 lbf	48 771 N	10,964 lbf
Tilt Breakout Force	50 190 N	11,283 lbf	51 236 N	11,518 lbf	51 128 N	11,494 lbf	57 555 N	12,938 lbf	57 408 N	12,905 lbf
7 Maximum Hinge Pin Height	3474 mm	11'5"	3474 mm	11'5"	3474 mm	11'5"	3474 mm	11'5"	3474 mm	11'5"
8 Dump Angle at Full Height	44°		44°		44°		44°		44°	
Dump Height at Maximum Angle	2746 mm	9'0"	2723 mm	8'11"	2723 mm	8'11"	2798 mm	9'2"	2798 mm	9'2"
9 Dump Reach at Maximum Angle	808 mm	2'8"	773 mm	2'6"	773 mm	2'6"	716 mm	2'4"	716 mm	2'4"
10 Maximum Bucket Rollback at Ground Level	37°		38°		38°		38°		38°	
11 Digging Depth	83 mm	3"	123 mm	5"	123 mm	5"	110 mm	4"	110 mm	4"
Maximum Grading Angle	112°		113°		113°		116°		116°	
Width of Dozer Cutting Edge	N/A		N/A		N/A		2262 mm	7'5"	2406 mm	7'11"
12 Grill to Bucket Cutting Edge, Carry Position	1487 mm	4'11"	1525 mm	5'0"	1525 mm	5'0"	1451 mm	4'9"	1451 mm	4'9"
13 Maximum Operating Height	4355 mm	14'3"	4395 mm	14'5"	4395 mm	14'5"	4404 mm	14'5"	4404 mm	14'5"
Jaw Opening Maximum	N/A		N/A		N/A		790 mm	2'7"	790 mm	2'7"
Bucket Jaw Clamping Force	N/A		N/A		N/A		55 700 N	12,521 lbf	55 700 N	12,521 lbf
Weight (does not include teeth or forks)	451 kg	994 lb	473 kg	1,043 lb	493 kg	1,087 lb	745 kg	1,642 lb	774 kg	1,706 lb

	IT Loader with Quick Coupler					
	General Purpose (0.96 m ³ /1.25 yd ³)		General Purpose (1.15 m ³ /1.5 yd ³)		Multi Purpose (1.0 m ³ /1.31 yd ³)	
Capacity (SAE rated)	0.96 m ³	1.25 yd ³	1.15 m ³	1.5 yd ³	1.0 m ³	1.31 yd ³
Overall Bucket Width	2262 mm	89"	2406 mm	95"	2279 mm	90"
Lift Capacity at Maximum Height	3716 kg	8,193 lb	3655 kg	8,058 lb	3448 kg	7,601 lb
Lift Breakout Force	51 085 N	11,484 lbf	50 555 N	11,365 lbf	49 452 N	11,117 lbf
Tilt Breakout Force	46 286 N	10,405 lbf	46 106 N	10,365 lbf	50 349 N	11,318 lbf
7 Maximum Hinge Pin Height	3490 mm		3490 mm		3490 mm	
8 Dump Angle at Full Height	44°		44°		44°	
Dump Height at Maximum Angle	2679 mm	8'9"	2680 mm	8'10"	2745 mm	9'0"
9 Dump Reach at Maximum Angle	869 mm	2'10"	868 mm	2'10"	814 mm	2'8"
10 Maximum Bucket Rollback at Ground Level	40°		40°		39°	
11 Digging Depth	105 mm	4"	105 mm	4"	95 mm	4"
Maximum Grading Angle	110°		110°		112°	
Width of Dozer Cutting Edge	N/A		N/A		2262 mm	7'5"
12 Grill to Bucket Cutting Edge, Carry Position	1600 mm	5'3"	1597 mm	5'3"	1529 mm	5'0"
13 Maximum Operating Height	4407 mm	14'6"	4477 mm	14'8"	4480 mm	14'8"
Jaw Opening Maximum	N/A		N/A		790 mm	2'7"
Bucket Jaw Clamping Force	N/A		N/A		55 700 N	12,521 lbf
Weight (does not include teeth or forks)	447 kg	985 lb	481 kg	1,060 lb	724 kg	1,596 lb

Dimensions and performance specifications shown are for machines equipped with 12.5/80-18 SGL front tires, 19.5L-24 IT525 rear tires, ROPS canopy, standard stick with 610 mm (24 in) standard duty bucket, 1.0 m³ (1.31 yd³) loader bucket and standard equipment unless otherwise specified.

430F2/430F2 IT Specifications

Backhoe Dimensions and Performance

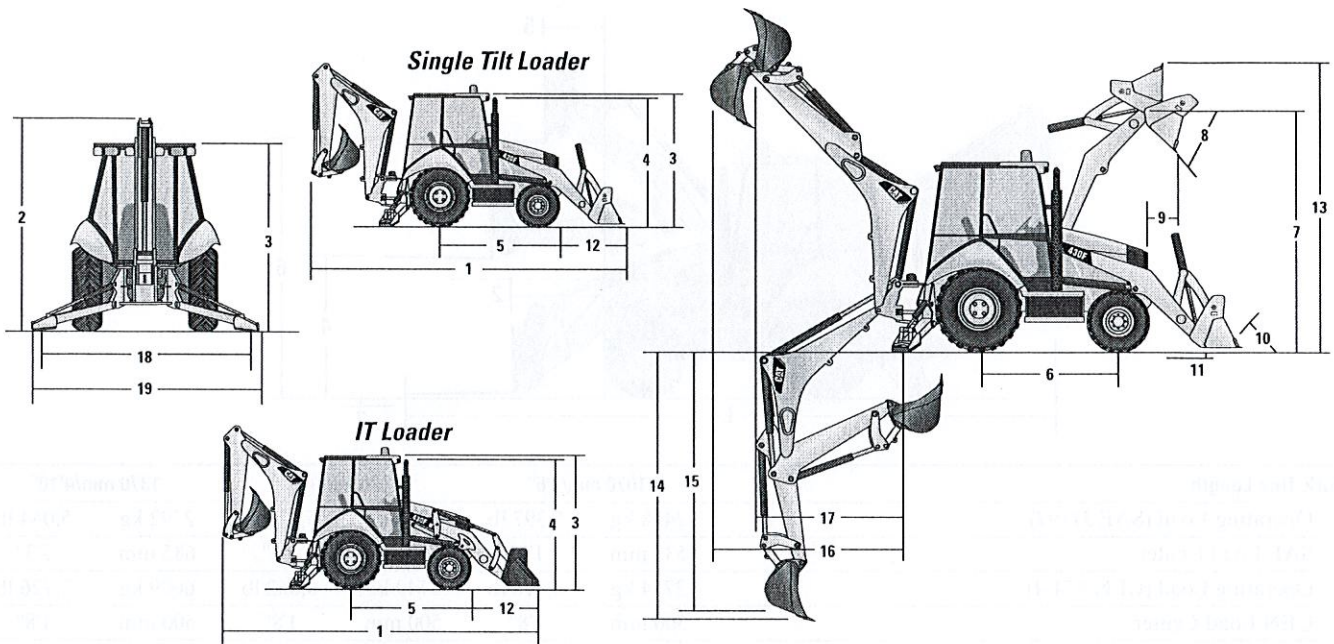

	Standard Stick		E-Stick Retracted		E-Stick Extended	
14 Digging Depth, SAE (maximum)	4686 mm	15'4"	4795 mm	15'9"	5935 mm	19'6"
15 Digging Depth, 610 mm (2 ft) Flat Bottom	4660 mm	15'3"	4766 mm	15'8"	5906 mm	19'5"
Reach from Rear Axle Centerline at Ground Line	7133 mm	23'6"	7227 mm	23'10"	8316 mm	27'5"
16 Reach from Swing Pivot at Ground Line	6043 mm	19'10"	6137 mm	20'2"	7226 mm	23'9"
Maximum Operating Height	6007 mm	19'9"	6075 mm	20'0"	6958 mm	22'11"
Loading Height	3961 mm	13'0"	3921 mm	12'10"	4533 mm	14'10"
17 Loading Reach	1855 mm	6'1"	2022 mm	6'8"	3003 mm	9'10"
Swing Arc	180°		180°		180°	
Bucket Rotation	205°		205°		205°	
18 Stabilizer Spread, Operating Position (center)	3310 mm	10'10"	3310 mm	10'10"	3310 mm	10'10"
Stabilizer Spread, Operating Position (outside)	3770 mm	12'4"	3770 mm	12'4"	3770 mm	12'4"
Stabilizer Spread, Transport Position	2322 mm	7'7"	2322 mm	7'7"	2322 mm	7'7"
Bucket Dig Force	71 864 N	16,156 lbf	70 870 N	15,932 lbf	70 870 N	15,932 lbf
Stick Dig Force	44 778 N	10,067 lbf	43 841 N	9,856 lbf	32 414 N	7,287 lbf

Dimensions and performance specifications shown are for machines equipped with 12.5/80-18 SGL front tires, 19.5L-24 IT525 rear tires, ROPS canopy, standard stick with 610 mm (24 in) standard duty bucket, 1.0 m³ (1.31 yd³) loader bucket and standard equipment unless otherwise specified.

430F2/430F2 IT Specifications

Dimensions with Forks

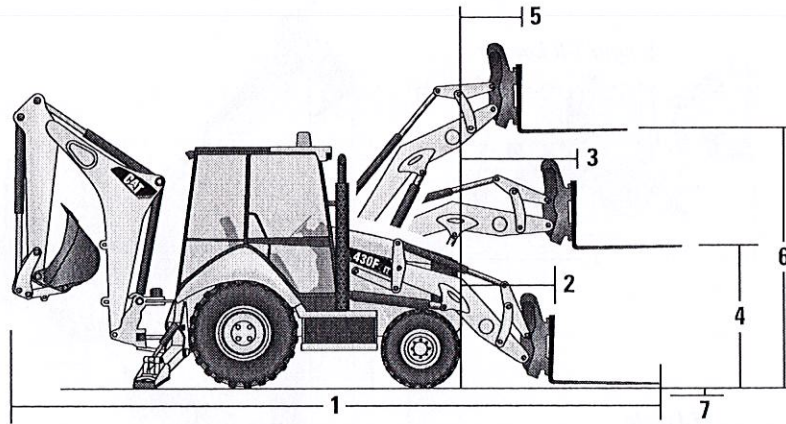

Fork Tine Length	1070 mm/3'6"		1220 mm/4'0"		1370 mm/4'10"	
Operating Load (SAE J1197)	2448 kg	5,397 lb	2368 kg	5,220 lb	2292 kg	5,054 lb
SAE Load Center	535 mm	1'9"	610 mm	2'0"	685 mm	2'3"
Operating Load (CEN 474-4)	2774 kg	6,116 lb	2749 kg	6,062 lb	6009 kg	2,726 lb
CEN Load Center	500 mm	1'8"	500 mm	1'8"	500 mm	1'8"
1 Overall Length (forks on ground)	7822 mm	25'8"	7973 mm	26'2"	8121 mm	26'8"
2 Reach at Ground (from grill to heel of fork)†	938 mm	3'1"	939 mm	3'1"	937 mm	3'1"
3 Maximum Reach (from grill to heel of fork)†	1475 mm	4'10"	1475 mm	4'10"	1475 mm	4'10"
4 Fork Height at Maximum Reach	1588 mm	5'3"	1588 mm	5'3"	1587 mm	5'2"
5 Reach at Maximum Height (from grill to heel of fork)†	696 mm	2'3"	696 mm	2'3"	696 mm	2'3"
6 Maximum Fork Height	3410 mm	11'2"	3410 mm	11'2"	3410 mm	11'2"
7 Maximum Fork Depth (below ground level)	-6 mm	0"	-5 mm	0"	-8 mm	0"

Dimensions and performance specifications shown are for machines equipped with 12.5/80-18 SGL front tires, 19.5L-24 IT525 rear tires, ROPS canopy, standard stick with 610 mm (24 inch) standard duty bucket, and 1.0 m³ (1.31 yd³) loader bucket and standard equipment unless otherwise specified.

430F2/430F2 IT Specifications

Dimensions with Material Handling Arm

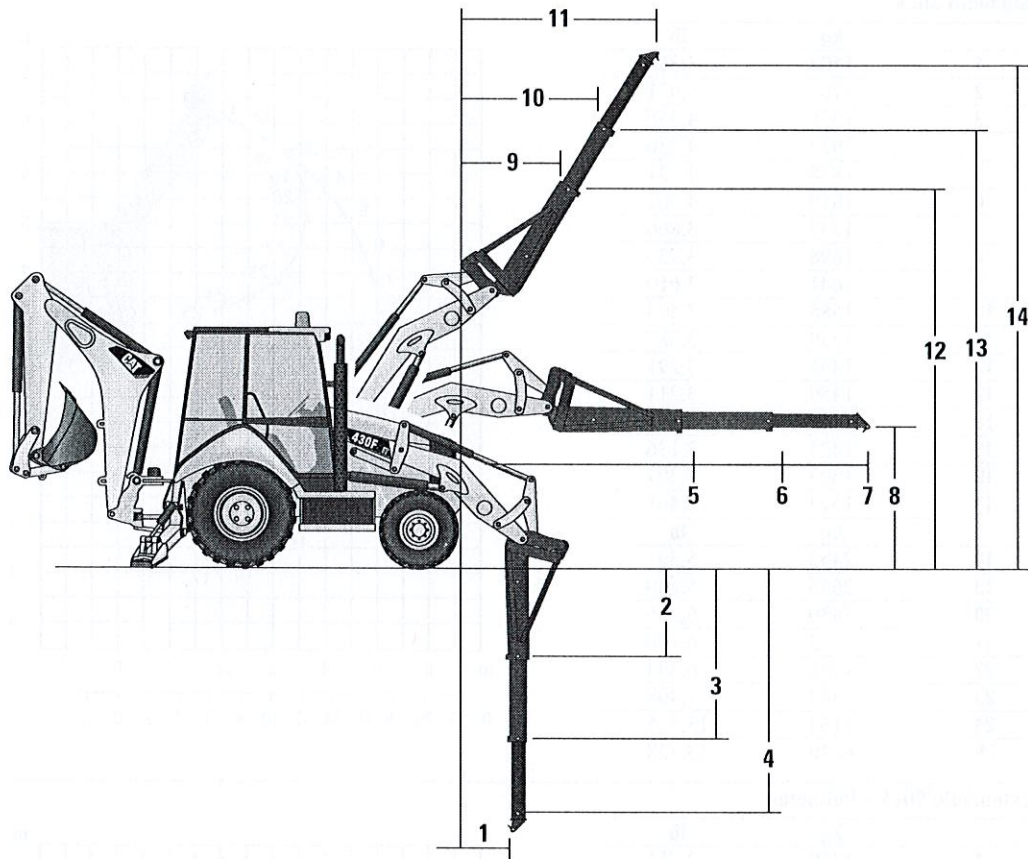

Material Handling Arm Position	Retracted		Mid-Position		Extended	
Operating Load (SAE J1197 and CEN 474-4)*	1056 kg	2,328 lb	674 kg	1,487 lb	494 kg	1,089 lb
Overall Length, Maximum	9008 mm	29'7"	10 005 kg	32'10"	11 005 kg	36'1"
1 Reach at Maximum Depth (from machine nose)	589 mm	1'11"	592 mm	1'11"	595 mm	1'11"
2, 3, 4 Maximum Depth	2532 mm	8'4"	3530 mm	11'7"	4530 mm	14'10"
5, 6, 7 Maximum Reach (from machine nose)	3184 mm	10'5"	4182 mm	13'9"	5182 mm	17'0"
8 Height at Maximum Reach	1101 mm	3'7"	1103 mm	3'7"	1106 mm	3'8"
9, 10, 11 Reach at Maximum Height (from machine nose)	1577 mm	5'2"	2164 mm	7'1"	2755 mm	9'0"
12, 13, 14 Maximum Height	4570 mm	15'0"	5377 mm	17'8"	6183 mm	20'3"

*Hydraulically limited.

Dimensions and performance specifications shown are for machines equipped with 12.5/80-18 SGL front tires, 19.5L-24 IT525 rear tires, ROPS canopy, standard stick with 610 mm (24 inch) standard duty bucket, and 1.0 m³ (1.31 yd³) loader bucket and standard equipment unless otherwise specified.

430F2/430F2 IT Specifications

Backhoe Lift Capacity

Cat 430F2/430F2 IT Standard Stick

Boom Lifting	kg	lb
1	1508	3,318
2	1782	3,921
3	1936	4,258
4	1925	4,236
5	1878	4,131
6	1819	4,001
7	1757	3,866
8	1698	3,735
9	1641	3,610
10	1588	3,493
11	1539	3,387
12	1496	3,291
13	1459	3,211
14	1432	3,151
15	1425	3,136
16	1503	3,307
17	1573	3,461
Stick Lifting	kg	lb
18	2453	5,397
19	2636	5,800
20	2830	6,226
21	2773	6,100
22	2906	6,394
23	3367	7,408
24	6152	13,535
25	6240	13,728

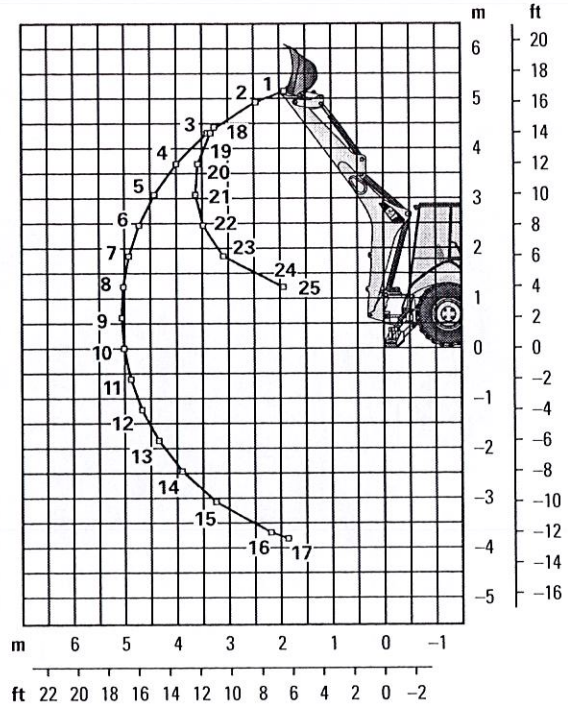

Cat 430F2/430F2 IT Extendible Stick – Retracted

Boom Lifting	kg	lb
1	1250	2,751
2	1541	3,391
3	1663	3,659
4	1654	3,639
5	1610	3,542
6	1555	3,421
7	1497	3,294
8	1441	3,169
9	1386	3,049
10	1335	2,936
11	1287	2,832
12	1244	2,738
13	1207	2,656
14	1178	2,593
15	1166	2,565
16	1211	2,665
17	1316	2,896
Stick Lifting	kg	lb
18	2158	4,747
19	2367	5,208
20	2538	5,583
21	2486	5,469
22	2599	5,719
23	2979	6,553
24	4516	9,934
25	6083	13,382

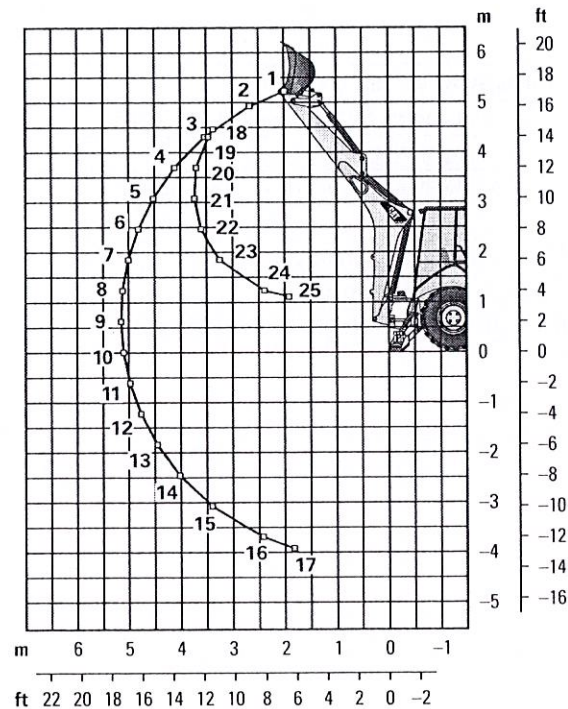

Lift Capacities are over-end values. Machine equipped with 4WD, OROPS, 0.96 m³ (1.25 yd³) general purpose bucket, and no counterweight. Extendible stick includes 460 kg (1,015 lb) counterweight.

430F2/430F2 IT Specifications

Backhoe Lift Capacity

Cat 430F2/430F2 IT Extendible Stick – Extended

Boom Lifting	kg	lb
1	679	1,493
2	1017	2,237
3	1124	2,474
4	1158	2,547
5	1167	2,553
6	1149	2,527
7	1129	2,484
8	1106	2,433
9	1081	2,378
10	1056	2,323
11	1032	2,270
12	1009	2,220
13	989	2,176
14	972	2,138
15	959	2,111
16	954	2,100
17	963	2,119
18	1005	2,210
19	1211	2,663
Stick Lifting	kg	lb
20	1197	2,633
21	1277	2,810
22	1565	3,444
23	1735	3,817
24	1715	3,774
25	1753	3,856
26	1860	4,092
27	2079	4,575
28	2563	5,638
29	4910	10,802
30	5883	12,943

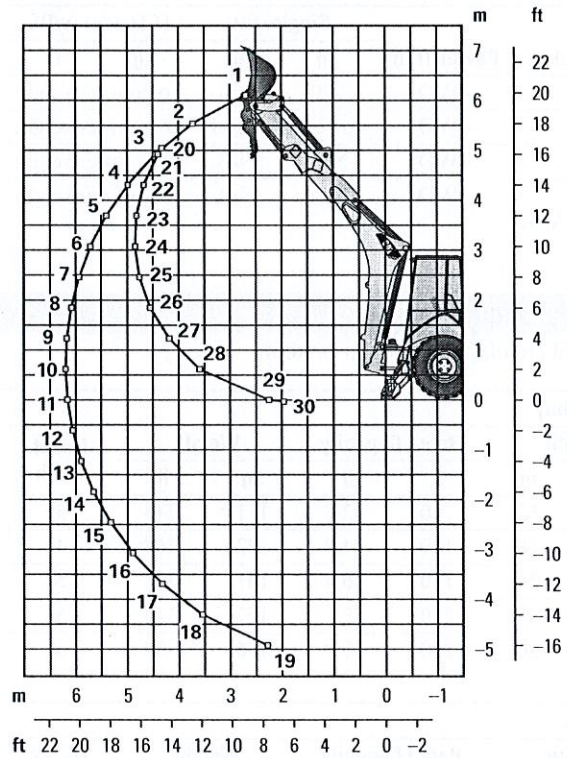

Lift Capacities are over-end values. Machine equipped with 4WD, OROPS, 0.96 m³ (1.25 yd³) general purpose bucket, and no counterweight. Extendible stick includes 460 kg (1,015 lb) counterweight.

430F2/430F2 IT Specifications

Counterweights

Minimum Counterweight Recommendations

Standard Stick

Loader Bucket	Power Train	Single-Tilt		IT Loader w/QC	
		kg	lb	kg	lb
GP	4WD	240	530	no counterweight	
MP	4WD	no counterweight		no counterweight	
Forks	4WD	N/A	N/A	no counterweight	
Material Handling Arm	4WD	N/A	N/A	no counterweight	

Extendible Stick

Loader Bucket	Power Train	Single-Tilt		IT Loader w/QC	
		kg	lb	kg	lb
GP	4WD	460	1,015	460	1,015
MP	4WD	240	530	no counterweight	
Forks	4WD	N/A	N/A	240	530
Material Handling Arm	4WD	N/A	N/A	240	530

Backhoe Buckets

With weld on adapters and pin-on teeth

Standard Duty

Width		Rated Capacity		Weight		No. of Teeth
mm	in	L	ft ³	kg	lb	
305	12	80	2.8	111	245	3
457	18	120	4.2	122	268	4
610	24	180	6.4	141	311	5
762	30	230	8.1	157	345	5
914	36	290	10.2	176	388	6

Coral

Width		Rated Capacity		Weight		No. of Teeth
mm	in	L	ft ³	kg	lb	
305	12	60	2.1	134	295	4
457	18	100	3.5	155	341	6
610	24	140	4.9	182	402	8
762	30	190	6.7	210	463	10

Heavy Duty

Width		Rated Capacity		Weight		No. of Teeth
mm	in	L	ft ³	kg	lb	
305	12	80	2.8	121	266	3
406	16	110	3.9	128	282	3
457	18	120	4.2	135	299	4
610	24	180	6.4	151	333	5
762	30	230	8.1	177	391	5
914	36	290	10.2	201	443	6

Heavy Duty – Pin Lock

Width		Rated Capacity		Weight		No. of Teeth
mm	in	L	ft ³	kg	lb	
305	12	96	3.4	113	249	3
406	16	123	4.3	131	288	3
457	18	139	4.9	139	307	4
610	24	207	7.3	168	370	5
762	30	275	9.7	194	428	5
914	36	345	12.2	224	494	6

Soil Excavation

Width		Rated Capacity		Weight		No. of Teeth
mm	in	L	ft ³	kg	lb	
457	18	180	6.4	155	341	4
610	24	240	8.5	182	402	5
762	30	320	11.3	206	454	5
914	36	380	13.4	233	513	6

High Capacity – Pin Lock

Width		Rated Capacity		Weight		No. of Teeth
mm	in	L	ft ³	kg	lb	
305	12	96	4.6	113	287	3
406	16	123	5.6	131	327	3
457	18	139	6.5	139	346	4
610	24	207	9.6	168	414	5
762	30	275	12.9	194	475	5
914	36	345	16.2	224	543	6

Heavy Duty Rock

Width		Rated Capacity		Weight		No. of Teeth
mm	in	L	ft ³	kg	lb	
305	12	70	2.5	127	279	3
457	18	130	4.6	146	322	4
610	24	200	7.1	174	384	5
762	30	270	9.5	197	434	5
914	36	330	11.7	224	493	6

Standard Equipment

Standard equipment may vary. Consult your Cat dealer for details.

- Adjustable auxiliary controls, backhoe loader
- Air cleaner
- Alarm, back-up
- Alternator, 150 amp
- Audible system fault alarm
- Automatic Engine Speed Control (AESC)
- Battery, maintenance-free, 880 CCA
- Battery disconnect switch
- Battery remote jumpstart
- Boom transport lock
- Brace, lift cylinder
- Brake, secondary parking
- Brakes, hydraulically boosted, oil disc, dual pedals, interlocking
- Bucket level indicator
- Canopy, ROPS/FOPS
- Cat cushion swing system
- Coat restraint
- Coolant/antifreeze, extended life
- Counterweight, bumper
- Dome light (cab only)
- Diagnostic port for engine, machine and gauge cluster Electronic Control Modules
- Differential lock, loader joystick
- Engine, Cat C4.4 ACERT (Direct Injection Turbocharged), meets Tier 4 Final emission standards, selective catalyst reduction, diesel oxidation catalyst (DOC)
- Engine enclosure, sound suppression removal panels
- Face seals, O-ring
- Fan, suction and guard
- Fast reversing shuttle, all gears
- Fenders, rear
- Filters, spin-on: fuel, engine oil, transmission oil, water separator
- Filters, bowl and cartridge: hydraulic fluid
- Flashing hazards/signal lights
- Floor mat
- Four Wheel Drive
- Fuel tank, fully enclosed
- Fully hinged front grill for cooling package cleaning access
- Gauge cluster: coolant temperature, fuel level, torque converter temperature, DEF level
- Ground level fuel fill and DEF fill
- High ambient cooling package
- Hood lock, inside cab
- Hydraulic hose, XT™
- Hydraulic oil cooler
- Hydraulic oil level sight gauge
- Hydraulic valve, hydrostatic steering
- Hydraulic valves, loader 2 function
- Hydraulic valves, backhoe 5 function
- Hydraulics, load sensing with variable displacement piston pump
- Indicator lights: Eco mode active, water in fuel, remote dial throttle active, engine warning, warning lamp, emissions module malfunction, AESC active, low battery/charging system warning, high hydraulic oil temperature; LCD warnings: engine oil pressure, machine locked (if equipped), service due, air filter blocked, high coolant temperature, auto idle shutdown, high torque converter temperature, hydraulic filter bypass
- Instrument panel lights
- Joystick controls: pilot operated, excavator-style with pattern changer
- Key start/stop system
- LCD screen: engine speed, hour meter, gear/direction, battery voltage, hydraulic oil temperature, torque converter temperature, coolant temperature, trip totals (fuel and hours), lifetime totals (fuel and hours), operator settings (units, brightness, programmable hoe auxiliary flow), service mode diagnostics, oil life reset, DPF force regeneration, maintenance intervals, ECM/system info
- Lights, working (4 front, 4 rear)
- Loader, self-leveling, return-to-dig and transmission disconnect switch
- Loader, single tilt
- Mirror, rearview
- One-touch low idle
- Open circuit breather
- Pattern changer, in cab
- Power receptacle, 12 volt, 2 internal, 1 external
- Power steering, hydrostatic
- Radio ready cab
- Seat belt, retractable, 51 mm (2 in)
- Socket, two roof
- Stabilizer shoes, street
- Steering knob
- Seat, air suspension, fabric or vinyl cover, with armrest
- Starting system, glow plugs
- Steering, hydrostatic
- Storage compartment, lockable
- Storage tray
- Stop and tail lights
- Swing transport lock
- Tilt steering wheel
- Tires
- Toolbox, external, lockable
- Torque converter
- Throttle, hand and foot, electronic
- Transmission, four speed, syncromesh
- Transmission neutralizer switch
- Transport tie-downs
- Vandalism locks, four
- Warning horn, electric

430F2/430F2 IT Optional Equipment

Optional Equipment

Optional equipment may vary. Consult your Cat dealer for details.

- Battery, additional, 880 CCA
- Cab, deluxe
- Cold weather fuel (-30° C/-22° F)
- Cold weather package, including additional battery, engine block heater, radiator antifreeze, cold weather fuel (-30° C/-22° F) and mounting for an ether bottle
- Counterweights, 115 kg (255 lb), 240 kg (530 lb) or 460 kg (1,015 lb)
- Fenders, front with integral steps
- Guard, boom protection plate
- Guard, stabilizer, rock
- Hydraulic valves, loader (3rd valve for GP, MP or Quick Coupler)
- Hydraulic valves, backhoe 6 function
- Hydraulic lines, combined function auxiliary
- Loader, IT with Quick Coupler and pilot loader control
- Product Link, satellite, PL631E
- Product Link, cellular, PL641I
- Quick Coupler, hydraulic, dual lock
- Quick Coupler, manual, dual lock
- Quick Coupler, pin lock
- Radio and CD player
- Radio and CD player, Bluetooth
- Ride Control
- Rotating beacon, magnetic mount
- Seat belt, 75 mm (3 in)
- Seat, heated
- Security system keypad
- Stabilizer pads, reversible
- Stick, extendible
- Storage box
- Transmission, AutoShift
- Transmission, AutoShift with lock-up torque converter
- Vandalism protection, gauge cover
- Work Tool Attachments such as buckets, forks, material handling arms, augers, hammers, brooms, cold planers and vibratory plate compactors. See your Cat dealer for more information.

Notes



Cat[®] 430

BACKHOE LOADER

The Cat[®] 430 Backhoe Loader delivers exceptional performance, increased fuel efficiency, superior hydraulic system, versatility and an updated operator station. The 430 feature the following:

- **Ergonomic Operator Station** – Ample legroom inside the cab makes rotating the seat simple. The air suspension seat provides comfort to the operator while roading. New backhoe control pods allow for unlimited adjustability.
- **Load Sensing Hydraulics** – The Cat Backhoe Loader's load sensing piston pump provides full hydraulic lifting and digging forces at any engine speed. Variable flow pump matches hydraulic power to work demands.
- **Machine Performance** – The Cat C3.6 engine delivers solid performance and meets U.S. EPA Tier 4 Final/EU Stage V emission standards by utilizing Selective Catalytic Reduction technology with a Diesel Oxidation Catalyst. The system allows the operator to disconnect the machine, even while the diesel exhaust fluid is being purged from the system.
- **Machine Versatility** – The all new Integrated Tool Carrier (IT Coupler) for Single Tilt Loader Arm configurations are available from the factory or for simple field installation. The Cat Backhoe Loader with Integrated Tool Carrier (IT Coupler) will be the most versatile machine on the job site providing quick connection to a variety of Cat Attachments.
- **Cat Attachments** – A large portfolio of Backhoe Loader Attachments, including but not limited to, Quick Couplers, Thumbs, assorted Buckets, and Brooms are available from the factory or for field installation. Cat Backhoe Loaders will be "Dirt Ready" upon delivery.
- **Powershift Transmission** – A Four Speed Powershift Transmission is standard to make shifting gears smooth and as simple as twisting the Powershuttle Lever.
- **Spring Applied Hydraulically Released (SAHR) Parking Brake** – The SAHR Parking Brake is activated at the push of a button and automatically engages when the machine is powered down.

Specifications

Engine

Engine	C3.6 86 kW (115 hp) Electronic Turbo Intercooled	
Ratings at 2,200 rpm		
Gross Power SAE J1995	88 kW	118 hp
Gross Power ISO 14396	86 kW	115 hp
Net Power Rating at 2,200 rpm		
SAE J1349	80 kW	107 hp
ISO 9249	80 kW	107 hp
Net Peak Power Rating @ 2,200 rpm		
SAE J1349	80 kW	107 hp
ISO 9249	80 kW	107 hp
Dimensions		
Bore	98 mm	3.86 in
Stroke	120 mm	4.72 in
Displacement	3.6 L	220 in ³
Torque Rise (net) at 1,400 rpm	40%	
SAE J1349 Net	486 N-m	358 lb-ft
Power Rating Conditions		
No de-rating required up to	3048 m	10,000 ft

- Engine meets Tier 4 Final/Stage V emission standards.

Weights*

Operating Weight* (estimated)	8188 kg	18,051 lb
Operating Weight (maximum) (ROPS capacity)	11 000 kg	24,251 lb
Operating Weight (minimum)**	7525 kg	16,590 lb
Cab, ROPS/FOPS	145 kg	320 lb
Auto-Shift Transmission	STD	STD
Ride Control	15 kg	33 lb
Air Conditioning	45 kg	99 lb
All-Wheel Drive	STD	STD
MP bucket (0.96 m ³ /1.25 yd ³)		
with fold-over forks	915 kg	2,017 lb
without fold-over forks	745 kg	1,642 lb
Loader QC	245 kg	540 lb
Extendible Stick (excludes ft. counterweight)	297 kg	655 lb
Counterweights, base	115 kg	256 lb
Stackable, one	240 kg	529 lb
Maximum	460 kg	1,014 lb

*Machine configuration: standard stick hoe, OROPS canopy, AWD powershift shift transmission, 0.96 m³ (1.25 yd³) GP (General Purpose) loader bucket, 610 mm (24 in) standard duty hoe bucket, front 340/80-18 and rear 500/70-24 tires, 460 kg (1,014 lb) counterweight, 80 kg (176 lb) operator, full fuel tank.

**Minimum weight configuration is the same as configuration above, however, excludes counterweight, hoe bucket, and operator.



430 Backhoe Loader

Transmission

Power Shift Transmission – Standard

Forward – 1st	5.9 km/h	3.7 mph
2nd	9.5 km/h	5.9 mph
3rd	20 km/h	12 mph
4th	41 km/h	26 mph
Reverse – 1st	5.9 km/h	3.7 mph
2nd	12.4 km/h	7.7 mph
3rd	27 km/h	17 mph

	Power-Shift Transmission – Optional		Power-Shift Transmission with LTC – Optional	
Forward – 1st	5.9 km/h	3.7 mph	5.9 km/h	3.7 mph
2nd	9.5 km/h	5.9 mph	9.5 km/h	5.9 mph
3rd	12 km/h	8 mph	12 km/h	8 mph
4th	20 km/h	12 mph	20 km/h	12 mph
5th	27 km/h	17 mph	27 km/h	17 mph
5th LTC	—	—	29 km/h	18 mph
6th	41 km/h	26 mph	41 km/h	26 mph
6th LTC**	—	—	40 km/h	25 mph
Reverse – 1st	5.9 km/h	3.7 mph	5.9 km/h	3.7 mph
2nd	12 km/h	7.7 mph	12 km/h	7.7 mph
3rd	27 km/h	17 mph	27 km/h	17 mph

*Travel speeds of backhoe loader at full throttle, when equipped with 500/70-24 rear tires.

**Limited by engine speed to 40 km/h (25 mph).

Axle Ratings

Front Axle, AWD

Static	23 500 kg	51,808 lb
Dynamic	9000 kg	19,841 lb

Rear Axle

Static	26 500 kg	58,422 lb
Dynamic	10 000 kg	22,046 lb

Hydraulic System

Type	Closed Center	
Pump Type	Variable-flow, Axial Piston	
Pump Capacity @ 2,200 rpm	187 L/min	49.4 gal/min
System Pressure		
Backhoe	25 000 kPa	3,626 psi
Loader	25 000 kPa	3,626 psi

Steering

Type	Front Wheel Steering	
Power Steering	Hydrostatic	
One Double-Acting Cylinder		
Bore	65 mm	2.6 in
Stroke	106 mm	4.2 in
Rod Diameter	40 mm	1.6 in
Axle Oscillation	11°	
Turning Circle – (inner wheel not braked)		
Outside front wheels	8.205 m	26'11"
Outside widest loader bucket	10.745 m	35'3"

Service Refill Capacities

Cooling System with Air Conditioning	18.0 L	4.8 gal
Fuel Tank	160.0 L	42.3 gal
Engine Oil with Filter	9.0 L	2.4 gal
Diesel Exhaust Fluid (DEF)	19.0 L	5.0 gal
Transmission – Power Shuttle		
AWD	18.0 L	4.8 gal
Transmission – Power Shift		
AWD	19.0 L	5.0 gal
Rear Axle		
Planetaries	1.7 L	0.4 gal
Front Axle (AWD)		
Planetaries	0.7 L	0.2 gal
Hydraulic System	95.0 L	25.1 gal
Hydraulic Tank	42.0 L	11.1 gal

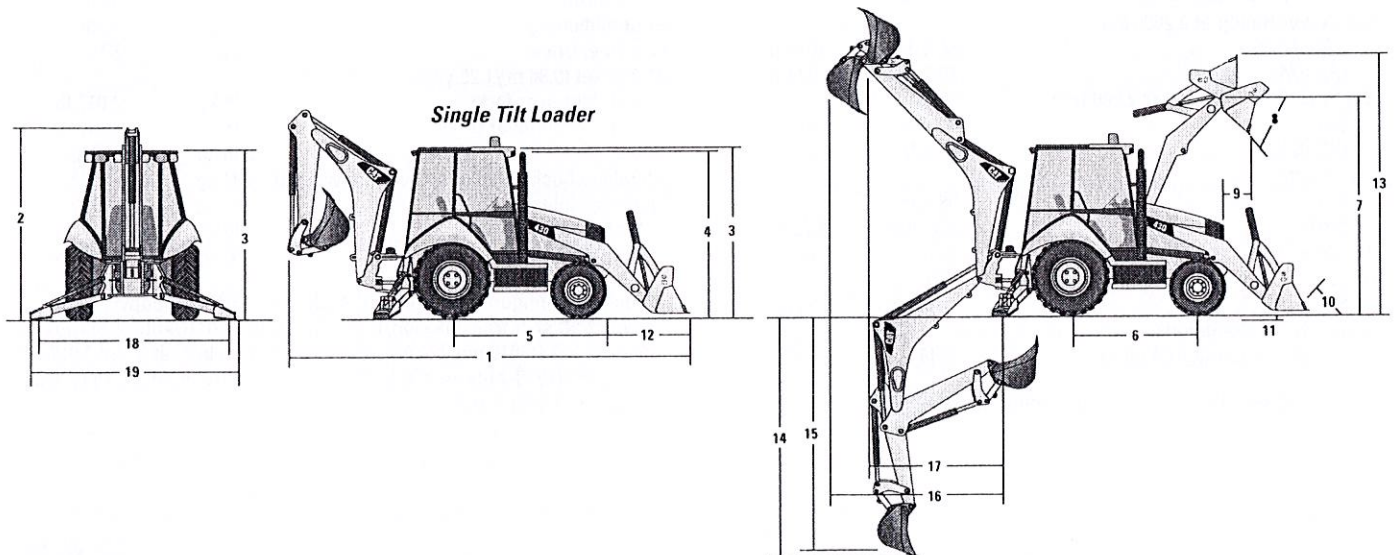

430 Backhoe Loader

Dimensions

Machine configuration: standard stick hoe, OROPS canopy, AWD power shift transmission, 0.96 m³ (1.25 yd³) GP loader bucket, 610 mm (24 in) standard duty hoe bucket, 340/80-18 and rear 500/70-24 tires, 460 kg (1,014 lb) counterweight, 80 kg (176 lb) operator, full fuel tank.

Single Tilt Loader with Pin-On Buckets

	0.96 m ³ (1.25 yd ³) GP	1.0 m ³ (1.31 yd ³) GP	1.07 m ³ (1.40 yd ³) GP	1.15 m ³ (1.50 yd ³) GP	1.0 m ³ (1.31 yd ³) MP	1.07 m ³ (1.40 yd ³) MP
1 Overall Length (loader on ground) – S-Stick – mm (ft/in)	7273 (23'10")	7228 (23'9")	7294 (23'11")	7294 (23'11")	7201 (23'8")	7201 (23'8")
Overall Length (loader on ground) – E-Stick – mm (ft/in)	7289 (23'11")	7244 (23'9")	7310 (24'0")	7310 (24'0")	7217 (23'8")	7217 (23'8")
Overall Transport Length – S-Stick – mm (ft/in)	7304 (24'0")	7271 (23'10")	7342 (24'1")	7342 (24'1")	7272 (23'10")	7272 (23'10")
Overall Transport Length – E-Stick – mm (ft/in)	7341 (24'1")	7287 (23'11")	7358 (24'2")	7358 (24'2")	7288 (23'11")	7288 (23'11")
2 Overall Transport Height – Standard Stick – mm (ft/in)	3845 (12'7")	3845 (12'7")	3845 (12'7")	3845 (12'7")	3845 (12'7")	3845 (12'7")
Overall Transport Height – Extendible Stick – mm (ft/in)	3866 (12'8")	3866 (12'8")	3866 (12'8")	3866 (12'8")	3866 (12'8")	3866 (12'8")
Overall Width – mm (ft/in)	2248 (7'5")	2248 (7'5")	2248 (7'5")	2248 (7'5")	2248 (7'5")	2248 (7'5")
3 Height to Top of Cab/Canopy – mm (ft/in)	2815 (9'3")	2815 (9'3")	2815 (9'3")	2815 (9'3")	2815 (9'3")	2815 (9'3")
4 Height to Top of Exhaust Stack – mm (ft/in)	2720 (8'11")	2720 (8'11")	2720 (8'11")	2720 (8'11")	2720 (8'11")	2720 (8'11")
Height to Loader Hinge Pin (transport) – mm (ft/in)	378 (1'3")	378 (1'3")	422 (1'5")	422 (1'5")	420 (1'5")	420 (1'5")
Ground Clearance (LH step) – mm (ft/in)	316 (1'0")	316 (1'0")	316 (1'0")	316 (1'0")	316 (1'0")	316 (1'0")
Ground Clearance (AWD guard) – mm (ft/in)	312 (1'0")	312 (1'0")	312 (1'0")	312 (1'0")	312 (1'0")	312 (1'0")
Ground Clearance (485 kg/1,070 lb counterweight) – mm (ft/in)	289 (0'11")	289 (0'11")	289 (0'11")	289 (0'11")	289 (0'11")	289 (0'11")
5 Rear Axle Centerline to Front Grill – mm (ft/in)	2706 (8'11")	2706 (8'11")	2706 (8'11")	2706 (8'11")	2706 (8'11")	2706 (8'11")
Front Wheel Tread Gauge – mm (ft/in)	1895 (6'3")	1895 (6'3")	1895 (6'3")	1895 (6'3")	1895 (6'3")	1895 (6'3")
Rear Wheel Tread Gauge – mm (ft/in)	1728 (5'8")	1728 (5'8")	1728 (5'8")	1728 (5'8")	1728 (5'8")	1728 (5'8")
6 Wheelbase – mm (ft/in)	2200 (7'3")	2200 (7'3")	2200 (7'3")	2200 (7'3")	2200 (7'3")	2200 (7'3")

Single Tilt Loader with Quick Coupler

	0.96 m ³ (1.25 yd ³) GP	1.0 m ³ (1.31 yd ³) GP	1.15 m ³ (1.50 yd ³) GP	1.0 m ³ (1.31 yd ³) MP	1.07 m ³ (1.40 yd ³) MP
1 Overall Length (loader on ground) – S-Stick – mm (ft/in)	7455 (24'5")	7410 (24'4")	7452 (24'5")	7362 (24'2")	7362 (24'2")
Overall Length (loader on ground) – E-Stick – mm (ft/in)	7471 (24'6")	7426 (24'4")	7468 (24'6")	7378 (24'2")	7378 (24'2")
Overall Transport Length – S-Stick – mm (ft/in)	7431 (24'5")	7398 (24'3")	7429 (24'4")	7360 (24'2")	7360 (24'2")
Overall Transport Length – E-Stick – mm (ft/in)	7448 (24'5")	7414 (24'4")	7446 (24'5")	7376 (24'2")	7376 (24'2")
2 Overall Transport Height – Standard Stick – mm (ft/in)	3845 (12'7")	3845 (12'7")	3845 (12'7")	3845 (12'7")	3845 (12'7")
Overall Transport Height – Extendible Stick – mm (ft/in)	3866 (12'8")	3866 (12'8")	3866 (12'8")	3866 (12'8")	3866 (12'8")
Overall Width – mm (ft/in)	2248 (7'5")	2248 (7'5")	2248 (7'5")	2248 (7'5")	2248 (7'5")
3 Height to Top of Cab/Canopy – mm (ft/in)	2815 (9'3")	2815 (9'3")	2815 (9'3")	2815 (9'3")	2815 (9'3")
4 Height to Top of Exhaust Stack – mm (ft/in)	2720 (8'11")	2720 (8'11")	2720 (8'11")	2720 (8'11")	2720 (8'11")
Height to Loader Hinge Pin (transport) – mm (ft/in)	345 (1'2")	346 (1'2")	346 (1'2")	344 (1'2")	344 (1'2")
Ground Clearance (LH step) – mm (ft/in)	316 (1'0")	316 (1'0")	316 (1'0")	316 (1'0")	316 (1'0")
Ground Clearance (AWD guard) – mm (ft/in)	312 (1'0")	312 (1'0")	312 (1'0")	312 (1'0")	312 (1'0")
Ground Clearance (485 kg/1,070 lb counterweight) – mm (ft/in)	289 (0'11")	289 (0'11")	289 (0'11")	289 (0'11")	289 (0'11")
5 Rear Axle Centerline to Front Grill – mm (ft/in)	2706 (8'11")	2706 (8'11")	2706 (8'11")	2706 (8'11")	2706 (8'11")
Front Wheel Tread Gauge – mm (ft/in)	1895 (6'3")	1895 (6'3")	1895 (6'3")	1895 (6'3")	1895 (6'3")
Rear Wheel Tread Gauge – mm (ft/in)	1728 (5'8")	1728 (5'8")	1728 (5'8")	1728 (5'8")	1728 (5'8")
6 Wheelbase – mm (ft/in)	2200 (7'3")	2200 (7'3")	2200 (7'3")	2200 (7'3")	2200 (7'3")

430 Backhoe Loader

Dimensions

Machine configuration: standard stick hoe, OROPS canopy, AWD power shift transmission, 0.96 m³ (1.25 yd³) GP loader bucket, 610 mm (24 in) standard duty hoe bucket, 340/80-18 and rear 500/70-24 tires, 460 kg (1,014 lb) counterweight, 80 kg (176 lb) operator, full fuel tank.

Loader Bucket Dimensions and Performance

	Pin-On Buckets											
	0.96 m ³ (1.25 yd ³) GP		1.0 m ³ (1.31 yd ³) GP		1.07 m ³ (1.40 yd ³) GP		1.15 m ³ (1.50 yd ³) GP		1.0 m ³ (1.31 yd ³) MP		1.07 m ³ (1.40 yd ³) MP	
Capacity (SAE rated) – m ³ (yd ³)	0.96	(1.26)	1.00	(1.31)	1.07	(1.40)	1.15	(1.50)	1.00	(1.31)	1.07	(1.40)
Overall Bucket Width – mm (in)	2262	(89)	2406	(95)	2262	(89)	2406	(95)	2279	(90)	2425	(95)
Lift Capacity at Maximum Height – kg (lb)	3280	(7,230)	3286	(7,245)	3213	(7,084)	3192	(7,038)	3059	(6,745)	3047	(6,717)
Lift Breakout Force – N (lbf)	50 179	(11,280)	50 941	(11,452)	49 644	(11,160)	49 467	(11,120)	49 114	(11,041)	49 017	(11,019)
Tilt Breakout Force – N (lbf)	49 891	(11,216)	53 037	(11,923)	50 945	(11,452)	50 834	(11,428)	56 242	(12,643)	56 166	(12,626)
Tipping Load at Breakout Point – kg (lb)	7081	(15,610)	7250	(15,983)	6976	(15,379)	6959	(15,341)	7134	(15,728)	7124	(15,707)
7 Maximum Hinge Pin Height – mm (ft/in)	3488	(11'5")	3488	(11'5")	3488	(11'5")	3488	(11'5")	3488	(11'5")	3488	(11'5")
8 Dump Angle at Full Height – degrees	44°		44°		44°		44°		44°		44°	
Dump Height at Maximum Angle – mm (ft/in)	2758	(9'1")	2790	(9'2")	2736	(9'0")	2736	(9'0")	2803	(9'2")	2803	(9'2")
9 Dump Reach at Maximum Angle – mm (ft/in)	807	(2'8")	774	(2'6")	773	(2'6")	773	(2'6")	722	(2'4")	722	(2'4")
10 Maximum Bucket Rollback at Ground Level – degrees	36°		36°		37°		37°		37°		37°	
11 Digging Depth – mm (ft/in)	70	(0'3")	70	(0'3")	110	(0'4")	110	(0'4")	97	(0'4")	97	(0'4")
Maximum Grading Angle – degrees	113°		114°		114°		114°		116°		116°	
Width of Dozer Cutting Edge – mm (ft/in)	N/A		N/A		N/A		N/A		2262	(7'5")	2406	(7'11")
12 Grill to Bucket Cutting Edge, Carry Position – mm (ft/in)	1480	(4'10")	1447	(4'9")	1518	(5'0")	1517	(5'0")	1447	(4'9")	1447	(4'9")
13 Maximum Operating Height – mm (ft/in)	4356	(14'3")	4354	(14'3")	4366	(14'4")	4397	(14'5")	4378	(14'4")	4407	(14'6")
Jaw Opening Maximum – mm (ft/in)	N/A		N/A		N/A		N/A		843	(2'9")	843	(2'9")
Bucket Jaw Clamping Force – N (lbf)	N/A		N/A		N/A		N/A		40 160	(9,028)	40 261	(9,051)
Weight (does not include teeth or forks) – kg (lb)	451	(994)	462	(1,019)	473	(1,043)	493	(1,087)	745	(1,642)	774	(1,706)

	Loader Quick Coupler									
	0.96 m ³ (1.25 yd ³) GP		1.0 m ³ (1.31 yd ³) GP		1.15 m ³ (1.50 yd ³) GP		1.0 m ³ (1.31 yd ³) MP		1.07 m ³ (1.40 yd ³) MP	
Capacity (SAE rated) – m ³ (yd ³)	0.96	(1.26)	1.00	(1.31)	1.15	(1.50)	1.00	(1.31)	1.07	(1.40)
Overall Bucket Width – mm (in)	2262	(89)	2406	(95)	2406	(95)	2279	(90)	2425	(95)
Lift Capacity at Maximum Height – kg (lb)	2879	(6,348)	2880	(6,350)	2846	(6,273)	2747	(6,057)	2711	(5,976)
Lift Breakout Force – N (lbf)	45 144	(10,148)	45 749	(10,284)	44 845	(10,081)	44 659	(10,039)	44 400	(9,981)
Tilt Breakout Force – N (lbf)	41 169	(9,255)	43 286	(9,731)	40 879	(9,190)	44 104	(9,914)	43 932	(9,876)
Tipping Load at Breakout Point – kg (lb)	6263	(13,808)	6395	(14,099)	6239	(13,754)	6379	(14,064)	6355	(14,010)
7 Maximum Hinge Pin Height – mm (ft/in)	3488	(11'5")	3488	(11'5")	3488	(11'5")	3488	(11'5")	3488	(11'5")
8 Dump Angle at Full Height – degrees	44°		44°		44°		44°		44°	
Dump Height at Maximum Angle – mm (ft/in)	2623	(8'7")	2654	(8'9")	2625	(8'7")	2690	(8'10")	2690	(8'10")
9 Dump Reach at Maximum Angle – mm (ft/in)	887	(2'11")	855	(2'10")	886	(2'11")	832	(2'9")	832	(2'9")
10 Maximum Bucket Rollback at Ground Level – degrees	37°		37°		37°		37°		37°	
11 Digging Depth – mm (ft/in)	111	(0'4")	111	(0'4")	110	(0'4")	101	(0'4")	101	(0'4")
Maximum Grading Angle – degrees	109°		110°		109°		111°		111°	
Width of Dozer Cutting Edge – mm (ft/in)	N/A		N/A		N/A		2262	(7'5")	2406	(7'11")
12 Grill to Bucket Cutting Edge, Carry Position – mm (ft/in)	1607	(5'3")	1573	(5'2")	1605	(5'3")	1535	(5'0")	1535	(5'0")
13 Maximum Operating Height – mm (ft/in)	4439	(14'7")	4406	(14'5")	4484	(14'9")	4476	(14'8")	4531	(14'10")
Jaw Opening Maximum – mm (ft/in)	N/A		N/A		N/A		843	(2'9")	843	(2'9")
Bucket Jaw Clamping Force – N (lbf)	N/A		N/A		N/A		40 185	(9,034)	40 286	(9,056)
Weight (does not include teeth or forks) – kg (lb)	447	(985)	457	(1,008)	481	(1,060)	724	(1,596)	753	(1,660)

430 Backhoe Loader

Dimensions

Machine configuration: standard stick hoe, OROPS canopy, AWD power shift transmission, 0.96 m³ (1.25 yd³) GP loader bucket, 610 mm (24 in) standard duty hoe bucket, 340/80-18 and rear 500/70-24 tires, 460 kg (1,014 lb) counterweight, 80 kg (176 lb) operator, full fuel tank.

Backhoe Dimensions and Performance

	Standard Stick		E-Stick Retracted		E-Stick Extended	
14 Digging Depth, SAE (max.) – mm (ft/in)	4612	(15'2")	4721	(15'6")	5862	(19'3")
15 Digging Depth, 2440 mm (8 ft) Flat Bottom – mm (ft/in)	4262	(14'0")	4375	(14'4")	5587	(18'4")
Digging Depth, 610 mm (2 ft) Flat Bottom – mm (ft/in)	4587	(15'1")	4693	(15'5")	5834	(19'2")
Reach from Rear Axle Centerline at Ground Line – mm (ft/in)	7122	(23'4")	7216	(23'8")	8307	(27'3")
16 Reach from Swing Pivot at Ground Line – mm (ft/in)	6032	(19'9")	6126	(20'1")	7217	(23'8")
Maximum Operating Height – mm (ft/in)	6081	(19'11")	6150	(20'2")	7038	(23'1")
Loading Height – mm (ft/in)	4027	(13'3")	3988	(13'1")	4599	(15'1")
17 Loading Reach – mm (ft/in)	1859	(6'1")	2026	(6'8")	3011	(9'11")
Swing Arc	180°		180°		180°	
Bucket Rotation	205°		204°		204°	
18 Stabilizer Spread, Operating Position (center) – mm (ft/in)	3310	(10'10")	3310	(10'10")	3310	(10'10")
Stabilizer Spread, Operating Position (outside) – mm (ft/in)	3770	(12'4")	3770	(12'4")	3770	(12'4")
Stabilizer Spread, Transport Position – mm (ft/in)	2322	(7'7")	2322	(7'7")	2322	(7'7")
Bucket Dig Force – N (lbf)	71 897	(16,163)	70 904	(15,940)	70 904	(15,940)
Stick Dig Force – N (lbf)	44 867	(10,086)	43 939	(9,878)	32 517	(7,310)

Dimensions with Forks/Material Handling Arm

Fork Tine Length	1070 mm (3'6")		1220 mm (4'0")		1370 mm (4'10")	
Operating Load (SAE J1197) – kg (lb)	1971	(4,346)	1891	(4,168)	1814	(4,000)
SAE Load Center – mm (in)	535	(1'9")	610	(2'0")	685	(2'3")
Operating Load (CEN 474-4) – kg (lb)	2004	(4,417)	1988	(4,382)	1971	(4,346)
CEN Load Center – mm (ft/in)	500	(1'8")	500	(1'8")	500	(1'8")
Overall Length (A) (forks on ground) – mm (ft/in)	7789	(25'7")	7939	(26'1")	8089	(26'6")
Reach at Ground (from grill to heel of fork) – mm (ft/in)	939	(3'1")	939	(3'1")	938	(3'1")
Maximum Reach (from grill to heel of fork) – mm (ft/in)	1524	(5'0")	1524	(5'0")	1524	(5'0")
Fork Height at Maximum Reach – mm (ft/in)	1619	(5'4")	1619	(5'4")	1619	(5'4")
Reach at Maximum Height (from grill to heel of fork) – mm (ft/in)	749	(2'5")	749	(2'5")	749	(2'5")
Maximum Fork Height – mm (ft/in)	3418	(11'3")	3418	(11'3")	3418	(11'3")
Maximum Fork Depth (below ground level) – mm (ft/in)	-38	(-1'11")	-38	(-1'10")	-39	(-1'10")

Material Handling Arm Position	Retracted		Mid-Position		Extended	
Operating Load (SAE J1197 and CEN 474-4) – kg (lb)*	1201	(2,647)	808	(1,782)	589	(1,298)
Overall Length, Maximum – mm (ft/in)	9045	(29'8")	10 045	(32'11")	11 043	(36'3")
Reach at Maximum Depth (from machine nose) – mm (ft/in)	544	(1'9")	550	(1'10")	557	(1'10")
Maximum Depth – mm (ft/in)	2618	(8'7")	3618	(11'10")	4616	(15'2")
Maximum Reach (from machine nose) – mm (ft/in)	3221	(10'7")	4221	(13'10")	5219	(17'1")
Height at Maximum Reach – mm (ft/in)	1118	(3'8")	1124	(3'8")	1130	(3'8")
Reach at Maximum Height (from machine nose) – mm (ft/in)	1783	(5'10")	2473	(8'1")	3161	(10'4")
Maximum Height – mm (ft/in)	4445	(14'7")	5169	(16'11")	5891	(19'4")

*These numbers are hydraulically limited.

430 Backhoe Loader

Backhoe Lift Capacity

Cat 430 Standard Stick

Boom Lifting	kg	lb
1	1856	4,093
2	1951	4,301
3	1923	4,240
4	1867	4,115
5	1802	3,973
6	1737	3,830
7	1674	3,692
8	1615	3,561
9	1560	3,439
10	1509	3,327
11	1464	3,227
12	1424	3,140
13	1394	3,073
14	1382	3,047
15	1461	3,222
Stick Lifting		
16	2449	5,400
17	2725	6,007
18	2841	6,264
19	2803	6,179
20	2961	6,529
21	3487	7,688

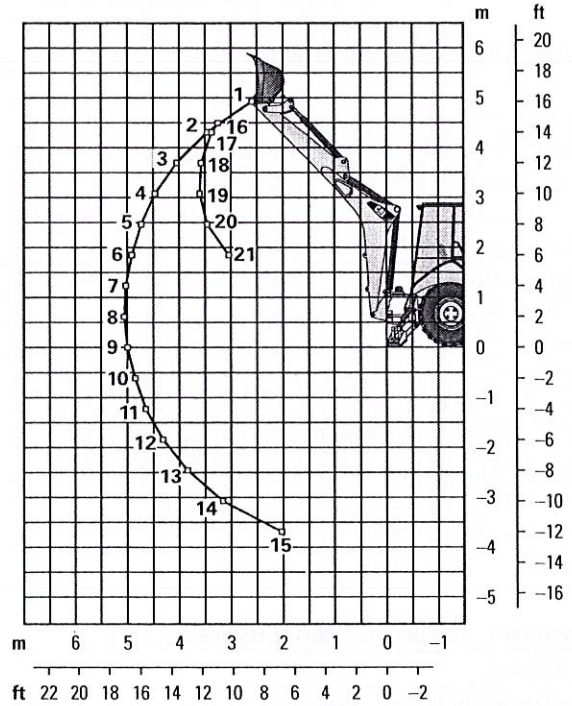

Cat 430 Extendible Stick – Retracted

Boom Lifting	kg	lb
1	1296	2,858
2	1601	3,530
3	1677	3,696
4	1651	3,640
5	1599	3,526
6	1539	3,393
7	1478	3,258
8	1418	3,126
9	1361	3,000
10	1307	2,882
11	1258	2,773
12	1213	2,673
13	1173	2,586
14	1141	2,515
15	1123	2,477
Stick Lifting		
16	2153	4,746
17	2443	5,387
18	2549	5,620
19	2514	5,542
20	2648	5,839
21	3078	6,785
22	3590	7,914

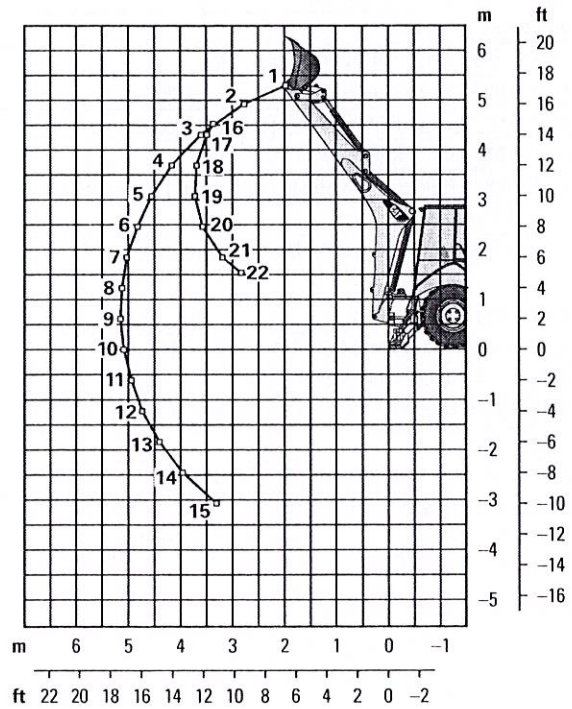

Lift capacities are over-end values calculated according to SAE J31. Values are 87% of the maximum lift force available.
 Machine equipped with AWD, OROPS, 0.96 m³ (1.25 yd³) general purpose bucket and 460 kg (1,015 lb) counterweight.
 Extendible stick includes 460 kg (1,015 lb) counterweight.

430 Backhoe Loader

Backhoe Lift Capacity

Cat 430 Extendible Stick – Extended

Boom Lifting	kg	lb
1	739	1,628
2	1050	2,314
3	1135	2,503
4	1158	2,553
5	1154	2,545
6	1138	2,509
7	1115	2,458
8	1089	2,402
9	1062	2,342
10	1036	2,283
11	1010	2,226
12	986	2,173
13	964	2,124
14	945	2,083
15	931	2,052
16	924	2,037
17	930	2,051
18	971	2,140
Stick Lifting		
19	1187	2,618
20	1306	2,880
21	1578	3,479
22	1744	3,845
23	1730	3,814
24	1774	3,911
25	1891	4,169
26	2130	4,697
27	2671	5,888

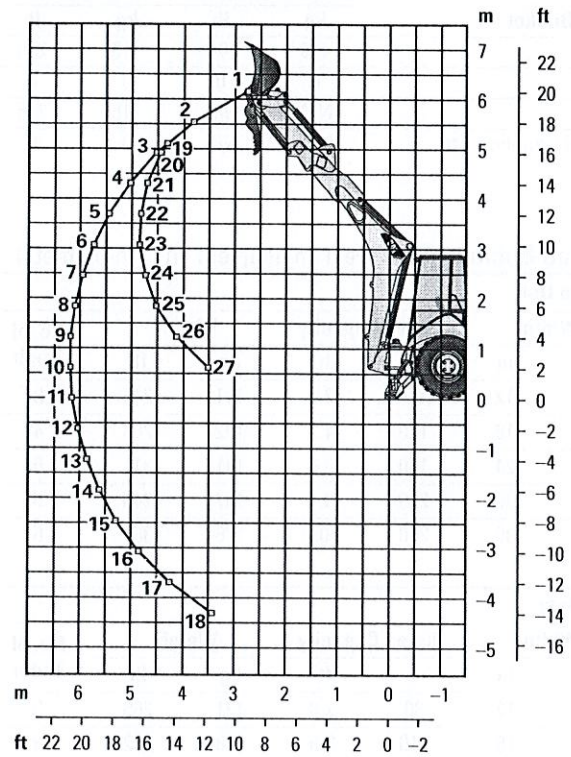

Lift capacities are over-end values calculated according to SAE J31. Values are 87% of the maximum lift force available. Machine equipped with AWD, OROPS, 0.96 m³ (1.25 yd³) general purpose bucket and 460 kg (1,015 lb) counterweight. Extendible stick includes 460 kg (1,015 lb) counterweight.

430 Backhoe Loader

Counterweights (Minimum Counterweight Recommendations)

Standard Stick Loader Bucket	Pin-On Bucket		Loader QC	
	kg	lb	kg	lb
GP	460	1,015	115	255
MP	0	0	0	0
Forks	N/A	N/A	115	255
Material Handling Arm	N/A	N/A	0	0

Extendible Stick Loader Bucket	Pin-On Bucket		Loader QC	
	kg	lb	kg	lb
GP	460	1,015	240	530
MP	240	530	0	0
Forks	N/A	N/A	240	530
Material Handling Arm	N/A	N/A	240	530

Backhoe Buckets (With weld on adapters and pin-on teeth)

Standard Duty

Width		Rated Capacity		Weight		No. of Teeth
mm	in	L	ft ³	kg	lb	
305	12	80	2.8	111	245	3
457	18	120	4.2	122	268	4
610	24	180	6.4	141	311	5
762	30	230	8.1	157	345	5
914	36	290	10.2	176	388	6

Heavy Duty

Width		Rated Capacity		Weight		No. of Teeth
mm	in	L	ft ³	kg	lb	
305	12	80	2.8	121	266	3
406	16	110	3.9	128	282	3
457	18	120	4.2	135	299	4
610	24	180	6.4	160	353	5
762	30	230	8.1	177	391	5
914	36	290	10.2	201	443	6

Soil Excavation

Width		Rated Capacity		Weight		No. of Teeth
mm	in	L	ft ³	kg	lb	
457	18	180	6.4	155	341	4
610	24	240	8.5	182	402	5
762	30	320	11.3	206	454	5
914	36	380	13.4	233	513	6

Rock

Width		Rated Capacity		Weight		No. of Teeth
mm	in	L	ft ³	kg	lb	
305	12	70	2.5	127	279	3
457	18	130	4.6	146	322	4
610	24	200	7.1	174	384	5
762	30	270	9.5	197	434	5
914	36	330	11.7	224	493	6

Coral

Width		Rated Capacity		Weight		No. of Teeth
mm	in	L	ft ³	kg	lb	
305	12	60	2.1	134	295	4
457	18	100	3.5	155	341	6
610	24	140	4.9	182	402	8
762	30	190	6.7	210	463	10

STANDARD EQUIPMENT

- Adjustable auxiliary controls, backhoe loader
- Air cleaner
- Alarm, back-up
- Audible system fault alarm
- Automatic Engine Speed Control (AESC)
- Battery, maintenance-free, 850 CCA
- Battery disconnect switch
- Boom transport lock
- Brace, lift cylinder
- Brake, parking, Spring Applied Hydraulically Released (SAHR)
- Brakes, hydraulically boosted, oil disc, dual pedals, interlocking
- Bucket level indicator
- Canopy, ROPS/FOPS
- Cat cushion swing system
- Coat restraint
- Coolant/antifreeze, extended life
- Dome light (cab only)
- Diagnostic port for engine, machine and gauge cluster Electronic Control Modules
- Differential lock, loader joystick
- Drink holders, two
- Engine, Cat C3.6 ACERT (Direct Injection Turbocharged), meets Tier 4 Final/Stage V emission standards, Selective Catalytic Reduction, Diesel Oxidation Catalyst (DOC)
- Engine enclosure, sound suppression, removable side panels
- Face seals, O-ring
- Fan, suction and guard
- Fast reversing shuttle, all gears
- Fenders, rear
- Filters, spin-on: fuel, engine oil, transmission oil, water separator
- Filters, bowl and cartridge: hydraulic fluid
- Flashing hazards/signal lights
- Floor mat
- Fuel tank, fully enclosed
- Four wheel drive
- Four wheel drive shaft guard
- Fully hinged front grill for cooling package cleaning access
- Gauge cluster: coolant temperature, fuel level, torque converter temperature, DEF level
- Ground level fuel fill and DEF fill
- Halogen lights, working (2 front, 2 rear)
- High ambient cooling package
- Hood lock, inside cab
- Hydraulic hose, XT™
- Hydraulic oil cooler
- Hydraulic oil level sight gauge
- Hydraulic valves, loader 2 function
- Hydraulic valves, backhoe 4 function
- Hydraulics, load sensing with variable displacement piston pump
- Indicator lights: wait to start, water in fuel, engine warning, warning lamp, emissions module malfunction, low battery/charging system warning, high hydraulic oil temperature: LCD warnings: engine oil pressure, machine locked, service due, air filter blocked, high coolant temperature, auto idle shutdown, high torque converter temperature, hydraulic filter bypass
- Instrument panel lights
- Joystick controls: pilot operated, excavator-style with pattern changer
- Key start/stop system
- LCD operator display with soft key controls: engine speed, hour meter, gear/direction, battery voltage, hydraulic oil temperature, torque converter temperature, coolant temperature, trip totals (fuel and hours), lifetime totals (fuel and hours), operator settings (units, brightness, programmable hoe auxiliary flow), service mode diagnostics, maintenance intervals, ECM/system info
- Loader, self-leveling, return-to-dig and transmission disconnect switch
- Loader, single tilt
- Mirror, interior, rearview
- One-touch low idle
- Open circuit breather
- Pattern changer, in cab
- Power receptacle, 5 volt USB, 1 internal
- Power receptacle, 12 volt, 2 internal, 1 external
- Power steering, hydrostatic
- Product Link™, satellite, network manager
- Product Link, cellular, network manager
- Seat belt, retractable, 51 mm (2 in)
- Socket, two roof
- Stabilizer shoes, street
- Steering knob
- Seat, air suspension, vinyl cover, with armrest
- Stabilizers, EH Control, Auto-UP
- Starting system, glow plugs
- Steering column, tilting, telescopic
- Storage compartment, lockable
- Storage tray
- Stop and tail lights
- Swing transport lock
- Tires
- Toolbox, external, lockable
- Torque converter
- Throttle, hand and foot, electronic
- Transmission, 4 speed, powershift
- Transmission neutralizer switch
- Transport tie-downs
- Vandalism locks, four
- Warning horn, electric

430 Backhoe Loader

OPTIONAL EQUIPMENT

- Auxiliary hydraulics, loader, adjustable flow
- Auxiliary hydraulics, rear, adjustable flow
- Battery, additional, 850 CCA
- Cab, deluxe
- Cold weather fuel (-30° C/-22° F)
- Cold weather package, including additional battery, engine block heater, radiator antifreeze, cold weather fuel (-30° C/-22° F) and mounting for an ether bottle
- Counterweights, 115 kg (255 lb), 240 kg (530 lb) or 460 kg (1,015 lb)
- Fenders, front with integral steps
- Guard, boom protection plate
- Guard, stabilizer, rock
- Hydraulic valves, loader with auxiliary thumb control (3rd valve for MP or Quick Coupler)
- Hydraulic valves, backhoe (5th and 6th function)
- Hydraulic lines, combined function auxiliary
- LED lights, working (2 front, 2 rear)
- Quick Coupler, hydraulic, dual lock
- Quick Coupler, manual, dual lock
- Quick Coupler, manual, pin lock
- Radio and CD player, Bluetooth®
- Ride Control
- Rotating beacon, magnetic mount
- Seat, air suspension, fabric with armrest
- Seat, air suspension, fabric with armrest, heated
- Seat belt, retractable, 75 mm (3 in)
- Security system, Bluetooth
- Security system, operator display
- Side mirrors, cab, external
- Single Tilt Loader Coupler, Integrated Tool Carrier (IT) Interface
- Stabilizer pads, reversible
- Stick, extendible
- Transmission, AutoShift with lock-up torque converter, 6 speed
- Vandalism protection, gauge cover
- Work Tool Attachments such as buckets, forks, material handling arms, augers, hammers, brooms, cold planers and vibratory plate compactors. See your Cat dealer for more information.

430 Backhoe Loader

For more complete information on Cat products, dealer services, and industry solutions, visit us on the web at www.cat.com

© 2020 Caterpillar
All rights reserved

Materials and specifications are subject to change without notice. Featured machines in photos may include additional equipment. See your Cat dealer for available options.

CAT, CATERPILLAR, LET'S DO THE WORK, their respective logos, "Caterpillar Corporate Yellow," the "Power Edge" and Cat "Modern Hex" trade dress as well as corporate and product identity used herein, are trademarks of Caterpillar and may not be used without permission.

AEHQ8245-01 (06-2020)
Replaces AEHQ8245
Build Number: 07A
(North America)



Effective with sales to the first user on or after June 1, 2015

CATERPILLAR LIMITED WARRANTY

For Selected Machine Models Designated by Caterpillar with 12 Month/Unlimited Hour Warranty

Worldwide

Caterpillar Inc. or any of its subsidiaries ("Caterpillar") warrants the following products sold by it to be free from defects in material and workmanship:

- New earthmoving, construction, material handling, forestry product, paving product, compact wheel loader, mini hydraulic excavator, skid steer loader, multi terrain loader, and compact track loader machines designated by Caterpillar as having 12-months/unlimited hour warranty. See your Cat® dealer for a complete listing of covered models.

- Attachments/work tools installed on such machines prior to delivery (unless covered by the Cat Work Tool warranty statement or another manufacturer's warranty). Hammer tool points and compacting plates used on hydraulic hammers are not warranted.

An additional warranty against breakage is applicable to certain Cat ground engaging tools. An additional warranty against wear is applicable to all landfill compactor tips when used in residential waste landfills. Refer to the applicable warranty statements for coverage detail.

This warranty does not apply to:

- Cat Batteries
- Mobil-trac belts, rubber tracks used on multi terrain loaders, compact track loaders, and mini hydraulic excavators
- Cat Work Tools
- Select models designated by Caterpillar that are sold in India and China

These products are covered by other Caterpillar warranties.

This warranty is subject to the following:

Warranty Period

For new machines and work tools/attachments the warranty period is 12-months/unlimited hours, starting from date of delivery to the first user.

Note:

- For hydraulic line's quick connect/disconnect components sold on compact wheel loaders, mini hydraulic excavators, skid steer loaders, multi terrain loaders, and compact track loader machines, the warranty period is 50 hours starting from the date of delivery to the first user.
- For Draglines, Electric Rope Shovels, Hard Rock Movers, Hard Rock Feeders; the warranty period is not to exceed 24 months from shipment of the last major component from the Caterpillar place of manufacture.

Caterpillar Responsibilities

If a defect in material or workmanship is found during the warranty period, Caterpillar will, during normal working hours and at a place of business of a Cat dealer or other source approved by Caterpillar:

- Provide (at Caterpillar's choice) new, remanufactured, or Caterpillar approved repaired parts or assembled components needed to correct the defect.

Note: New, remanufactured, or Caterpillar approved replacement parts provided under the terms of this warranty are warranted for the remainder of the warranty period applicable to the product in which installed as if such parts were original components of that product. Items replaced under this warranty become the property of Caterpillar.

- Replace lubricating oil, filters, antifreeze, and other service items made unusable by the defect.
- Provide reasonable and customary labor needed to correct the defect.

User Responsibilities

The user is responsible for:

- Providing proof of delivery date to the first user.

- Labor costs, except as stated under "Caterpillar Responsibilities."
- Transportation costs, except as stated under "Caterpillar Responsibilities."
- Premium or overtime labor costs.
- Parts shipping charges in excess of those that are considered usual and customary.
- Local taxes, if applicable.
- Costs to investigate complaints, unless the problem is caused by a defect in Caterpillar material or workmanship.
- Giving timely notice of a warrantable failure and promptly making the product available for repair.
- Performance of the required maintenance (including use of proper fuel, oil, lubricants, and coolant) and items replaced due to normal wear and tear.
- Allowing Caterpillar access to all electronically stored data.

Limitations

Caterpillar is not responsible for:

- Failures resulting from any use or installation that Caterpillar judges improper.
- Failures resulting from attachments, accessory items, and parts not sold or approved by Caterpillar.
- Failures resulting from abuse, neglect, and/or improper storage or repair.
- Failures resulting from user's delay in making the product available after being notified of a potential product problem.
- Failures resulting from unauthorized repair or adjustments, and unauthorized fuel setting changes.

(Continued on the reverse side....)

This warranty covers every major component of the products. Claims under this warranty should be submitted to a place of business of a Cat dealer or other source approved by Caterpillar. For further information concerning either the location to submit claims or Caterpillar as the issuer of this warranty, write Caterpillar Inc., 100 N. E. Adams St., Peoria, IL USA 61629.

Caterpillar's obligations under this Limited Warranty are subject to, and shall not apply in contravention of, the laws, rules, regulations, directives, ordinances, orders, or statutes of the United States, or of any other applicable jurisdiction, without recourse or liability with respect to Caterpillar.

A) For products operating outside of Australia, Fiji, Nauru, New Caledonia, New Zealand, Papua New Guinea, the Solomon Islands, and Tahiti, the following is applicable:

NEITHER THE FOREGOING EXPRESS WARRANTY NOR ANY OTHER WARRANTY BY CATERPILLAR, EXPRESS OR IMPLIED, IS APPLICABLE TO ANY ITEM CATERPILLAR SELLS THAT IS WARRANTED DIRECTLY TO THE USER BY ITS MANUFACTURER.

THIS WARRANTY IS EXPRESSLY IN LIEU OF ANY OTHER WARRANTIES, EXPRESS OR IMPLIED, INCLUDING ANY WARRANTY OF MERCHANTABILITY OR FITNESS FOR A PARTICULAR PURPOSE, EXCEPT CATERPILLAR EMISSION-RELATED COMPONENTS WARRANTY FOR NEW ENGINES, WHERE APPLICABLE. REMEDIES UNDER THIS WARRANTY ARE LIMITED TO THE PROVISION OF MATERIAL AND SERVICES, AS SPECIFIED HEREIN.

CATERPILLAR IS NOT RESPONSIBLE FOR INCIDENTAL OR CONSEQUENTIAL DAMAGES.

CATERPILLAR EXCLUDES ALL LIABILITY FOR OR ARISING FROM ANY NEGLIGENCE ON ITS PART OR ON THE PART OF ANY OF ITS EMPLOYEES, AGENTS, OR REPRESENTATIVES IN RESPECT OF THE MANUFACTURE OR SUPPLY OF GOODS OR THE PROVISION OF SERVICES RELATING TO THE GOODS.

IF OTHERWISE APPLICABLE, THE VIENNA CONVENTION ON CONTRACTS FOR THE INTERNATIONAL SALE OF GOODS IS EXCLUDED IN ITS ENTIRETY.

B) For products operating in Australia, Fiji, Nauru, New Caledonia, New Zealand, Papua New Guinea, the Solomon Islands, and Tahiti, the following is applicable:

THIS WARRANTY IS IN ADDITION TO WARRANTIES AND CONDITIONS IMPLIED BY STATUTE AND OTHER STATUTORY RIGHTS AND OBLIGATIONS THAT BY ANY APPLICABLE LAW CANNOT BE EXCLUDED, RESTRICTED OR MODIFIED ("MANDATORY RIGHTS"). ALL OTHER WARRANTIES OR CONDITIONS, EXPRESS OR IMPLIED (BY STATUTE OR OTHERWISE), ARE EXCLUDED, WITHOUT LIMITING THE FOREGOING PROVISIONS OF THIS PARAGRAPH, WHERE A PRODUCT IS SUPPLIED FOR BUSINESS PURPOSES. THE CONSUMER GUARANTEES UNDER THE CONSUMER GUARANTEES ACT 1993 (NZ) WILL NOT APPLY.

NEITHER THIS WARRANTY NOR ANY OTHER CONDITION OR WARRANTY BY CATERPILLAR, EXPRESS OR IMPLIED (SUBJECT ONLY TO THE MANDATORY RIGHTS), IS APPLICABLE TO ANY ITEM CATERPILLAR SELLS THAT IS WARRANTED DIRECTLY TO THE USER BY ITS MANUFACTURER.

IF THE MANDATORY RIGHTS MAKE CATERPILLAR LIABLE IN CONNECTION WITH SERVICES OR GOODS, THEN TO THE EXTENT PERMITTED UNDER THE MANDATORY RIGHTS, THAT LIABILITY SHALL BE LIMITED AT CATERPILLAR'S OPTION TO (a) IN THE CASE OF SERVICES, THE SUPPLY OF THE SERVICES AGAIN OR THE PAYMENT OF THE COST OF HAVING THE SERVICES SUPPLIED AGAIN AND (b) IN THE CASE OF GOODS, THE REPAIR OR REPLACEMENT OF THE GOODS. THE SUPPLY OF EQUIVALENT GOODS, THE PAYMENT OF THE COST OF SUCH REPAIR OR REPLACEMENT OR THE ACQUISITION OF EQUIVALENT GOODS.

CATERPILLAR EXCLUDES ALL LIABILITY FOR OR ARISING FROM ANY NEGLIGENCE ON ITS PART OR ON THE PART OF ANY OF ITS EMPLOYEES, AGENTS OR REPRESENTATIVES IN RESPECT OF THE MANUFACTURE OR SUPPLY OF GOODS OR THE PROVISION OF SERVICES RELATING TO THE GOODS.

CATERPILLAR IS NOT LIABLE FOR INCIDENTAL OR CONSEQUENTIAL DAMAGES UNLESS IMPOSED UNDER MANDATORY RIGHTS. IF OTHERWISE APPLICABLE, THE VIENNA CONVENTION (CONTRACTS FOR THE INTERNATIONAL SALE OF GOODS) IS EXCLUDED IN ITS ENTIRETY.

C) For products supplied in Australia:

IF THE PRODUCTS TO WHICH THIS WARRANTY APPLIES ARE:

I. PRODUCTS OF A KIND ORDINARILY ACQUIRED FOR PERSONAL, DOMESTIC OR HOUSEHOLD USE OR CONSUMPTION; OR

II. PRODUCTS THAT COST AUD 40,000 OR LESS,

WHERE THOSE PRODUCTS WERE NOT ACQUIRED FOR THE PURPOSE OF RE-SUPPLY OR FOR THE PURPOSE OF USING THEM UP OR TRANSFORMING THEM IN THE COURSE OF PRODUCTION OR MANUFACTURE OR IN THE COURSE OF REPAIRING OTHER GOODS OR FIXTURES, THEN THIS SECTION C APPLIES.

THE FOLLOWING MANDATORY TEXT IS INCLUDED PURSUANT TO THE AUSTRALIAN CONSUMER LAW AND INCLUDES REFERENCES TO RIGHTS THE USER MAY HAVE AGAINST THE DIRECT SUPPLIER OF THE PRODUCTS: OUR GOODS COME WITH GUARANTEES THAT CANNOT BE EXCLUDED UNDER THE AUSTRALIAN CONSUMER LAW. YOU ARE ENTITLED TO A REPLACEMENT OR REFUND FOR A MAJOR FAILURE AND COMPENSATION FOR ANY OTHER REASONABLY FORESEEABLE LOSS OR DAMAGE. YOU ARE ALSO ENTITLED TO HAVE THE GOODS REPAIRED OR REPLACED IF THE GOODS FAIL TO BE OF ACCEPTABLE QUALITY AND THE FAILURE DOES NOT AMOUNT TO A MAJOR FAILURE. THE INCLUSION OF THIS TEXT DOES NOT CONSTITUTE ANY REPRESENTATION OR ACCEPTANCE BY CATERPILLAR OF LIABILITY TO THE USER OR ANY OTHER PERSON IN ADDITION TO THAT WHICH CATERPILLAR MAY HAVE UNDER THE AUSTRALIAN CONSUMER LAW.

TO THE EXTENT THE PRODUCTS FALL WITHIN THIS SECTION C BUT ARE NOT OF A KIND ORDINARILY ACQUIRED FOR PERSONAL, DOMESTIC OR HOUSEHOLD USE OR CONSUMPTION, CATERPILLAR LIMITS ITS LIABILITY TO THE EXTENT IT IS PERMITTED TO DO SO UNDER THE AUSTRALIAN CONSUMER LAW TO, AT ITS OPTION, THE REPAIR OR REPLACEMENT OF THE PRODUCTS, THE SUPPLY OF EQUIVALENT PRODUCTS, OR THE PAYMENT OF THE COST OF SUCH REPAIR OR REPLACEMENT OR THE ACQUISITION OF EQUIVALENT PRODUCTS.

THE WARRANTY SET OUT IN THIS DOCUMENT IS GIVEN BY CATERPILLAR INC. OR ANY OF ITS SUBSIDIARIES, 100 N. E. ADAMS ST. PEORIA, IL USA 61629, TELEPHONE 1 309 675 1000; THE USER IS RESPONSIBLE FOR ALL COSTS ASSOCIATED WITH MAKING A CLAIM UNDER THE WARRANTY SET OUT IN THIS DOCUMENT, EXCEPT AS EXPRESSLY STATED OTHERWISE IN THIS DOCUMENT, AND THE USER IS REFERRED TO THE BALANCE OF THE DOCUMENT TERMS CONCERNING CLAIM PROCEDURES, CATERPILLAR RESPONSIBILITIES AND USER RESPONSIBILITIES.

TO THE EXTENT PERMISSIBLE BY LAW, THE TERMS SET OUT IN THE REMAINDER OF THIS WARRANTY DOCUMENT (INCLUDING SECTION B) CONTINUE TO APPLY TO PRODUCTS TO WHICH THIS SECTION C APPLIES.

©2014 Caterpillar All Rights Reserved. CAT, CATERPILLAR, their respective logos, "Caterpillar Yellow," the "Power Edge" trade dress as well as corporate and product identity used herein, are trademarks of Caterpillar and may not be used without permission.

CONTROL YOUR COSTS MINIMIZE YOUR RISKS

This plan safeguards your investments in new, used and rebuilt machines beyond the standard warranty period. It includes all parts and labor to protect you against failures caused by defects in materials and workmanship. With the Powertrain Equipment Protection Plan, you can increase the predictability of service and maintenance costs—and reduce unplanned downtime.

WHAT WE DO

- Perform necessary inspections to confirm eligibility
- Install parts approved by Caterpillar on covered repairs
- Validate your enrollment in the program

WHAT YOU DO

- Operate equipment according to the Cat Operation & Maintenance Manual (OMM)
- Have recommended preventive maintenance performed at intervals specified in the OMM
- Upon request, provide proof of preventive maintenance compliance (receipts, copies of work orders, invoices)
- Promptly provide the machine for repair in the event of a covered failure

Engine - Internal Components	Camshaft & Camshaft Bearings	Hydrostatic Pumps &
Oil Cooler	Timing / Accessory Gears	Drive Motors
Manifolds	Timing Chain / Belt	Linkage / lines Connected to
Fan Motor	Inlet / Exhaust Valve	Hystat Pump
Water Pump	Valve Cover & Base	Drive (pilot / eh) Control Valves
Fuel Injection Pumps	Valve Spring & Guide	Bevel and Transfer Case
Injectors	Rocker Arm	
Lift / Transfer Pump	Rocker Shaft Assembly	
Senders / Solenoids / Sensors	Push Rod	
Thermostat	Balancer	
Flywheel & Torque Converter	Fuel Pump / Governor Drive	
Engine Oil Filter Mount	Oil Pump	
Turbocharger	Oil Pan Group	
AC Compressor / Condenser	Fan & Fan Drive	
Electronic Control Modules		
Oil Hoses / Lines (non-hydrostatic)		
Cylinder Block		
Piston		
Piston Rings		
Piston & Connecting Rod		
Crankshaft, Main Bearings & Rod Bearings		

EXCLUSIONS

If a component is not listed, it may not be included in the plan. Other exclusions include:

- > Improper or abusive use of the machine
- > Lubricating oil, antifreeze, filters, consumables and other maintenance items replaced during the covered component repair, unless such items are rendered unusable by a covered component failure
- > Failures caused by normal wear-out
- > Freight charges for parts shipments
- > Travel time and mileage involved in getting to a job site
- > Hauling costs and / or retrieval costs
- > Overtime labor costs
- > Repair costs resulting from the failure of any non-covered components
- > Downtime loss
- > Equipment rental charges
- > Any incidental / consequential damages or costs incurred as a result of a covered component failure.
- > Modifications unless approved by Caterpillar

Examples of covered and excluded components or items are listed here. The actual dealer contract will govern. For a complete list of included components and more information on Cat Equipment Protection Plans, contact your local Cat dealer.



Click any for help

- Home
- My Cases
- New Case
- View Cases
- Search Cases
- My Profile
- Edit Profile
- Change Password
- Change Security Questions
- My Company
- Edit Company Profile
- Add New User
- View Existing Users
- Close Company Account
- My Reports
- View Reports
- My Resources
- View Essential Resources
- Take Tutorial
- View User Manual
- Contact Us

Company Information

Company Name: Thompson Tractor Co., Inc.

[View / Edit](#)

Company ID Number: 47130

Doing Business As (DBA) Name:

DUNS Number:

Physical Location:

Address 1: 2401 Pinson Highway

Address 2:

City: Birmingham

State: AL

Zip Code: 35217

County: JEFFERSON

Mailing Address:

Address 1: P O. Box 10367

Address 2:

City: Birmingham

State: AL

Zip Code: 35202-0367

Additional Information:

Employer Identification Number: 630377478

Total Number of Employees: 1,000 to 2,499

Parent Organization:

Administrator:

Organization Designation:

Employer Category:

NAICS Code: 423 - MERCHANT WHOLESALERS, DURABLE GOODS

[View / Edit](#)

Total Hiring Sites: 40

[View / Edit](#)

Total Points of Contact: 3

[View / Edit](#)

[View MOU](#)

Company ID Number: 47130

the Employer issues a tentative nonconfirmation based upon a photo non-match. The Employer will determine whether the employee contests the tentative nonconfirmation as soon as possible after the Employer receives it.

4. If the employee contests a tentative nonconfirmation issued by DHS, the Employer will provide the employee with a referral letter and instruct the employee to contact the Department through its toll-free hotline within 8 Federal Government work days.

5. If the employee contests a tentative nonconfirmation based upon a photo non-match, the Employer will provide the employee with a referral letter to DHS. DHS will electronically transmit the result of the referral to the Employer within 10 Federal Government work days of the referral unless it determines that more than 10 days is necessary.

6. The Employer agrees that if an employee contests a tentative nonconfirmation based upon a photo non-match, the Employer will send a copy of the employee's Form I-551 or Form I-766 to DHS for review by:

- Scanning and uploading the document, or
- Sending a photocopy of the document by an express mail account (furnished and paid for by DHS).

7. The Employer understands that if it cannot determine whether there is a photo match/non-match, the Employer is required to forward the employee's documentation to DHS by scanning and uploading, or by sending the document as described in the preceding paragraph, and resolving the case as specified by the Immigration Services Verifier at DHS who will determine the photo match or non-match.

ARTICLE IV

SERVICE PROVISIONS

The SSA and DHS will not charge the Employer for verification services performed under this MOU. The Employer is responsible for providing equipment needed to make inquiries. To access the E-Verify System, an Employer will need a personal computer with Internet access.

ARTICLE V

PARTIES

This MOU is effective upon the signature of all parties, and shall continue in effect for as long as the SSA and DHS conduct the E-Verify program unless modified in writing by the mutual consent of all parties, or terminated by any party upon 30 days prior written notice to the others. Any and all system enhancements to the E-Verify program by DHS or SSA, including but not limited to the E-Verify checking against additional data sources and instituting new verification procedures, will be covered under this MOU and will not cause the need for a supplemental MOU that outlines these changes. DHS agrees to train employers on all changes made to E-Verify through the use of mandatory refresher tutorials and updates to the E-Verify manual. Even

Company ID Number: 47130

**INFORMATION REQUIRED
FOR THE E-VERIFY PROGRAM**

Information relating to your Company:

Company Name: Thompson Tractor Co., Inc.

Company Facility Address: 2401 Pinson Highway
Birmingham, AL 35217

Company Alternate Address: P.O. Box 10367
Birmingham, AL 35202-0367

County or Parish: JEFFERSON

Employer Identification Number: 630377478

North American Industry
Classification Systems Code: 423

Parent Company: _____

Number of Employees: 1,000 to
2,499 Number of Sites Verified for: 5

Are you verifying for more than 1 site? If yes, please provide the number of sites verified for in each State.

- GEORGIA 5 site(s)

Information relating to the Program Administrator(s) for your Company on policy questions or operational problems:

Name: Kimberly A Stark
Telephone Number: (205) 849 - 4279 Fax Number: (205) 849 - 4565
E-mail Address: kimberlystark@thompsontractor.com

Name: Frank M Wright
Telephone Number: (205) 849 - 4267 Fax Number: (205) 849 - 4854
E-mail Address: frankwright@thompsontractor.com

Request for Taxpayer Identification Number and Certification

Give form to the requester. Do not send to the IRS.

Print or type
See Specific instructions on page 2.

Name (as shown on your income tax return) Thompson Tractor Co., Inc. DBA Thompson Power Systems, Thompson Lift Truck Co.	
Business name, if different from above and The Cat Rent Store	
Check appropriate box: <input type="checkbox"/> Individual/Sole proprietor <input checked="" type="checkbox"/> Corporation <input type="checkbox"/> Partnership <input type="checkbox"/> Limited liability company. Enter the tax classification (D=disregarded entity, C=corporation, P=partnership) ▶ <input checked="" type="checkbox"/> Exempt payee <input type="checkbox"/> Other (see instructions) ▶	
Address (number, street, and apt. or suite no.) P O Box 10367 2401 Pinson Hwy. Tarrant, AL 35217	Requester's name and address (optional)
City, state, and ZIP code Birmingham, AL 35202-0367	
List account number(s) here (optional) Lockbox Remit To: P O Box 934005, Atlanta, GA 31193-4005	

Part I Taxpayer Identification Number (TIN)

Enter your TIN in the appropriate box. The TIN provided must match the name given on Line 1 to avoid backup withholding. For individuals, this is your social security number (SSN). However, for a resident alien, sole proprietor, or disregarded entity, see the Part I Instructions on page 3. For other entities, it is your employer identification number (EIN). If you do not have a number, see *How to get a TIN* on page 3.

Note. If the account is in more than one name, see the chart on page 4 for guidelines on whose number to enter.

Social security number : : :
or
Employer identification number 63 : 0377478

Part II Certification

Under penalties of perjury, I certify that:

1. The number shown on this form is my correct taxpayer identification number (or I am waiting for a number to be issued to me), and
2. I am not subject to backup withholding because: (a) I am exempt from backup withholding, or (b) I have not been notified by the Internal Revenue Service (IRS) that I am subject to backup withholding as a result of a failure to report all interest or dividends, or (c) the IRS has notified me that I am no longer subject to backup withholding, and
3. I am a U.S. citizen or other U.S. person (defined below).

Certification Instructions. You must cross out item 2 above if you have been notified by the IRS that you are currently subject to backup withholding because you have failed to report all interest and dividends on your tax return. For real estate transactions, item 2 does not apply. For mortgage interest paid, acquisition or abandonment of secured property, cancellation of debt, contributions to an individual retirement arrangement (IRA), and generally, payments other than interest and dividends, you are not required to sign the Certification, but you must provide your correct TIN. See the Instructions on page 4.

Sign Here	Signature of U.S. person ▶ <i>Linda X. Dunbar, Controller</i>	Date ▶
------------------	---	--------

General Instructions

Section references are to the Internal Revenue Code unless otherwise noted.

Purpose of Form

A person who is required to file an information return with the IRS must obtain your correct taxpayer identification number (TIN) to report, for example, income paid to you, real estate transactions, mortgage interest you paid, acquisition or abandonment of secured property, cancellation of debt, or contributions you made to an IRA.

Use Form W-9 only if you are a U.S. person (including a resident alien), to provide your correct TIN to the person requesting it (the requester) and, when applicable, to:

1. Certify that the TIN you are giving is correct (or you are waiting for a number to be issued),
2. Certify that you are not subject to backup withholding, or
3. Claim exemption from backup withholding if you are a U.S. exempt payee. If applicable, you are also certifying that as a U.S. person, your allocable share of any partnership income from a U.S. trade or business is not subject to the withholding tax on foreign partners' share of effectively connected income.

Note. If a requester gives you a form other than Form W-9 to request your TIN, you must use the requester's form if it is substantially similar to this Form W-9.

Definition of a U.S. person. For federal tax purposes, you are considered a U.S. person if you are:

- An individual who is a U.S. citizen or U.S. resident alien,
- A partnership, corporation, company, or association created or organized in the United States or under the laws of the United States,
- An estate (other than a foreign estate), or
- A domestic trust (as defined in Regulations section 301.7701-7).

Special rules for partnerships. Partnerships that conduct a trade or business in the United States are generally required to pay a withholding tax on any foreign partners' share of income from such business. Further, in certain cases where a Form W-9 has not been received, a partnership is required to presume that a partner is a foreign person, and pay the withholding tax. Therefore, if you are a U.S. person that is a partner in a partnership conducting a trade or business in the United States, provide Form W-9 to the partnership to establish your U.S. status and avoid withholding on your share of partnership income.

The person who gives Form W-9 to the partnership for purposes of establishing its U.S. status and avoiding withholding on its allocable share of net income from the partnership conducting a trade or business in the United States is in the following cases:

- The U.S. owner of a disregarded entity and not the entity.