

BID SUBMITTAL FORM
Alabama County Joint Bid Program
BID ITEM – HEAVY DUTY DUMP CHASSIS - OPTION F

Company Name: SOUTHLAND INTERNATIONAL TRUCKS INC dba SOUTHLAND TRANSPORTATION GROUP

Address: 1563 MAXWELL BLVD
MONTGOMERY, AL 36104

Bid Submitted by: TIM BAGENTS
 (Name of company representative)

Title: SENIOR ACCOUNT MANAGER E-mail address: tbagents@southlandtransportationgroup.com

Phone: 334-832-4102 Fax: 334-832-4941

By submitting this bid, we agree:

- | | Initials |
|--|-----------|
| That the equipment model number identified below meets the bid specs for this bid item | <u>TB</u> |
| That the bid price will be honored for all counties for the period from January 1, 2023 to December 31, 2023. | <u>TB</u> |
| That the equipment will be delivered at the bid price to all counties participating in the joint bid program | <u>TB</u> |
| That the company representative listed above will be the contact person for purchasing this bid item under the joint bid program | <u>TB</u> |
| That the bid is accompanied by a current catalog or model specification document for the model number identified below | <u>TB</u> |
| That the bid is accompanied by a copy of the manufacturer's standard warranty as required in the bid specifications | <u>TB</u> |
| That the bid includes the e-verify documentation required by Alabama law | <u>TB</u> |
| That, if awarded the bid, a performance bond will be provided upon request | <u>TB</u> |
| That an option sheet with individual pricing is attached | <u>TB</u> |

Total Bid Price including options: \$ 170389.43

Equipment Model #: HX620

Description: VOCATIONAL DUMP CHASSIS

Signature of company representative submitting bid: Tim Bagents

Title: SENIOR ACCOUNT MANAGER

OPTION COST SHEET FOR HEAVY DUTY DUMP TRUCK CHASSIS OPTION F

<u>Options</u>	<u>Option Price</u>
Allison 4500-RDS-6 six speed automatic with double over drive	\$ <u>10667.00</u>
Outside aluminum wheels (6) on rear and lift axle in lieu of standard wheels.	\$ <u>0.00</u>
Dual vertical exhaust tailpipes, shall be cab mounted with bright finish heat shields and tumbuck outlet (in lieu of standard exhaust)	\$ <u>1174.00</u>
Dual cowl mounted stainless steel air cleaners in lieu of standard	\$ <u>851.00</u>

NOTE: Award will be made on the basis of the total cost of the Truck with all options included. However, a county may, at its discretion, deduct one or more of the above-referenced options from the truck, and in such event, the cost of the option as stated on the bid shall be deducted from the total cost of the trailer. There shall be no other deductions and no additions made to the trailers by the purchasing county or by the vendor.

Equipment Model #: HX620

Description: VOCATIONAL DUMP CHASSIS

Signature of company representative submitting bid: [Signature]

Title: SENior ACCOUNT MANAGER

**BID SPECIFICATIONS
FOR
HEAVY DUTY DUMP TRUCK CHASSIS - OPTION F**

GENERAL

These specifications shall be construed as the minimum acceptable standards for a heavy duty dump truck chassis. Should the manufacturer's current published data or specifications exceed these standards, the manufacturer's standards shall be considered minimum and shall be furnished. All integral parts not specifically mentioned in the scope of these specifications that are necessary to provide a complete working unit shall be furnished. Additionally, the machine offered for bid shall include all standard manufacturers' equipment.

The use of specific names or numbers in the specifications is not intended to restrict the bidder or any seller or manufacturer, but is intended solely for the purpose of indicating the type, size, and quality of equipment considered best adapted to the uses of counties participating in this joint bid.

Note all units offered for bid must be of manufacturer's current production model and must be fully compliant with EPA standards in effect at the time of manufacture.

BID SUBMITTAL FORM

Each bidder must submit his or her bid on the Bid Submittal Form included in the invitation to bid package. All written warranties to be submitted shall be attached to the Bid Submittal Form.

BID PRICE

The price bid shall include all destination charges, delivery charges, title fees, rebates and all other applicable costs and refunds.

REPLACEMENT PARTS AVAILABILITY

Parts must be available for 5 years or 500,000 miles of use for the piece of equipment bid.

WARRANTY

Bidders shall submit a copy of the manufacturer's standard warranty along with a complete explanation of the warranty with their bid. Warranty must be transferable. Warranty must include the following minimum coverage:

Basic Vehicle: 1 Year or Unlimited miles

Diesel Engine: 2 year or 250,000 miles. However, counties will have the option to purchase additional coverage (an extended warranty) if negotiated between the purchasing county and successful bidder within the first 9 months of truck purchase.

Transmission: 3 Year or 300,000 miles

Rear Carriers: 3 Year or 300,000 miles

Yes No
Page# 25 of 26
Or Attachment

ASSEMBLY AND DELIVERY

The truck chassis will be purchased for use with a 16' dump body and optional body equipment that is to be bid separate and apart from the truck chassis. The dump body company will be responsible for assembly and installation of the dump body and related optional equipment, including the cost of the same. The selling truck chassis dealer will be responsible for delivery of the chassis to the dump Body Company for installation and for delivery of the complete dump truck unit to the county following installation and assembly of the dump body and related options onto the truck chassis. Freight to and from the Dump Body Company will be included in the truck bidder's proposal. Dump body installation and assembly costs will be included in the dump body bidder's proposal.

DOT INSPECTION AND SAFETY EQUIPMENT

Prior to delivery each unit shall be DOT inspected and include the appropriate documentation and decal. In addition each unit shall be equipped with the required fire extinguisher and reflective triangle kit.

ENGINE AND RELATED COMPONENTS

Shall be an in line 6 design 15 liter, turbo charged diesel engine capable of developing 500 HP @1900 RPM with a torque rating of 1,850 lb. ft., @ 950 RPM

Yes No
Page # 5

Radiator to have a quick drain/filling option ✓

Yes No
Page # 5

Bug Screen shall be mounted between Grill and Radiator ✓

Yes No
Page # 5

Engine cooling system to have a minimum 1,325 square inches of frontal area and extended life coolant protection to -40 degrees F.

Yes No
Page # 5

Fan drive to be (2) two speed type with a manual over-ride switch dash mounted.

Yes No
Page # 5

Single horizontal exhaust system, shall be frame mounted right side under cab with bright finish muffler/tail pipe guard, and bright finish vertical turnback tail pipe. Exhaust height 10'. ✓

Yes No
Page # 12

Single canister Diesel Particulate Filter and SCR catalyst to be frame mounted right side under cab ✓

Yes No
Page # 13

Factory installed integral Engine Compression Brake. ✓

Yes No
Page # 3

Engine electronics to include shutdown capabilities for critical engine functions, Full Diagnostic capability and road limiting and cruise control feature.

Yes No
Page # 10+11

STARTING AND ELECTRICAL SYSTEM

12-Volt system fuse/circuit breaker protected ✓

Yes No
Page # 3

12V starter with soft engagement required.

Yes No
Page # 4

Minimum 160 Amp Alternator with remote voltage sensor capability to monitor battery charge and adjust alternator output accordingly. ✓

Yes No
Page # 4

Maintenance free (3) 1980 CCA batteries to be mounted in a single aluminum box with a stainless-steel bright finish cover mounted right side back of cab. ✓

Yes No
Page # 4

Cab & Chassis electrical and air lines shall be color coded and continually numbered so technicians can easily identify and trouble shoot as necessary. ✓

Yes No
Page # 14

Vehicle shall be equipped with manual reset circuit breakers on all circuits over 5 amps ✓
Where possible, except headlight and wiper motor circuits which shall be protected using Continuous reset circuit breakers to allow continued operation during a momentary Overload for trouble shooting convenience and circuit protection.

Yes No
Page # 12

Electrical Circuit breaker panel (no tools needed for access) shall be located inside ✓
cab passenger side dash to prevent exposure to corrosive elements.

Yes No
Page # 12

TRANSMISSION AND DRIVELINE

A manual ten (10) speed overdrive design, with a minimum first gear ✓
reduction of 12.94 to 1.

Yes No
Page # 12 & 16

A dash mounted transmission temperature gauge is required. ✓

Yes No
Page # 12

Spicer SPL 250 low maintenance driveshaft, with lube for life splines required ✓
for durability and low maintenance.

Yes No
Page # 3

Clutch action shall be air assisted with hydraulic actuator to lower pedal effort and reduce operator fatigue. ✓

Yes No
Page # 12

CAB EXTERIOR

119" inch BBC double sided galvanized steel conventional day cab ✓

Yes No
Page # 17 & 19

62° forward door opening for easy cab entry. Door design includes hinges located ✓
at the front edge of the door. Door latch system is removable as a module for easy repair.

Yes No
Page # 12

Cab glass to be safety tinted. ✓

Yes No
Page # 7

Cab to have chrome grab handles on both sides of the cab. ✓

Yes No
Page # 7

Cab mounting shall be air suspended on dual air bags. ✓

Yes No
Page # 6

Cab should feature:

Dual chrome air horns with snow shields, in addition to the city horn. ✓

Yes No
Page # 3 & 4

Chrome finish grill including surround and vertical accent bars with black mesh
and bug screen mounted behind grill. Stainless steel bug deflector mounted
on hood.

Yes No
Page # 5

Mirror package to include Aero pedestal bright finish heated power adjustable
mirrors with 6.5" X 14" flat glass and 6.5" X 6" convex mirrors; bright finish hood
mounted convex mirrors 7.5" X 7", right and left sides.

Yes No
Page # 8

Bright finish exterior sunshade with integral clearance / marker lights

Yes No
Page # 8

Hood shall be constructed of composite material. (No Fiberglass)

Yes No
Page # 5

Multi-piece hood construction that allows the entire side fender to be replaced
Independent of the hood.

Yes No
Page # 18

Cab and hood paint color to be selected from manufacturer's standard non-
metallic paint chart

Yes No
Page # 5

High strength double sided galvanized steel cab construction.

Yes No
Page # 19

CAB INTERIOR

Cab interior to include the following:

Storage pocket located on back wall of cab between seats

Yes No
Page # 8

Cab should have interior sun visors on both sides of cab.

Yes No
Page # 8

Cab interior trim package is to be Diamond Elite

Yes No
Page # 8

Dash features to include:

Premium level gauge cluster includes English electronic speedometer, ambient temperature gauge, engine oil temperature gauge, transmission oil temperature gauge, air application gauge, manifold pressure gauge, air cleaner restriction gauge with text message in cluster, PTO hour meter, On Board Diagnostics display of fault codes.

Yes No
Page # 7 & 8

Fresh air filter attached to air intake cover on cowl tray in front of windshield under hood.

Yes No
Page # 8

Full adjusting tilt and telescopic steering column

Yes No
Page # 3

Cab seats should be:

Driver ISRI Series 500, air suspension, high back, synthetic leather, adjustable bolsters, double chamber lumbar, heat, ventilation, inboard armrest, adjustable Shocks, suspension cover, fore/aft isolator, cushion extension, seat tilt, memory quick down

Yes No
Page # 7

Passenger National non-suspension, high back with integral headrest, synthetic leather, fixed back and underset storage

Yes No
Page # 8

Factory installed air conditioning with integral heater and defroster.

Yes No
Page # 7

AM/FM/WB/Clock/Bluetooth/USB input/Auxiliary input. CB Radio accommodation package, header mounted. Feeds from accessory side of ignition switch with power source, one antenna and base with wiring on left mirror; auxiliary CB radio speaker. Roof mounted, shark fin antenna. Two (2) 6.5" dual cone speakers mounted in doors.

Yes No
Page # 4

Additional power sources: Dash mounted 2-post terminal type power source; auxiliary power outlet (APO) & USB Port, located in instrument panel.

Yes No
Page # 4

Windshield wipers to be two (2) speed electric with washer and intermittent Feature.

Yes No
Page # 4

Power Windows & Door locks for both Driver & Passenger side shall be provided.

Yes No
Page # 8

Cab shall be equipped with overhead storage console pockets on both Driver & passenger side with retainer nets/ or doors to secure items.

Yes No
Page # 7

1-piece bonded windshield with a surface area of not less than 2385 sq.in. required for improved jobsite visibility.

Yes No
Page # 20

Windshield wiper swept surface area shall be not less than 900 sq.in for optimum visibility during inclement weather.

Yes No
Page # 12

Cab rear window shall measure not less than 52" wide for a panoramic view to the rear of the vehicle.

Yes No
Page # 22

Cab width shall be a minimum of 69.5" at Dash between A-pillars to provide adequate room for in cab mounted equipment.

Yes No
Page # 21

Cab height from Floor to roof shall be a minimum of 52.5" at edge of dash to ensure adequate head room for a variety of drivers.

Yes No
Page # 21

Measurement from center of fuel pedal to back of cab wall shall be not less than 46.75 inches, to accommodate leg room.

Yes No
Page # 21

AIR BRAKES

Air Brake system to be ABS with electronic stability and traction control with heated air dryer, Bendix AD-HF, or equal

Yes No
Page # 2

Air compressor should have 18.7CFM capacity and increased air reservoir capacity for the installation of a pusher style third axle.

Yes No
Page # 3

System to include trailer brake piping with an in-cab control valve.

Yes No
Page # 2

Rear axle brake chambers shall be located to provide "Paver" clearance.

Yes No
Page # 3

FRAME/BUMPER/FUEL TANKS

Frame rail shall be a straight channel side rail design with outer full channel reinforcement. 120,000 PSI frame rails with section modulus of 29.84 and RBM of 3,580,800.

Yes No
Page # 2 + 24

209"-211" wheelbase with a 140"-142" cab to axle optimized for dump body length.

Yes No
Page # 2

Frame tie cross member underneath the bell housing required.

Yes No
Page # 2

Front bumper Bright Finish stainless clad aluminum.

Yes No
Page # 2

Stainless Steel DEF tank cover

Yes No
Page # 6

Fuel tank to be non-polished aluminum with a minimum of 120-gallon capacity, Located under driver side door of cab.

Yes No
Page # 6

Frame rail shall be a continuous straight structural channel to simplify frame straightening in the event of a front-end collision. A Splayed Front frame rail shall not be acceptable.

Yes No
Page # 24

Heavy Duty front tow pin with 150,000 lbs. total capacity

Yes No
Page # 2

Swing type license plate holder

Yes No
Page # 2

Frame assembly shall be huck bolted in lieu of threaded bolts where possible, to minimize frame bolt re-torque service.

Yes No
Page # 23

FRONT AXLE

20,000 lb. design steel I beam front axle

Yes No
Page # 2

20,000 lb. parabolic taper leaf front springs with shock absorbers.

Yes No
Page # 2

SET BACK front axle position of 50" +/- 1" only.

Yes No
Page # 17

"S" cam design 16.5" x 6" brakes with outboard mounted drums

Yes No
Page # 3

Front wheels to be aluminum ten (10) hole hub piloted 22.5" x 12.25".

Yes No
Page # 8

Front tires to be 20 ply 425/65R22.5 radials Continental HAC3 or equal.

Yes No
Page # 8

A wide track front axle with King Pin centers greater than 71" shall be provided for improved turn angle and maneuverability.

Yes No
Page # 2

Threaded Spring bushings in lieu of rubber for service inspection.

Yes No
Page # 12

Steering system shall include dual power gears, to provide maximum torque to steering arms. A single gear and slave cylinder are not acceptable.

Yes No
Page # 3

Turn angle greater than 38 degrees in both directions with 425 Tires required for job site maneuverability and service access

Yes No
Page # 12

REAR AXLE

46,000# capacity single reduction design tandem rear axle with Lube oil pump, and driver controlled locking differentials in both FWD-RR & RR-RR axles. Axle ratio to be determined at time of order.

Yes No
Page # 6

46,000# rubber spring suspension with restrictor cans, and 8 torque rods with shocks walking beam design. Chalmers or equal. Differential locking switches for forward & rear axle on separate switches.

Yes No
Page # 6

In cab Power divider lock out valve with warning light and buzzer.

Yes No
Page # 6

"S" cam design 16.5" x 8.625" brakes with outboard drums

Yes No
Page # 3

Rear wheels to be Alum Disc (10) hole hub piloted 24.5x 8.25 inside and out.

Yes No
Page # 8

Rear tires to be 16 ply traction radials Continental HDL2 DL or equal.

Yes No
Page # 8

OPTIONS

In addition to the above options related to the tri-axle or heavy-duty dump truck chassis, the bid must also include the cost for each of the following options, itemized separately on the bid:

Furnish, as an alternate transmission to the manual 10 speed in the base bid, an Allison 4500-RDS-6 six speed automatic with double over drive.

Yes No
Page # 6

Outside aluminum wheels (6) on rear and lift axle in lieu of standard wheels.

Yes No
Page # 12

Dual vertical exhaust tailpipes, shall be cab mounted with bright finish heat shields, and tumbback outlet (in lieu of standard exhaust).

Yes No
Page # 3

Dual cowl mounted stainless steel air cleaners in lieu of standard

Yes No
Page # 5

NOTE: Award will be made on the basis of the total cost of the truck chassis with all options included. However, a county may, at its discretion, deduct the above-referenced option from the truck chassis, and in such event, the cost of the option as stated on the bid shall be deducted from the total cost of the truck chassis. There shall be no other deductions and no additions made to the truck chassis by the purchasing county or by the vendor.

Prepared For:
 ASSOCIATION OF COUNTY COMMISSIONS OF
 ALABAMA
 Patrick McDougald
 2 N JACKSON STREET 7th Floor
 MONTGOMERY, AL 36104-
 (334)263 - 7594
 Reference ID: ACCA Dump Chass

Presented By:
 SOUTHLAND TRANSPORTATION GROUP
 Tim Bagents
 1563 MAXWELL BOULEVARD
 MONTGOMERY AL 36104 -
 (334)832-4102

Thank you for the opportunity to provide you with the following quotation on a new International truck. I am sure the following detailed specification will meet your operational requirements, and I look forward to serving your business needs.

Model Profile
2024 HX620 SBA (HX620)

AXLE CONFIG: 6X4
APPLICATION: Construction Dump
MISSION: Requested GVWR: 66000. Calc. GVWR: 66000. Calc. GCWR: 140000
 Calc. Start / Grade Ability: 31.44% / 2.92% @ 55 MPH
 Calc. Geared Speed: 83.9 MPH
DIMENSION: Wheelbase: 209.00, CA: 140.00, Axle to Frame: 75.00
ENGINE, DIESEL: {Cummins X15 500 V} Productivity Series, EPA 2021, 500HP @ 1900 RPM, 1850 lb-ft Torque @ 950 RPM, 2000 RPM Governed Speed, 512 Peak HP (Max)
TRANSMISSION, AUTOMATIC: {Allison 4500 RDS} 6th Generation Controls, Wide Ratio, 6-Speed with Double Overdrive, with PTO Provision, Less Retarder, Includes Oil Level Sensor, On/Off Highway
CLUTCH: Omit Item (Clutch & Control)
AXLE, FRONT NON-DRIVING: {Meritor MFS-20-133A} Wide Track, I-Beam Type, 20,000-lb Capacity
AXLE, REAR, TANDEM: {Meritor RT-46-164P} Single Reduction, Standard Width, 46,000-lb Capacity, with Lube Oil Pump, Driver Controlled Locking Differential in Forward-Rear and Rear-Rear Axle, 200 Wheel Ends Gear Ratio: 4.56
CAB: Conventional, Day Cab
TIRE, FRONT: (2) 425/65R22.5 Load Range L HAC 3 (CONTINENTAL), 465 rev/mile, 68 MPH, All-Position
TIRE, REAR: (8) 11R24.5 Load Range H HDL2 DL ECO PLUS (CONTINENTAL), 468 rev/mile, 75 MPH, Drive
SUSPENSION, REAR, TANDEM: {Chalmers 854-46H} Walking Beam, 46,000-lb Capacity, 54" Axle Spacing, Rubber Springs, with (8) Torque Rods, Restrictor Cans
FRAME REINFORCEMENT: Full Outer C-Channel, Heat Treated Alloy Steel (120,000 PSI Yield), 10.813" x 3.892" x 0.312" (274.6mm x 98.8mm x 7.9mm), 480.0" (12192mm) OAL
PAINT: Cab schematic 100LZ
 Location 1: 9219, Winter White (Std)
 Chassis schematic N/A

<u>Code</u>	<u>Description</u>	<u>F/R Wt</u> (lbs)	<u>Tot Wt</u> (lbs)
HX62000	Base Chassis, Model HX620 SBA with 209.00 Wheelbase, 140.00 CA, and 75.00 Axle to Frame.	9444/6697	16141
1652	CROSSMEMBER, REAR Relocated to End of Frame	-7/72	65
1AMS	CROSSMEMBER, FRAME TIE for Heavy Duty	51/5	56
1AND	AXLE CONFIGURATION {Navistar} 6x4	0/0	0
	<u>Notes</u> : Pricing may change if axle configuration is changed.		
1CBU	FRAME RAILS Heat Treated Alloy Steel (120,000 PSI Yield); 10.125" x 3.580" x 0.312" (257.2mm x 90.9mm x 8.0mm); 480.0" (12192) Maximum OAL	-48/30	-18
1GBP	FRAME REINFORCEMENT Full Outer C-Channel, Heat Treated Alloy Steel (120,000 PSI Yield), 10.813" x 3.892" x 0.312" (274.6mm x 98.8mm x 7.9mm), 480.0" (12192mm) OAL	295/612	907
1LEH	LICENSE PLATE HOLDER Single Plate, Swing Type, Mounted Below Front Bumper	1/0	1
1LTE	BUMPER, FRONT Contoured, Aluminum, Stainless Steel Clad, Heavy Duty	-60/10	-50
1SAP	CROSSMEMBER, REAR, AF (1) 5-Piece	-19/84	65
1VBC	TOW PIN, FRONT Heavy Duty; 150,000-lb. Total Capacity	91/-17	74
1WXL	WHEELBASE RANGE 191" (485cm) Through and Including 236" (600cm)	105/-105	0
2ARY	AXLE, FRONT NON-DRIVING {Meritor MFS-20-133A} Wide Track, I-Beam Type, 20,000-lb Capacity	126/0	126
3AGA	SUSPENSION, FRONT, SPRING Parabolic Taper Leaf, Shackle Type, 20,000-lb Capacity, with Shock Absorbers	-26/0	-26
4091	BRAKE SYSTEM, AIR Dual System for Straight Truck Applications	0/0	0
	<u>Includes</u> : BRAKE LINES Color and Size Coded Nylon : PARKING BRAKE CONTROL Yellow Knob, Located on Instrument Panel : PARKING BRAKE VALVE For Truck : QUICK RELEASE VALVE On Rear Axle for Spring Brake Release: 1 for 4x2, 2 for 6x4 : SPRING BRAKE MODULATOR VALVE SR-7 with relay valve for 6x4/8x6		
4619	TRAILER CONNECTIONS Four-Wheel, with Hand Control Valve and Tractor Protection Valve, for Straight Truck	2/0	2
4AZS	AIR BRAKE ABS {Bendix AntiLock Brake System} 4-Channel (4 Sensor/4 Modulator) Electronic Stability Program, with Automatic Traction Control	0/0	0
4EDM	AIR DRYER {Bendix AD-HF} with Heater, Includes Pressure Protection Circuits, Safety Valve, Integral Purge Tank, Governor Pressure Settings 110 psi Cut-In/130 psi Cut-Out, Integrated PuraGuard Coalescing Filtration	0/0	0
4EXU	BRAKE CHAMBERS, REAR AXLE {Bendix EverSure} 30/30 Sqn Spring Brake	0/14	14
4EXV	BRAKE CHAMBERS, FRONT AXLE {Bendix} 24 Sqn	4/0	4
4GBM	BRAKE, PARKING Manual Push-Pull Pneumatic Parking Brake	0/0	0
4LAG	SLACK ADJUSTERS, FRONT {Gunitite} Automatic	14/0	14
4LGG	SLACK ADJUSTERS, REAR {Gunitite} Automatic	0/28	28

<u>Code</u>	<u>Description</u>	<u>F/R Wt</u> (lbs)	<u>Tot Wt</u> (lbs)
4SPA	AIR COMPRESSOR {Cummins} 18.7 CFM	0/0	0
4VKC	AIR DRYER LOCATION Mounted Inside Left Rail, Back of Cab	0/0	0
4VKK	AIR TANK LOCATION (2) Mounted Under Battery Box, Outside Right Rail, Back of Cab, Perpendicular to Rail	0/0	0
4WBX	DUST SHIELDS, FRONT BRAKE for Air Cam Brakes	10/0	10
4WDM	DUST SHIELDS, REAR BRAKE for Air Cam Brakes	0/20	20
4WDW	BRAKE CHAMBERS, POSITION on Rear/Rear Axle Located Inside Rear Tire Envelope (Meets Asphalt Spreader/Paver Clearance Requirements)	0/0	0
4WXR	DRAIN VALVE (2) {Berg} with Pull Chains, for Air Tanks	0/0	0
4XDS	BRAKES, REAR {Meritor 16.5X8.625 Q-PLUS CAST} Air S-Cam Type, Cast Spider, Fabricated Shoe, Double Anchor Pin, Size 16.5" X 8.625", 23,000-lb Capacity per Axle	0/150	150
4XDT	BRAKES, FRONT {Meritor 16.5X6 Q-PLUS CAST} Air S-Cam Type, Cast Spider, Fabricated Shoe, Double Anchor Pin, Size 16.5" X 6", 23,000-lb Capacity	33/0	33
4XEE	PARK BRAKE CHAMBERS, ADDITIONAL (2) Spring Brake Type	0/30	30
5710	STEERING COLUMN Tilting and Telescoping	0/0	0
5CBE	STEERING WHEEL 4-Spoke; 18" Dia., Black Leather Wrapped	-7/-1	-8
5PTB	STEERING GEAR (2) {Sheppard M100/M80} Dual Power	108/-12	96
6DGX	DRIVELINE SYSTEM {Dana Spicer} Service Free SPL250 Main Driveline with SPL170 Interaxle Shaft, for 6x4	4/3	7
7BES	AFTERTREATMENT COVER Polished Aluminum	8/3	11
7DXW	EXHAUST SYSTEM Horizontal Aftertreatment System, Frame Mounted Right Side Under Cab, for Dual Vertical Tail Pipes, Cab Mounted, Left Side Pipe is Non-Functional/Aesthetic Only	52/13	65
7SAP	✓ ENGINE COMPRESSION BRAKE {Cummins} Interbrake For Cummins Signature/ ISX/X15 Engines; Furnished with Engine	0/0	0
7WBB	TAIL PIPE (2) Turnback Type, Bright	-4/0	-4
7WDL	MUFFLER/TAIL PIPE GUARD (2) Bright Stainless Steel	0/0	0
7WDM	EXHAUST HEIGHT 10'	0/0	0
8000	ELECTRICAL SYSTEM 12-Volt, Standard Equipment ✓	0/0	0
	<u>Includes</u>		
	: HAZARD SWITCH Push On/Push Off, Located on Instrument Panel to Right of Steering Wheel		
	: HEADLIGHT DIMMER SWITCH Integral with Turn Signal Lever		
	: PARKING LIGHT Integral with Front Turn Signal and Rear Tail Light		
	: STARTER SWITCH Electric, Key Operated		
	: STOP, TURN, TAIL & B/U LIGHTS Dual, Rear, Combination with Reflector		
	: WINDSHIELD WIPER SWITCH 2-Speed with Wash and Intermittent Feature (5 Pre-Set Delays), Integral with Turn Signal Lever		
	: WINDSHIELD WIPERS Single Motor, Electric, Cowl Mounted		
8695	SNOW SHIELD (2) Chrome; for Dual Air Horns	1/0	1
8836	HORN, AIR (2) Single Bell, Organ Tone, Extra Long, Chrome	4/0	4

<u>Code</u>	<u>Description</u>	<u>F/R Wt</u> (lbs)	<u>Tot Wt</u> (lbs)
8GGG	ALTERNATOR {Delco Remy 36SI} Brushless, 12 Volt, 165 Amp Capacity, Pad Mount, with Remote Sense	7/0	7
8HAE	BODY BUILDER WIRING Rear of Frame; Includes Sealed Connectors for Tail/ Amber Turn/Marker/ Backup/Accessory Power/Ground and Sealed Connector for Stop/Turn	3/0	3
8MSG	BATTERY SYSTEM {Fleetrite} Maintenance-Free, (3) 12-Volt 1980CCA Total, Top Threaded Stud	0/0	0
8RBZ	SPEAKER, AUXILIARY, CB RADIO with Jack for CB; Mounted Left Side Above Driver's Door	0/0	0
8RMV	SPEAKERS (2) 6.5" Dual Cone Mounted in Doors	0/0	0
8RNB	CB RADIO Accommodation Package, Header Mounted, Feeds from Accessory Side of Ignition Switch, Includes Power Source, One Antenna and Antenna Base with Wiring on Left Side Mirror	0/0	0
8RPB	RADIO, AUXILIARY CONTROLS Mounted in Steering Wheel, Radio Function Control Switch, Includes Volume Up/Down, Mute, Forward/Back and Bluetooth Answer/Disconnect	9/1	10
8RPP	ANTENNA Shark Fin, Roof Mounted	1/0	1
8RPS	RADIO AM/FM/WB/Clock/Bluetooth/USB Input/Auxiliary Input	3/0	3
8TMG	TRAILER CONNECTION SOCKET {Phillips} 7-Way, Mounted at Rear of Frame, Wired for Turn Signals Combined with Stop, Compatible with Trailers with Combined Stop, Tail, Turn Lamps	0/0	0
8TPR	STOP, TURN, TAIL & B/U LIGHTS {Weldon} Multi-Function LED Lamp, Mounted Outside Rails, Includes LED License Plate Light	0/5	5
8VAY	HORN, ELECTRIC Disc Style	0/0	0
8VUK	BATTERY BOX Aluminum, with Plastic Cover, 18" Wide, 2-4 Battery Capacity, Mounted Right Side Back of Cab	0/0	0
8WCK	POWER SOURCE, TERMINAL TYPE 2-Post	0/0	0
8WEZ	TURN SIGNAL SWITCH Self-Canceling	0/0	0
8WRB	HEADLIGHTS ON W/WIPERS Headlights Will Automatically Turn on if Windshield Wipers are turned on	0/0	0
8WWD	BATTERY BOX COVER Stainless Steel, Bright Finish	6/4	10
8WXB	HEADLIGHT WARNING BUZZER Sounds When Head Light Switch is on and Ignition Switch is in "Off" Position	0/0	0
8WXG	STARTING MOTOR {Mitsubishi Electric Automotive America 105P} 12-Volt, with Soft-Start	0/0	0
8XAH	CIRCUIT BREAKERS Manual-Reset (Main Panel) SAE Type III with Trip Indicators, Replaces All Fuses	0/0	0
8XHR	POWER SOURCE, ADDITIONAL Auxiliary Power Outlet (APO) with USB Port, Located in the Instrument Panel	1/0	1
8XNZ	HEADLIGHTS Halogen, with Daytime Running Lights	0/0	0
9585	FENDER EXTENSIONS Rubber	18/0	18
9AAB	LOGOS EXTERIOR Model Badges	0/0	0

<u>Code</u>	<u>Description</u>	<u>F/R Wt</u> (lbs)	<u>Tot Wt</u> (lbs)
9AAE	LOGOS EXTERIOR, ENGINE Badges	0/0	0
9ASE	FRONT END Tilting, Composite ✓	0/0	0
9HCN	GRILLE Chrome Vertical Accent Bars, with Black Mesh	0/0	0
9WAC	BUG SCREEN Mounted Behind Grille	5/0	5
9WBD	BUG DEFLECTOR Stainless Steel, Mounted on Hood	5/0	5
10060	PAINT SCHEMATIC, PT-1 Single Color, Design 100	0/0	0
10761	PAINT TYPE Base Coat/Clear Coat, 1-2 Tone	0/0	0
10AGB	COMMUNICATIONS MODULE Telematics Device with Over the Air Programming; Includes Five Year Data Plan and International 360	0/0	0
10SLV	PROMOTIONAL PACKAGE Government Silver Package	0/0	0
10WCY	SAFETY TRIANGLES	5/1	6
11001	CLUTCH Omit Item (Clutch & Control)	-126/-18	-144
12703	ANTI-FREEZE Red, Extended Life Coolant; To -40 Degrees F/ -40 Degrees C, Freeze Protection	0/0	0
12864	BLOCK HEATER, ENGINE {Phillips} 120V/1500W <u>Includes</u> : BLOCK HEATER SOCKET Receptacle Type; Mounted below Drivers Door	2/0	2
12ETN	ENGINE, DIESEL {Cummins X15 500 V} Productivity Series, EPA 2021, 500HP @ 1900 RPM, 1850 lb-ft Torque @ 950 RPM, 2000 RPM Governed Speed, 512 Peak HP (Max)	623/54	677
12THT	FAN DRIVE {Horton Drivemaster} Two-Speed Type, Direct Drive, with Residual Torque Device for Disengaged Fan Speed <u>Includes</u> : FAN Nylon	0/0	0
12VBA	AIR CLEANER Dual, Polished Stainless Steel, One Mounted on Each Side of Cowl Ahead of The Doors	32/4	36
12VHZ	EMISSION, CALENDAR YEAR {Cummins X15} EPA, OBD and GHG Certified for Calendar Year 2022	0/0	0
12WBR	FAN OVERRIDE Manual; with Electric Switch on Instrument Panel, (Fan On with Switch On)	2/0	2
12WCX	HOSE CLAMPS, RADIATOR HOSES {Gates} Shrink Band Type	0/0	0
12WTA	FAN DRIVE SPECIAL EFFECTS Fan Cooling Ring with Fan Shroud Effects, Engine Mounted	0/0	0
12WYZ	RADIATOR DRAIN & FILL FITTING SPECIAL; To Vacuum Out or Fill the Cooling System from the Bottom of Radiator, for Use with Quick-Connect Radiator Drain Tool or Shop Coolant Evacuation-Fill System	0/0	0
12WZE	CARB IDLE COMPLIANCE Federal, Does Not Comply with California Clean Air Idle Regulations	0/0	0
12XBC	RADIATOR Aluminum, Welded, Down Flow, Front to Back System, 1325 SqIn, with 806 SqIn Charge Air Cooler <u>Includes</u>	0/0	0

<u>Code</u>	<u>Description</u>	<u>F/R Wt</u> (lbs)	<u>Tot Wt</u> (lbs)
	: RADIATOR HOSES Premium, Rubber		
12XCS	CARB EMISSION WARR COMPLIANCE Federal, Does Not Comply with CARB Emission Warranty	0/0	0
13BEK	TRANSMISSION, AUTOMATIC {Allison 4500 RDS} 6th Generation Controls, Wide Ratio, 6-Speed with Double Overdrive, with PTO Provision, Less Retarder, Includes Oil Level Sensor, On/Off Highway	0/0	0
13WCU	OIL COOLER, AUTO TRANSMISSION {Modine} Remote Mounted; Not for use with Retarder	42/-6	36
13WET	TRANSMISSION SHIFT CONTROL Column Mounted Stalk Shifter, Not for Use with Allison 1000 & 2000 Series Transmission	1/0	1
13WLM	TRANSMISSION OIL Synthetic; 63 thru 76 Pints	0/0	0
13WUC	ALLISON SPARE INPUT/OUTPUT for Rugged Duty Series (RDS) and Regional Haul Series (RHS), General Purpose Trucks, Construction, Package Number 223	0/0	0
13WVV	NEUTRAL AT STOP Allison Transmission Shifts to Neutral When Service Brake is Depressed and Vehicle is at Stop; Remains in Neutral Until Service Brake is Released	0/0	0
13WYU	SHIFT CONTROL PARAMETERS {Allison} 3000 or 4000 Series Transmissions, Performance Programming	0/0	0
13XAA	PTO CONTROL, DASH MOUNTED For Customer Provided PTO; Includes Switch, Electric/Air Solenoid, Piping and Wiring	0/0	0
14862	PDL WARNING BUZZER Power Divider Lock	0/0	0
14HRE	AXLE, REAR, TANDEM {Meritor RT-46-164P} Single Reduction, Standard Width, 46,000-lb Capacity, with Lube Oil Pump, Driver Controlled Locking Differential in Forward-Rear and Rear-Rear Axle, 200 Wheel Ends . Gear Ratio: 4.56	0/514	514
14UZU	SUSPENSION, REAR, TANDEM {Chalmers 854-46H} Walking Beam, 46,000-lb Capacity, 54" Axle Spacing, Rubber Springs, with (8) Torque Rods, Restrictor Cans	0/-11	-11
14WBN	DIFF. SWITCH CONTROLS Two Independent Switches for Control Traction Differentials on Tandem Rear Axles, Mounted on Dash	1/0	1
14WBU	SHOCK ABSORBERS, REAR (4) for Chalmers Suspension Only, Mounted from Frame to Beam	0/24	24
14WMK	AXLE, REAR, LUBE {EmGard FE-75W-90} Synthetic Oil; 65 thru 89.99 Pints	0/0	0
15BAA	DEF TANK COVER Stainless Steel	3/0	3
15LKX	FUEL/WATER SEPARATOR {Davco Fuel Pro 382} 12 VDC Electric Heater, Includes Pre-Heater, Includes Water-in-Fuel Sensor	3/0	3
15LNA	FUEL HEATER {Cummins} Plumbing for Thermal Recirculation Valve (TRV) Mounted to Cummins X15 Engines, Thermostatically Controlled	0/0	0
15SMZ	FUEL TANK Non-Polished Aluminum, 24" Dia, 120 US Gal (454L), Mounted Left Side, Under Cab	22/40	62
15WDR	DEF TANK 10.6 US Gal (40L) Capacity, Frame Mounted Outside Left Rail, Under Cab	0/0	0
16030	CAB Conventional, Day Cab	0/0	0
	<u>Includes</u> : CAB REAR SUSPENSION Air		

<u>Code</u>	<u>Description</u>	<u>F/R Wt</u> (lbs)	<u>Tot Wt</u> (lbs)
	: CLEARANCE/MARKER LIGHTS (5) LED Roof Mounted : COAT HOOK, CAB Located on Rear Wall, Centered Above Rear Window : CONSOLE, CENTER Includes Two Cup Holders and One Additional Storage Area : CONSOLE, OVERHEAD Molded Plastic with Dual Storage Pockets, Retainer Nets and CB Radio Pocket; Located Above Driver and Passenger : COURTESY LIGHT (2) Driver and Passenger Door Mounted : DOME LIGHT, CAB Rectangular, Door and Instrument Panel Mounted Switch Activated, Timed Theater Dimming, Center Mounted, Integral to Console : FLOOR COVERING Rubber, Black : GLASS, ALL WINDOWS Tinted : GRAB HANDLE, CAB INTERIOR (1) "A" Pillar Mounted, Passenger Side : GRAB HANDLE, CAB INTERIOR (4) "B" Pillar and Door Mounted, Two Each Side : READING LIGHT, CAB Located in Overhead Console : STORAGE POCKET, DOOR (2) Full Length, Driver and Passenger Door		
16564	HEATER SHUT-OFF VALVES (1) Ball Valve Type, Supply Line	5/0	5
16BAM	AIR CONDITIONER with Integral Heater and Defroster	0/0	0
	<u>Includes</u> : HOSE CLAMPS, HEATER HOSE Mubea Constant Tension Clamps		
16GEG	GAUGE CLUSTER Premium Level; English with English Electronic Speedometer	0/0	0
	<u>Includes</u> : GAUGE CLUSTER DISPLAY: Base Level (3" Monochromatic Display), Premium Level (5" LCD Color Display); Odometer, Voltmeter, Diagnostic Messages, Gear Indicator, Trip Odometer, Total Engine Hours, Trip Hours, MPG, Distance to Empty/ Refill for : GAUGE CLUSTER Speedometer, Tachometer, Engine Coolant Temp, Fuel Gauge, DEF Gauge, Oil Pressure Gauge, Primary and Secondary Air Pressure : WARNING SYSTEM Low Fuel, Low DEF, Low Oil Pressure, High Engine Coolant Temp, Low Battery Voltage (Visual and Audible), Low Air Pressure (Primary and Secondary)		
16HCS	GAUGE, TEMPERATURE, AMBIENT Sensor Wiring with Display Unit Mounted in Cluster	0/0	0
16HGG	GAUGE, OIL TEMP, ENGINE	1/0	1
16HGH	GAUGE, OIL TEMP, AUTO TRANS for Allison Transmission	1/0	1
16HGN	GAUGE, AIR APPLICATION	1/0	1
16HKB	GAUGE, MANIFOLD PRESSURE Data Link Driven; Mounted in Instrument Panel, Includes Controller Module	0/0	0
16HKC	GAUGE, AIR CLEANER RESTRICTION {Filter-Minder} Under Hood Cleaner Mounted with Internal Switch, with Text Message in Cluster	0/0	0
16HKT	IP CLUSTER DISPLAY On Board Diagnostics Display of Fault Codes in Gauge Cluster	0/0	0
16HLR	VIRTUAL GAUGE, AIR APPLICATION Requires Premium Cluster	0/0	0
16LWU	SEAT, DRIVER {ISRI} Series 500, Air Suspension, High Back, Synthetic Leather, Adjustable Bolsters, Double Chamber Lumbar, Heat, Ventilation, Inboard Armrest, Adjustable Shocks, Suspension Cover, Fore/Aft Isolator, Cushion Extension, Seat Tilt, Memory Quickdown	0/0	0
16SDC	GRAB HANDLE, EXTERIOR (2) Chrome, Towel Bar Type, with Anti-Slip Rubber Inserts, for Cab Entry Mounted Left and Right Side at B-Pillar	6/0	6

<u>Code</u>	<u>Description</u>	<u>F/R Wt</u> (lbs)	<u>Tot Wt</u> (lbs)
16SNV	MIRRORS (2) Aero Pedestal, Power Adjust, Heated, Turn Signals, Bright Heads, Black Arms, 6.5" x 14" Flat Glass, Includes 6.5" x 6" Convex Mirrors, for 102" Load Width <u>Notes</u> : Mirror Dimensions are Rounded to the Nearest 0.5"	0/0	0
16SNY	MIRROR, CONVEX, HOOD MOUNTED (2) Right and Left Sides, Bright, 7.5" x 7"	11/-1	10
16SRL	SEAT, PASSENGER {National} Non Suspension, High Back with Integral Headrest, Synthetic Leather, with Fixed Back, with Under Seat Storage	30/10	40
16UZJ	STORAGE, REAR WALL Storage Pocket, Located on Back Wall Between Driver and Passenger Seats	3/0	3
16VVB	CAB INTERIOR TRIM Diamond Elite, for Day Cab <u>Includes</u> : DOOR TRIM, INTERIOR Bright Handle : INSTRUMENT PANEL TRIM Black with Woodgrain Accent, Black Gauges with Chrome Bezels : SUN VISOR (4) Padded Vinyl, 2 Moveable (Front-to-Side) Primary Visors and 2 Flip-down Auxiliary Visors; Vanity Mirrors and Toll Ticket Straps Driver and Passenger Sides	0/0	0
16WJU	WINDOW, POWER (2) and Power Door Locks, Left and Right Doors, Includes Express Down Feature	0/0	0
16WLM	HOURLMETER, PTO for Customer Provided PTO; with Indicator Light and Hourmeter in Gauge Cluster Includes Return Wire for PTO Feedback Switch	2/0	2
16WLS	FRESH AIR FILTER Attached to Air Intake Cover on Cowl Tray in Front of Windshield Under Hood	0/0	0
16XBZ	MODESTY PANEL Painted Body Color, with Amber Lens LED Lights, for Day Cab	0/0	0
16XJP	INSTRUMENT PANEL Wing Panel	0/0	0
16XTM	ACCESS, CAB Aluminum, Driver & Passenger Sides, Two Steps per Door, for use with Day Cab or Sleeper Cab	0/0	0
16XWE	SUNSHADE, EXTERIOR Bright Finish, with Integral Clearance/Marker Lights	20/1	21
27DBA	WHEELS, FRONT {Accuride 29374} DISC; 22.5x12.25 Rims, Extra Polish Aluminum, 10-Stud, 285.75mm BC, Hub-Piloted, Flanged Nut, with Steel Hubs	0/0	0
28DWJ	WHEELS, REAR {Accuride 42362} DUAL DISC; 24.5x8.25 Rims, Standard Polish Aluminum, 10-Stud, 285.75mm BC, Hub-Piloted, Flanged Nut, with Steel Hubs	0/-136	-136
29WLK	WHEEL BEARING, FRONT, LUBE {EmGard FE-75W-90} Synthetic Oil	0/0	0
7384225425	(8) TIRE, REAR 11R24.5 Load Range H HDL2 DL ECO PLUS (CONTINENTAL), 468 rev/mile, 75 MPH, Drive	0/224	224
7752665441	(2) TIRE, FRONT 425/65R22.5 Load Range L HAC 3 (CONTINENTAL), 465 rev/mile, 68 MPH, All-Position	132/0	132
Services Section:			
40132	WARRANTY Standard for HX520, HX620, Effective with Vehicles Built January 1, 2021 or Later, CTS-2015B	0/0	0
Total Component Weight:		11062/8346	19408

(0012ETN)

ATTACHMENTS: 0012WBR 0012THT 0007SAP 0016BAM

<u>Parameter</u>	<u>Value</u>	<u>UOM</u>
Max Accelerator Vehicle Speed	68	MPH
Road Speed Governor Upper Droop	0	MPH
Road Speed Governor Lower Droop	3	MPH
Driver Initiated Override (DIO)	N, DISABLE FEATURE OR FUNCTION	N/A
DIO Maximum Road Speed Delta	3	MPH
DIO Maximum Distance	30	MILES
Max Engine Speed No Veh Speed Sensr	1597	RPM
Road Speed Governor Type	1, TRADITIONAL	N/A
Fuel Economy Adjustment Factor	0, BALANCED FUEL ECONOMY	N/A
Gear Down Protection Enable	Y, ENABLE FEATURE OR FUNCTION	N/A
GDP - Heavy Load Vehicle Speed	62	MPH
GDP - Light Load Vehicle Speed	57	MPH
Driver Reward Enable	N, DISABLE FEATURE OR FUNCTION	N/A
Driver Reward Mode	2, ROAD SPEED GOVERNOR & CRUISE CONTROL	N/A
Fuel Economy - Expected Level	7.00	MPG
Fuel Economy - Good Level	7.25	MPG
Fuel Economy - Best Level	7.50	MPG
% Idle Time - Expected Level	20	%
% Idle Time - Good Level	15	%
% Idle Time - Best Level	10	%
Speed Reward - Expected Level	0	MPH
Speed Reward - Good Level	0	MPH
Speed Reward - Best Level	0	MPH
Speed Reward - Penalty Level	0	MPH
Idle Speed Adjustment Enable	N, DISABLE FEATURE OR FUNCTION	N/A
Low Idle Speed	600	RPM
Idle Shutdown Enable	N, DISABLE FEATURE OR FUNCTION	N/A
ISD Time Before Shutdown	5.0	MIN
ISD Percent Engine Loading	50	%
ISD In PTO	N, DISABLE FEATURE OR FUNCTION	N/A
ISD Manual Override	N, DISABLE FEATURE OR FUNCTION	N/A
ISD With Parking Brake Set	N, DISABLE FEATURE OR FUNCTION	N/A
ISD Ambient Temperature Override	N, DISABLE FEATURE OR FUNCTION	N/A
ISD Cold Ambient Air Temperature	30	F
ISD Intermediate Ambient Air Temp	40	F
ISD Hot Ambient Air Temperature	81	F
ISD Manual Override Inhibit Zone En	N, DISABLE FEATURE OR FUNCTION	N/A
ISD Hot Ambient Automatic Override	Y, ENABLE FEATURE OR FUNCTION	N/A
ISD Engine Coolant Temp Threshold	53	F
Cruise Control Enable	Y, ENABLE FEATURE OR FUNCTION	N/A
CC Maximum Vehicle Speed	68	MPH
CC Save Set Speed	N, DISABLE FEATURE OR FUNCTION	N/A
CC Upper Droop	0.0	MPH
CC Lower Droop	3.0	MPH
CC Auto Resume	N, DISABLE FEATURE OR FUNCTION	N/A
CC Ovrspd Retard Activation Enable	Y, ENABLE FEATURE OR FUNCTION	N/A
CC Overspeed for Max Retarder	5.0	MPH
CC Overspeed for Min Retarder	3.0	MPH
CC Engine Brake Swtch Bypass Enable	N, DISABLE FEATURE OR FUNCTION	N/A
Retarder - Min Vehicle Speed	2	MPH
Retarder - Delay Time	1.0	SEC
Retarder - Service Brake Activation	Y, ENABLE FEATURE OR FUNCTION	N/A
Force Fan On With Retarder	N, DISABLE FEATURE OR FUNCTION	N/A
Engine Fan Min On Time For AC	30	SEC
Remote Accelerator Enable	N, DISABLE FEATURE OR FUNCTION	N/A

Remote Accelerator Mode	1, REMOTE ACCELERATOR PEDAL OR LEVER WITH TRANS VERIFICATION	N/A
PTO Enable	N, DISABLE FEATURE OR FUNCTION	N/A
PTO In Cab Mode	Y, ENABLE FEATURE OR FUNCTION	N/A
Remote PTO Enable	N, DISABLE FEATURE OR FUNCTION	N/A
Remote Station PTO Enable	N, DISABLE FEATURE OR FUNCTION	N/A
PTO Max Engine Speed	2000	RPM
PTO Min Engine Speed	600	RPM
PTO Maximum Engine Load	800	LB-FT
PTO Max Vehicle Speed	2	MPH
PTO Accelerator Override	N, DISABLE FEATURE OR FUNCTION	N/A
PTO Accel Override Max Engine Speed	2030	RPM
PTO Clutch Override	N, DISABLE FEATURE OR FUNCTION	N/A
PTO Service Brake Override	Y, ENABLE FEATURE OR FUNCTION	N/A
PTO Parking Brake Interlock Mode	3, PTO PRK BRK INT TYPE SET TO ALL	N/A
PTO Transmission Neutral Interlock	N, DISABLE FEATURE OR FUNCTION	N/A
PTO Eng Spd Limit w/VSS Limit	N, DISABLE FEATURE OR FUNCTION	N/A
PTO Ignore Vehicle Speed Sensor	N, DISABLE FEATURE OR FUNCTION	N/A
PTO Resume Switch Speed	925	RPM
PTO Set Switch Speed	850	RPM
PTO Additional Switch Speed	1000	RPM
PTO Ramp Rate	100	RPM/SEC
Remote PTO Number of Speed Settings	1	N/A
Remote PTO Speed Setting 1	600	RPM
Remote PTO Speed Setting 2	600	RPM
Remote PTO Speed Setting 3	600	RPM
Remote PTO Speed Setting 4	600	RPM
Remote PTO Speed Setting 5	600	RPM
Remote Station PTO Resume Sw Spd	750	RPM
Remote Station PTO Set Switch Speed	700	RPM
Remote Station PTO Addition Sw Spd	800	RPM
Transmission Driven PTO	N, DISABLE FEATURE OR FUNCTION	N/A
Transmission Driven PTO Type	2, TRANSMISSION DRIVEN IRREGULAR LOAD	N/A
Powertrain Protection Enable	N, DISABLE FEATURE OR FUNCTION	N/A
Max Torque Allow By Axle/Driveshaft	32744	LB-FT
Max Torque in Top Gear Range	5000	LB-FT
Max Torque in Int. Gear Range	5000	LB-FT
Max Torque in Low Gear Range	5000	LB-FT
Max Torque w/o Vehicle Speed	5000	LB-FT
Lowest Gear of Top Gear Range	2.00	N/A
Lowest Gear of Int. Gear Range	10.00	N/A
Lowest Gear of Low Gear Range	16.00	N/A
Engine Protection Shutdown	Y, ENABLE FEATURE OR FUNCTION	N/A
Engine Protection Restart Inhibit	Y, ENABLE FEATURE OR FUNCTION	N/A
Engine Prot Coolant Level Shutdown	Y, ENABLE FEATURE OR FUNCTION	N/A
Sudden Veh Speed Decel Threshold	6.96	MPH
Trip Information Vehicle Ovrsped1	75	MPH
Trip Information Vehicle Ovrsped2	77	MPH
Veh Speed Sensor Anti Tamper Level	1, HIGH LEVEL	N/A
Maintenance Monitor Enable	N, DISABLE FEATURE OR FUNCTION	N/A
Maintenance Monitor Operating Mode	0, MAINTENANCE MONITOR AUTOMATIC MODE OF OPERATION	N/A
Maintenance Monitor Alert Percent	90	%
Maintenance Monitor Distance	15000	MILES
Maintenance Monitor Fuel	9090	GALLONS
Maintenance Monitor Time	800	HOURS
Maintenance Monitor Interval Factor	2.00	N/A
Master Password	000000	N/A
Adjustment Password	000000	N/A

HEAVY DUTY DUMP TRUCK CHASSIS OPTION F

EXHAUST SYSTEM Horizontal Aftertreatment System, Frame Mounted Right Side Under Cab, for Single Vertical Tail Pipe, Cab Mounted Right Side

MUFFLER/TAIL PIPE GUARD (1) Bright Stainless Steel

TAIL PIPE (1) Turnback Type, Bright

EXHAUST HEIGHT 10' ✓

TRANSMISSION, MANUAL {Eaton Fuller FRO/FROF-18210C} 10-Speed Manual, Overdrive, Air Shift, Internal Lube Oil Pump

VIRTUAL GAUGE, OIL TEMP, MANL XMSN for Manual Transmission, Requires Premium Cluster

CLUTCH EFFECTS Hydraulic Clutch Actuation System, with Air Assist

Wide track front axle with King Pin centers greater than 71" for improved turn angle and maneuverability

Threaded Spring bushings in lieu of rubber for service inspection

Turn angle greater than 38 degrees in both directions with 425 Tires required for job site maneuverability and service access

Manual reset circuit breakers on all circuits over 5 amps where possible, except headlight and Wiper motor circuits which shall be protected using continuous reset circuit breakers to allow continued operation during a momentary overload for trouble shooting convenience and circuit protection

Electrical Circuit Breaker Panel (No Tools Needed for Access) shall be located inside the cab to prevent exposure to corrosive elements

1 Piece Windshield with a surface area of not less than 1900 sq.in. for improved jobsite visibility

Measurement from center of fuel pedal to back of cab wall 46.5 inches

Outside Aluminum Wheels (6) on Rear and Left Axles

62" Forward Door Opening, Hinges Located at Front Edge of Door. Door Latch System is Removeable as a Module

Windshield Swept Surface Area 900 Sq. In

Wide Track Front Axle with Up To 40 Degree Wheel Cut with 425 Tires (Left and Right)

F: Single canister after treatment

A:

- Light weight, compact design

B:

- 80% less time required to replace
- Significant uptime benefit over EGR, incremental benefit over dual canister SCR

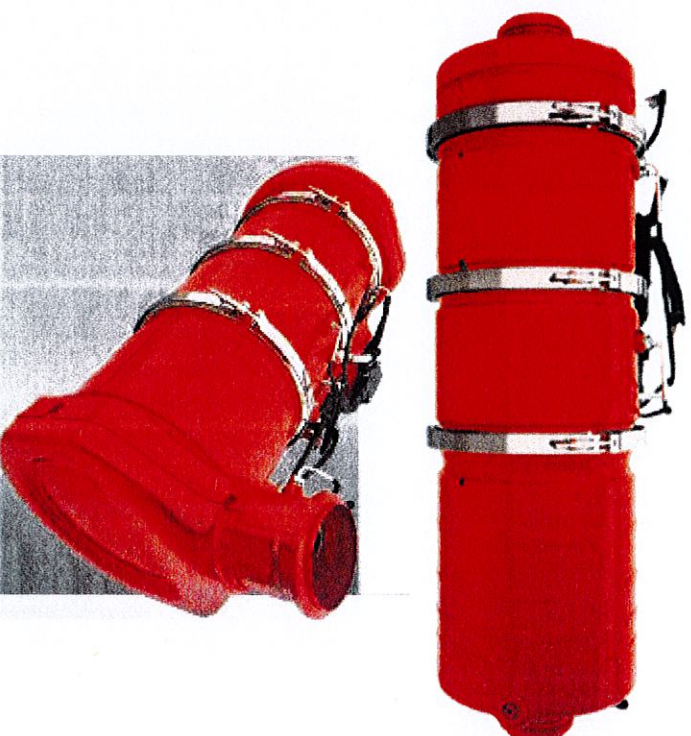

Vertical-vertical is available (07BLX)

Other Features

IT'S UPTIME AT 

Serviceability

- Color-coded and continuously numbered wiring and air lines installed after chassis is painted
- Quality Connect air lines for fewer leaks and less downtime

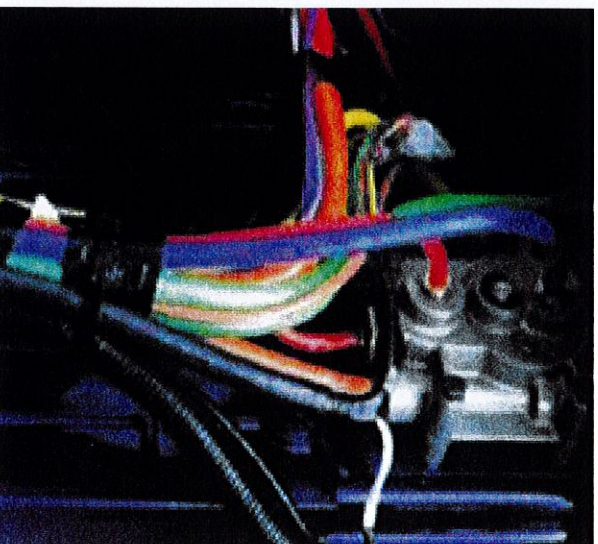

14

08 - HX Electrical Center

F: Fuse / Circuit Breaker panel

A:

- In the top of dash on passenger side
- Gutter

B:

- Easy access to circuit breakers (STD) while providing a flat service for writing
- The gutter protects components against liquids



51

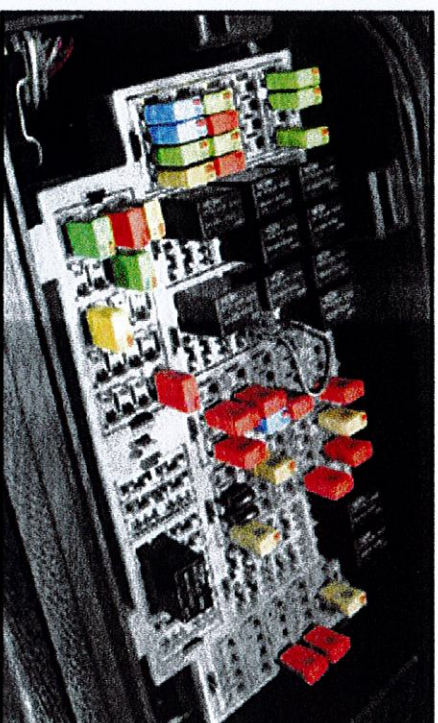

Circuit Breakers

08_0160

13a • TRANSMISSION

MANUAL TRANSMISSION SPECIFICATIONS

Manual Transmissions – 10-Speed (Continued)

Feature Code	13GHP ^[4]	13GHS ^[4]	13GKZ ^[4]		
Manufacturer/ Model Number	Fuller FRO-15210C	Fuller FRO-16210C	Fuller FRO/FROF-18210C		
GCWR (lbs.)	140,000 ^[3]	140,000 ^[3]	140,000 ^[3]		
GVWR (lbs.)	90,000	90,000	90,000		
Ratios & % Split to Next Lower Gear	Ratio	% Split	Ratio	% Split	
	1st	12.69	37	12.94	39
	2nd	9.29	38	9.29	38
	3rd	6.75	38	6.75	38
	4th	4.90	35	4.90	35
	5th	3.62	40	3.62	37
	6th	2.59	37	2.64	39
	7th	1.90	38	1.90	38
	8th	1.38	38	1.38	38
	9th	1.00	35	1.00	35
	10th	0.74		0.74	
Rev. 1	13.75		13.75		
Rev. 2	2.80		2.80		
PTO Opening	Right 6-Bolt; Bottom 8-Bolt ^[2]				
PTO Gear Speed (% of Engine RPM)	84.0 (All)				
Gearing	Twin Countershaft with Conical Clutching Teeth and Helical Gears in Reduction Unit				
Synchronizers	None; But with Synchronized Reduction Unit				
Nominal Torque Capacity (lb-ft)	1550	1650 ^[6]	1850		
Case Material	Grey Iron				
Clutch Housing Material^[2]	Grey Iron ^[5]				
Dry Weight^[1] (lbs.)	668.0	668.0	668.0		
Lubricant Capacity (Pints)	23.5	23.5	23.5		
Comments	Includes Magnetic Discs (3) in Case & Magnetic Drain Plug				

NOTES:

- [1] = Includes Clutch Housing.
- [2] = Thru-Shaft PTO also available.
- [3] = Oil Cooler Mandatory with Engines Rated 400 HP or More.
- [4] = Integral Lube Pump Included.
- [5] = Aluminum Clutch Housing Available (13WAS) (53-lb. Wt. Saving)
- [6] = Peak engine torque up to 1700 lb-ft straight rated is approved..

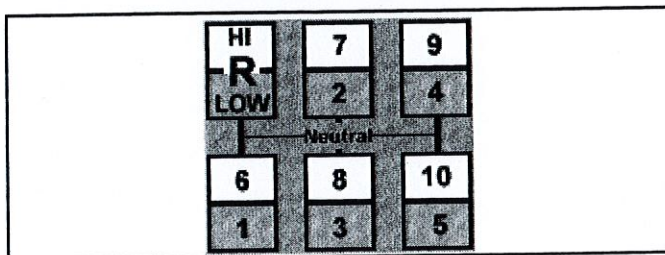

Shift Pattern

13_0024

16

STANDARD CHASSIS SPECIFICATIONS

STANDARD CHASSIS SPECIFICATIONS

HX620 SBA 6x4

Rating		Standard (lbs.)	Maximum (lbs.)
GAW	front	13,200	22,800
	rear	40,000	70,000
GVW	total	53,200	92,800

NOTE: Model Code and Wheelbase Must Be Specified on Order.

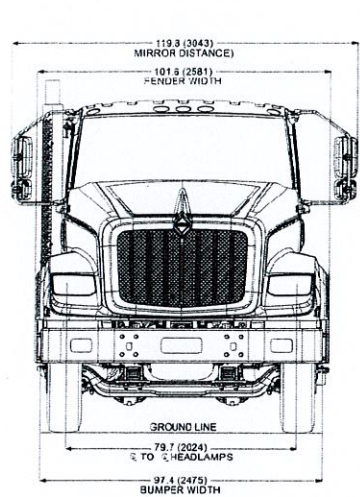

HX620_front

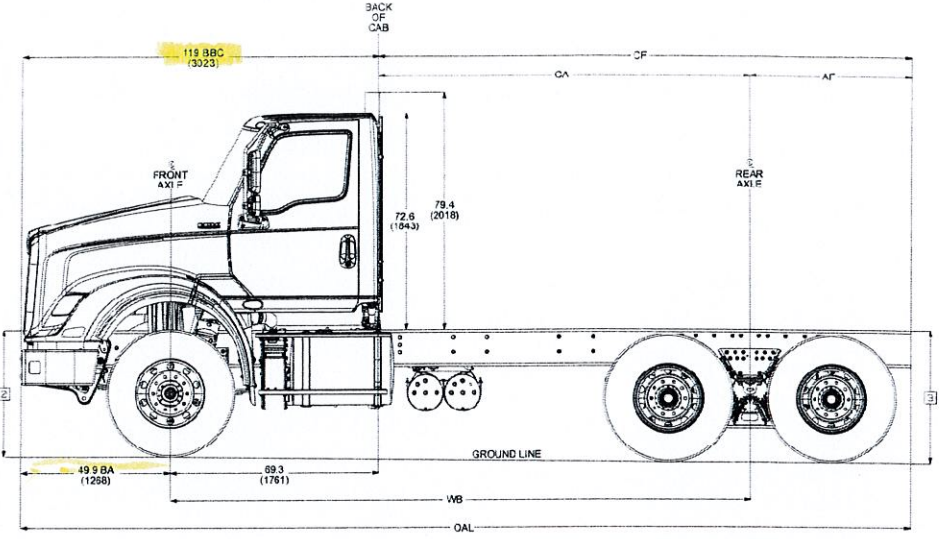

HX620_day_cab_6x4_lsv

Wheelbase (in.)	Chassis Weight (lbs.) **			Dimensions (in.)				Turning Radius	
	Front	Rear	Total	CA	CF	AF	OAL	Curb Clearance	Wall Clearance
175.0	9,444	6,697	16,141	106.0	159.0	53.0	278.0	28 ft. 7 in.	30 ft. 1 in.

- NOTE:** Chart data based on vehicle with standard equipment. Artwork may show some optional equipment.
- * Dimension data and optional add-on weight for this model is based on the 171.0" wheelbase unless otherwise noted.
 - ** Weight includes standard chassis, standard tires, oil and water, but less fuel.
 - [2] Frame Height at centerline of front axle: unloaded – 40.40", loaded – 38.73"
 - [3] Frame Height at centerline of rear axle: unloaded – 42.75", loaded – 40.85"

17

09 – HX Front End



F: Hood

A:

- Raised “crown” appearance
- Increased visibility

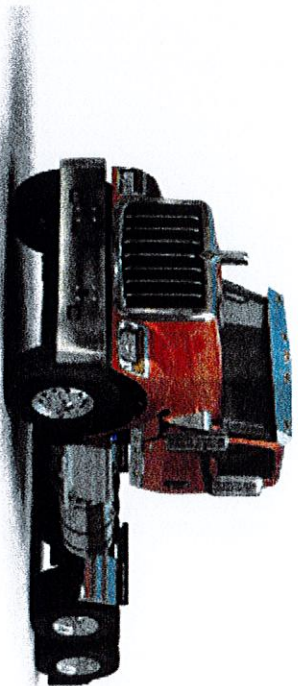

B

- 3-piece design lends itself to easy repair when needed.
- Industry proven DCPD material.

581

16 – HX Extreme Duty Cab

IT'S UPTIME AT 

F: Cab

A:

- Steel construction

B:

- Easier and lower cost to repair than aluminum
- Exceeds both SAE J2422 and European safety standards for roof crush test strength

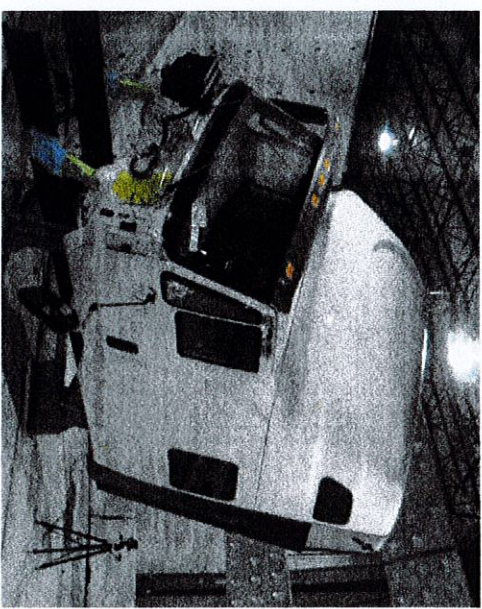

19

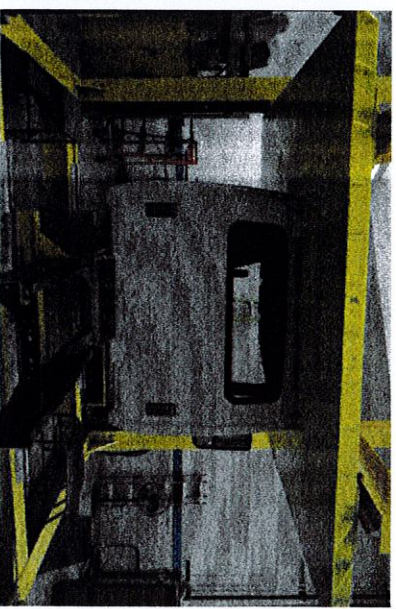

16 – HX Windshield

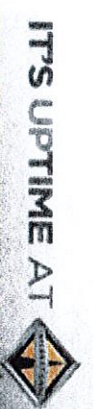

F: Windshield

A:

- Curved windshield
- One piece design
- Bonded in design

B:

- Excellent visibility
- Eliminates blind spot and leak path found on 2 piece Freightliner
- Better sealing than roped in designs

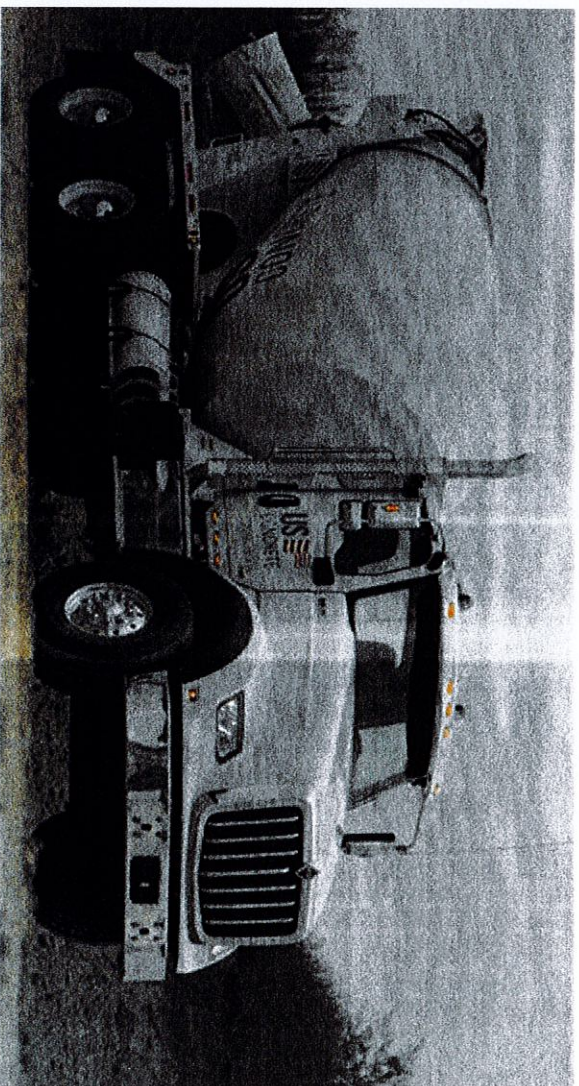

Windshield

- 2,385 In² – 185 In² more than previous HX models
- 16VSL – Heated

20

CAB INTERIOR | cab size and dimensions | key numbers

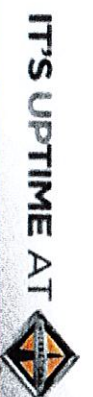

CAB INTERIOR cab size and dimensions



Series	HX Series	HX Series 2021	Peterbilt 567	Kenworth T880
Width				
A-pillar to A-pillar at Dash	68.5"	69.25"	66"	66.5"
A-pillar to A-pillar at Roof	67.5"	66"	66.75"	66.75"
B-pillar to B-pillar at Dash	66.75"	72"	70.5"	68.5"
B-pillar to B-pillar at Roof	67"	68.5"	70.5"	70.25"
Width at Shoulder Level	74.25"	78"	78.25"	78.5"
Width at Hip Level	68.25"	72.5"	70.75"	67.25"
Centerline of Seat to Door	15.5"	14"	15.5"	14.25"
Depth				
A-pillar to BOC at Dash	42.5"	44.5"	47"	47.25"
A-pillar to BOC at Roof	36.5"	36.5"	39"	40.5"
Fuel Pedal Center to Rear Wall	44"	46.75"	43.25"	43"
Height				
Floor to Roof at Seat Edge	56"	56.5"	58.5"	58.5"
Floor to Roof at Dash Edge	52.5"	52"	54.5"	54.5"
Floor to Roof at B-pillar	57"	56.75"	59.5"	60.5"
Total Volume (cu. ft.) [*]	88.32	94	98.16	99.2"

*Volume is calculated from the above as well as additional data not included in this table.

Key Advantages — The HX Series 2021 cab is wider at the dash than the 567 and over three inches wider than the T880. It is also wider at the hips than the Peterbilt 567 and over five inches wider than the T880. Cab depth also shows the HX Series 2021 is more than three inches deeper from the fuel pedal to rear wall (the back of cab) than both the 567 and T880.

Orange text denotes the best dimension for the respective attribute.

12

16 – HX Rear Window



HX = 648 sq in
HV = 800 sq in
6" wider and 23% larger overall

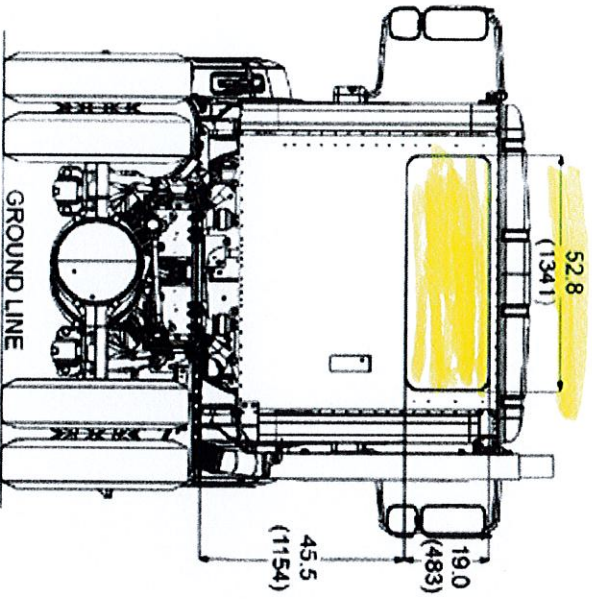

Current HX

Rear Window Glass

- 16XDD – Polycarbonate Shatter Resistant

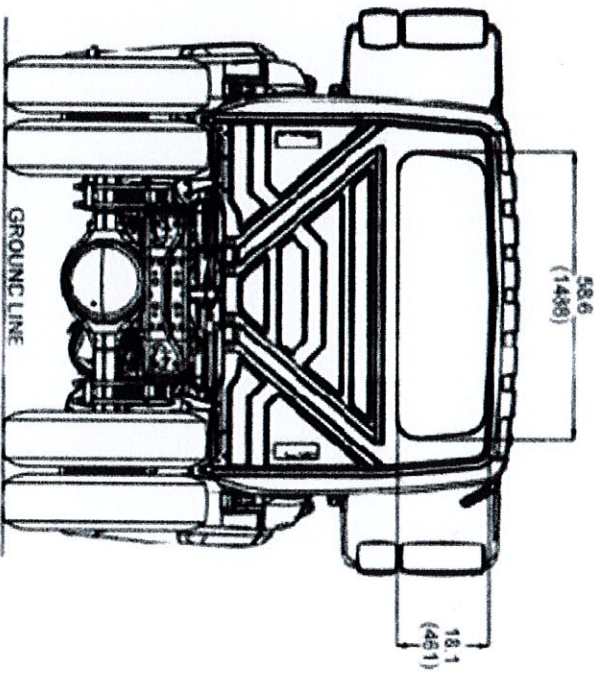

2022 HX

AXLE CONFIGURATION

An axle configuration feature is required on all HX models.

■ ■ Standard

01AND

AXLE CONFIGURATION {Navistar} 6x4

■ ■ Optional

01ANF

AXLE CONFIGURATION {Navistar} 8x6 Tridem

FRAMES

■ FRAME RAILS

Crossmembers and components attached to the frame are bolted to the web of the frame rails to produce a clean, straight rail top with no bolt heads or rivets to interfere with equipment mounting.

Huck-Spin fasteners are used for chassis assembly in lieu of conventional threaded fasteners. Huck-Spin fasteners will meet the ultimate tensile strength values and clamp load levels achievable with our type-8 flange threaded fasteners. The Huck-Spin fasteners also have flanged faces.

The Huck-Spin fastener is directly tensioned, rather than indirectly, through application of torque. The direct tensioning of the Huck-Spin fastener results in more consistent tightness of joints due to more consistent clamp loads.

During installation, the Huck-Spin collars are swagged on to the pin grooves. This type of installation results in high resistance to collar rotation and vibrational loosening.

Type-8 flangehead threaded fasteners will be used interchangeably with Huck-Spin fasteners in service. Type-8 flange threaded fasteners will continue to be used for manufacturing assembly where it is not feasible to use Huck-Spin fasteners due to accessibility or other plant considerations.

■ ■ Standard

01CGC

FRAME RAILS Heat Treated Alloy Steel (120,000 PSI Yield); 12.250" x 3.380" x 0.375" (304.8mm x 85.6mm x 9.5mm); 550.0" (13970mm) Maximum OAL

■ ■ Optional

01CGD

FRAME RAILS Heat Treated Alloy Steel (120,000 PSI Yield); 12.50" x 3.750" x 0.500" (317.5mm x 95.25mm x 12.7mm); 480.8" (12212mm) Maximum OAL

01CAG

FRAME RAILS Heat Treated Alloy Steel (120,000 PSI Yield); 10.250" x 3.610" x 0.375" (260.4mm x 91.7mm x 9.5mm); 456.0" (11582mm) Maximum OAL

01CBU

FRAME RAILS Heat Treated Alloy Steel (120,000 PSI Yield); 10.125" x 3.580" x 0.312" (257.2mm x 90.9mm x 8.0mm); 480.0" (12192) Maximum OAL

■ FRAME RAILS WITH TAPERED REAR

■ ■ Optional

01616

FRAME RAILS WITH TAPERED REAR



Tapered Rear Frame

01_0336

FRAMES • 01

FRAME RAIL CROSS-SECTION SPECIFICATIONS

NOTE: Dark area represents frame reinforcement.

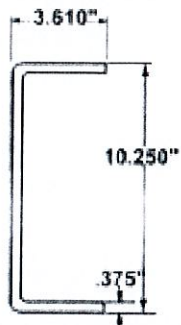

01CAG

01_0081

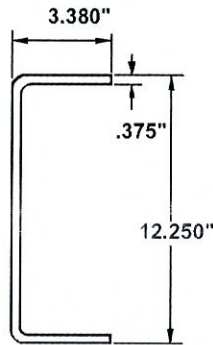

01CGC

01_0283

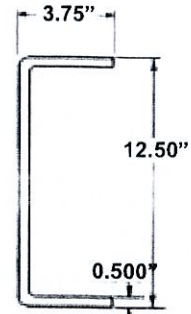

01CGD

01_0284

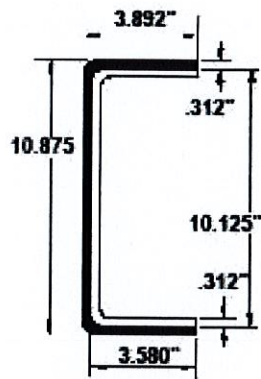

01CBU/01GBP

01_0338

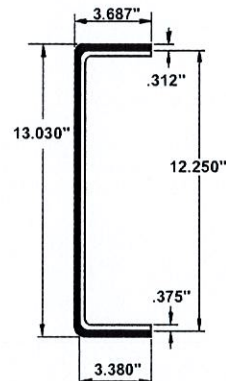

01CGC/01GDS

01_0285

Side Rail Descriptions & Reinforcement Descriptions [2]									
Frame Key Code	Dimensions (Inches)			Weight Per Rail/Per Pair (Lbs.-In.)	Yield Strength Nominal (psi)	Material #	Section Modulus ^[1] (Inches ³)		Resisting Bending Moment (In.-Lbs.)
	Depth	Width	Thickness				Nominal	Design	
Straight Channel Side Rail									
01CAG	10.250	3.610	0.375	1.71/3.42	120,000	C	17.03	2,037,600	
01CGC	12.250	3.380	0.375	1.87/3.74	120,000	C	21.01	2,521,200	
01CGD	12.500	3.750	0.500	2.58/5.16	120,000	C	29.47	3,536,400	
Straight Channel Side Rail with Outer Full Channel Reinforcement									
01CBU	10.125	3.580	0.312	2.95/5.90	120,000	C	29.84	3,580,800	
01GBP	10.813	3.893	0.312		120,000	C			
01CGC	12.250	3.380	0.375	3.56/7.12	120,000	C	40.45	4,854,000	
01GDS	13.030	3.687	0.312		120,000	C			

NOTES:

C = Heat Treated Alloy Steel

[1] = Section Modulus: Nominal calculated using design dimensions – indicates the design load capacity of the frame.

[2] = Reinforcement dimensions and specifications are shown in italics.

24

NORTH AMERICAN HEAVY-DUTY TRUCK COVERAGES.

Cummins Heavy-Duty Base Engine Warranty coverage for the X15 Efficiency Series, X15 Performance Series and ISX12/X12 is better and more comprehensive than ever.

From the block casting to the injectors, virtually everything is covered for two years/250,000 miles (402,336 km), whichever comes first. That includes the aftertreatment system.

Plus, we continue to offer a variety of comprehensive extended coverage plans on all Cummins Heavy-Duty engines, for added security. These protection plans provide financial peace of mind, insuring you against unforeseen expenses for years to come. And they can be included in the financing of your new truck for just dollars a day.

Cummins Extended Coverage plans are honored at all authorized Cummins service locations and backed by Cummins Care. No matter where your business takes you, you've always got a Cummins-authorized service facility nearby, with over 3,700 locations in North America. You can be assured that every contingency is covered.

X15, ISX12/X12 Base Warranty.

There's no greater assurance of quality. A product's warranty is ironclad proof that you can take to the bank, especially when it's a 2-year/250,000-mile (402,336 km) warranty on a Cummins Heavy-Duty X15 or ISX12/X12 engine. Virtually everything is included in this standard warranty with no deductible:

- 100 percent parts and labor on warrantable failures*
- Travel or towing when an engine is disabled by a warrantable failure
- Includes aftertreatment

*Warrantable failures are those due to defects in Cummins material or factory workmanship. Refer to legal bulletins for specific details.

X15 and ISX12/X12 Extended Coverage Plans.

PROTECTION PLAN 1

You can plan your maintenance and repair budgets with confidence when you've got extended coverage for your Heavy-Duty engines. Protection Plan 1 is our most comprehensive package, including the turbocharger, water pump, fuel injectors, air compressor and fuel pump for a variety of year and mileage options ranging from three to five years and 100,000 to 500,000 miles (160,934-804,672 km) for the X15 Performance Series and ISX12/X12, and from three to six years and 100,000 to 600,000 miles (160,934-965,606 km) for the X15 Efficiency Series. Mileage range may vary by engine and length of coverage. Contact your local distributor or dealer for duration details to choose the plan that best meets your equipment trade cycle and financial goals.

Items covered under Protection Plan 1 include:

- Internal components and major engine systems, including the turbocharger, water pump, fuel injectors*, flywheel, wiring harnesses, front gear housing and thermostat
- Registered parts and labor on covered failures
- Travel or towing when an engine is disabled by a warrantable failure is covered when you purchase Plan 1 coverage with the travel option

*Does not include hydrocarbon doser injector.

LIMITED WARRANTY FOR HX[®] MODELS

*Effective with vehicles built January 1, 2021 or later

BASIC VEHICLE

Navistar, Inc., at its option, will repair or replace any part of this vehicle that proves defective in material or workmanship, in normal use and service, with new or ReNEMed[®] parts, based on the Component Coverages below. Exceptions are listed below:

BASIC VEHICLE COVERAGE (all coverage are whichever occurs first)	Months	Miles/Km (000)
Basic Vehicle Warranty (See exceptions listed below)	12	Unlimited
Towing (Vehicles with N13 engine failures only)	24	Unlimited
Towing (Vehicles with A26 engine failures only)	24	Unlimited
Towing (First 90 days see below) (Vehicle Down Situations Only)	3	Unlimited

Note: Items not listed in warranty exceptions follow basic warranty.

WARRANTY EXCEPTIONS

CHASSIS COVERAGE	Months	Miles/Km (000)
Frame side rails	60	Unlimited
Aluminum Cab		
Cab/cowl structure	60	Unlimited
Cab/cowl perforation corrosion	60	Unlimited
Steel Cab		
Cab/cowl structure	120	Unlimited
Cab/cowl perforation corrosion	120	Unlimited
ENGINE COVERAGE	Months	Miles/Km (000)
International A26 Engine	24	Unlimited
International A26 Major Components	60	500/800
<i>Major Components are cylinder block, main bearing bolts, cylinder head castings and capscrews, crankshaft, camshaft, cam follower, connecting rods/caps/bolts, intake manifold castings, and gear train gears.</i>		
Rescue Application Only (Fire Truck, Ambulance, Emergency)		
International A26 Engine	60	100/160
DRIVE TRAIN COVERAGE	Months	Miles/Km (000)
Rear Axle Weight Ratings Greater than 52,000 lb		
Front Axle Assembly	12	Unlimited
Rear Axle and Differential	12	Unlimited
Transmission	12	Unlimited
Rear Axle Weight Ratings of 52,000 lb and less		
Front Axle Assembly	36	300/480
Rear Axle and Differential	36	300/480
Transmission	36	300/480
MISCELLANEOUS COVERAGE	Months	Miles/Km (000)
Brightwork, Chassis Paint and Corrosion (other than Cab)	6	Unlimited
Hood/Cab Paint	12	Unlimited

FIRST 90 DAYS FROM DELIVERY TO USER (DTU)

Correction of loose fasteners, squeaks, rattles and unusual noises; Towing (unless specific coverage is stated above); Adjustments and Maintenance (such as air headlights, adjust brakes/clutch, adjust steering system, check and fill coolant levels)

Navistar Diesel Engine Coverage Includes:

Engine block, cylinder heads, internally lubricated components, fuel pump, high pressure pump, turbocharger, water pump, air compressor, injectors/nozzles, electronic engine modules, engine relays, engine sensors and regulators required for electronic engine operation, and certain aftertreatment components. Excluding: attaching accessories (e.g., fan clutch, alternator, starter, etc.), and externally mounted electrical and filtration systems.

WHAT IS NOT INCLUDED UNDER BASIC COVERAGE

Components/Items

- Components warranted by their respective manufacturers (such as non-International[®] brand engines, tires, Allison Transmissions, lubricants)
- Bodies, equipment, and accessories installed by other than authorized International[®] Truck employees at International[®] Truck manufacturing plants
- Front and rear axle alignment
- Front & Rear axle coverage excludes brakes, wheel ends, axle shafts, controls & attachments

Repairs & Maintenance

- Maintenance-related items/repairs, or those needed as a result of normal wear and tear, including tune-ups, brake/clutch linings, windshield wiper blades, tire balancing, lubrication, and other similar procedures/parts required to keep vehicle in good working condition
- Failures that are the result of poor fuel quality, water in fuel, rust, etc.
- Repairs needed as a result of vehicle misuse, negligent care, improper maintenance, improper operation, or the result of accident or collision
- Fade, runs, mismatch or damage to paint, trim items, upholstery, chrome, polished surfaces, etc., resulting from environmental causes such as improper polishes, cleaners or washing solutions, or chemical and industrial fallout
- Failure to observe published capacity or load specifications for engine, transmission, propeller shaft, axles (powertrain) and suspension

Other

- Vehicles sold and/or operated outside the United States and Canada
- Vehicles/components that have had unauthorized alterations or modifications
- Vehicles on which the odometer reading has been altered
- Loss of time or use of the vehicle, loss of profits, inconvenience, or other consequential or incidental damages or expenses
- Replacement of defective parts with parts other than those provided by Navistar, Inc

26

STANDARD CHASSIS SPECIFICATIONS

STANDARD CHASSIS SPECIFICATIONS

HX620 SBA 6x4

Rating		Standard (lbs.)	Maximum (lbs.)
GAW	front	13,200	22,800
	rear	40,000	70,000
GVW	total	53,200	92,800

NOTE: Model Code and Wheelbase Must Be Specified on Order.

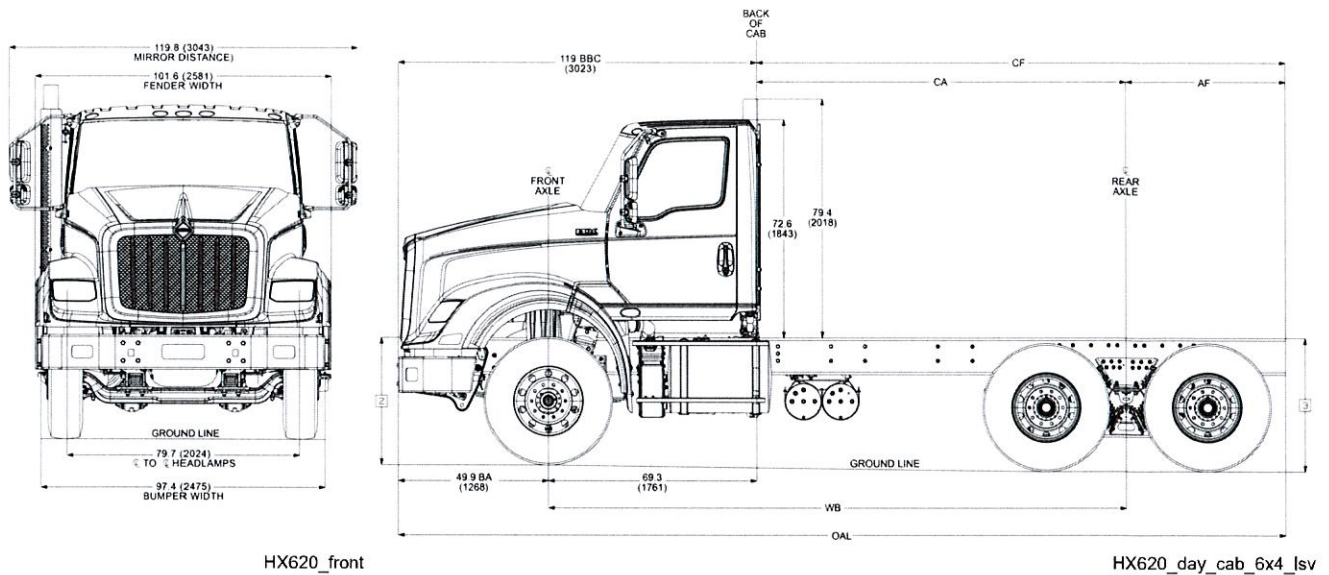

Wheelbase (in.)	Chassis Weight (lbs.)**			Dimensions (in.)				Turning Radius	
	Front	Rear	Total	CA	CF	AF	OAL	Curb Clearance	Wall Clearance
175.0	9,444	6,697	16,141	106.0	159.0	53.0	278.0	28 ft. 7 in.	30 ft. 1 in.

NOTE: Chart data based on vehicle with standard equipment. Artwork may show some optional equipment.

* Dimension data and optional add-on weight for this model is based on the 171.0" wheelbase unless otherwise noted.

** Weight includes standard chassis, standard tires, oil and water, but less fuel.

[2] Frame Height at centerline of front axle: unloaded – 40.40", loaded – 38.73"

[3] Frame Height at centerline of rear axle: unloaded – 42.75", loaded – 40.85"



INTERNATIONAL®

HX

SERIES HEAVY DUTY

HX620 SBA

STANDARD EQUIPMENT

MODEL CODE: HX62000

01 FRAMES

- 01AND - AXLE CONFIGURATION {Navistar} 6x4
NOTE: Pricing may change if axle configuration is changed.
- For U.S. Only
- 01CGC - FRAME RAILS Heat Treated Alloy Steel (120,000 PSI Yield); 12.250" x 3.380" x 0.375" (304.8mm x 85.6mm x 9.5mm); 550.0" (13970mm) Maximum OAL

- 01LRB - BUMPER, FRONT Contoured, Steel, Painted, Heavy Duty, for HX
- 01WXX - WHEELBASE RANGE 148" (375cm) Through and Including 189" (480cm)

02 AXLE, FRONT

- 02ASG - AXLE, FRONT NON-DRIVING {Meritor MFS-13-143A} Wide Track, I-Beam Type, 13,200-lb Capacity

03A SUSPENSION, FRONT

- 03ACH - SUSPENSION, FRONT, SPRING Multileaf, Shackle Type, 14,000-lb Capacity, with Shock Absorbers

04 BRAKES

- 04091 - BRAKE SYSTEM, AIR Dual System for Straight Truck Applications
* BRAKE LINES Color and Size Coded Nylon
* PARKING BRAKE CONTROL Yellow Knob, Located on Instrument Panel
* PARKING BRAKE VALVE For Truck
* QUICK RELEASE VALVE On Rear Axle for Spring Brake Release: 1 for 4x2, 2 for 6x4
* SPRING BRAKE MODULATOR VALVE {Bendix} SR-7 with relay valve for 6x4/8x6
- 04AZJ - AIR BRAKE ABS {Bendix AntiLock Brake System} 4-Channel (4 Sensor/4 Modulator) Full Vehicle Wheel Control System, with Automatic Traction Control
- 04XCJ - BRAKES, FRONT {Bendix Spicer ADB22X} Air Disc Type, Extended Service, Size 22.5", 23,000-lb Capacity
- 04XDW - BRAKE CHAMBERS, FRONT AXLE 18 Sqn, for Air Disc Brakes
- 04XCX - BRAKES, REAR {Bendix Spicer ADB22X} Air Disc Type, Extended Service, Size 22.5", 26,000-lb Capacity per Axle

04 BRAKES

- 04XEA - BRAKE CHAMBERS, REAR AXLE 18/24 Sqn Spring Brake, Double Diaphragm, for Air Disc Brakes
- 04SPM - AIR COMPRESSOR {Bendix BA-921 Head Unload} 15.9 CFM
- 04EDM - AIR DRYER {Bendix AD-HF} with Heater, Includes Pressure Protection Circuits, Safety Valve, Integral Purge Tank, Governor Pressure Settings 110 psi Cut-In/130 psi Cut-Out, Integrated PuraGuard Coalescing Filtration
- 04VKC - AIR DRYER LOCATION Mounted Inside Left Rail, Back of Cab
- 04VKK - AIR TANK LOCATION (2) Mounted Under Battery Box, Outside Right Rail, Back of Cab, Perpendicular to Rail
- 04WXR - DRAIN VALVE (2) {Berg} with Pull Chains, for Air Tanks

05 STEERING

- 05PSA - STEERING GEAR {Sheppard M100} Power
- 05710 - STEERING COLUMN Tilting and Telescoping
- 05CAW - STEERING WHEEL 4-Spoke; 18" Dia., Black

06 DRIVELINES

- * END YOKES Half-Round, Easy Service (All)
- 06DHB - DRIVELINE SYSTEM {Dana Spicer} 1810HD Main Driveline with 1710 Interaxle Shaft, for 6x4

07 EXHAUST SYSTEM

- 07BLY - EXHAUST SYSTEM Horizontal Aftertreatment System, Frame Mounted Right Side Under Cab, for Single Vertical Tail Pipe, Cab Mounted Right Side
- 07SDK - ENGINE COMPRESSION BRAKE by Jacobs; for N13/A26 Engines, with Selector Switch and On/Off Switch
- 07WDM - EXHAUST HEIGHT 10'
- 07WDT - TAIL PIPE (1) Straight Type

08 ELECTRICAL

- 08000 - ELECTRICAL SYSTEM 12-Volt, Standard Equipment
* HAZARD SWITCH Push On/Push Off, Located on Instrument Panel to Right of Steering Wheel
* HEADLIGHT DIMMER SWITCH Integral with Turn Signal Lever
* PARKING LIGHT Integral with Front Turn Signal and Rear Tail Light

08 ELECTRICAL

- (CONT.) * STARTER SWITCH Electric, Key Operated
- * STOP, TURN, TAIL & B/U LIGHTS Dual, Rear, Combination with Reflector
- * WINDSHIELD WIPER SWITCH 2-Speed with Wash and Intermittent Feature (5 Pre-Set Delays), Integral with Turn Signal Lever
- * WINDSHIELD WIPERS Single Motor, Electric, Cowl Mounted
- 08GXJ - ALTERNATOR {Leece-Neville AVI160P2013} Brush Type, 12 Volt, 160 Amp Capacity, Pad Mount
- 08VUK - BATTERY BOX Aluminum, with Plastic Cover, 18" Wide, 2-4 Battery Capacity, Mounted Right Side Back of Cab
- 08MSG - BATTERY SYSTEM {Fleetrite} Maintenance-Free, (3) 12-Volt 1980CCA Total, Top Threaded Stud
- 08RJW - CB RADIO Omit Power Feeds, Power Source and Wiring
- 08XAH - CIRCUIT BREAKERS Manual-Reset (Main Panel) SAE Type III with Trip Indicators, Replaces All Fuses
- 08WXB - HEADLIGHT WARNING BUZZER Sounds When Head Light Switch is on and Ignition Switch is in "Off" Position
- 08XNY - HEADLIGHTS Halogen
NOTE: STANDARD IN USA
- 08653 - HORN, AIR Single, Located Under Cab
- 08VAY - HORN, ELECTRIC Disc Style
- 08RMX - RADIO Omit, Includes Wiring and Antenna
- 08RMV - SPEAKERS (2) 6.5" Dual Cone Mounted in Doors
- 08WXG - STARTING MOTOR {Mitsubishi Electric Automotive America 105P} 12-Volt, with Soft-Start
- 08WEZ - TURN SIGNAL SWITCH Self-Canceling
- 09 FRONT END
- 09ASE - FRONT END Tilting, Composite
- 09HCL - GRILLE Black Vertical Accent Bars, with Black Mesh
- 09AAB - LOGOS EXTERIOR Model Badges
- 09AAE - LOGOS EXTERIOR, ENGINE Badges

Refer To General Info for Metric Conversion Tables



INTERNATIONAL®

HX

SERIES HEAVY DUTY

HX620 SBA

STANDARD EQUIPMENT

MODEL CODE: HX62000

10 PAINT & MISCELLANEOUS

- 10AGB - COMMUNICATIONS MODULE Telematics Device with Over the Air Programming; Includes Five Year Data Plan and International 360
- 10060 - PAINT SCHEMATIC, PT-1 Single Color, Design 100
- 10761 - PAINT TYPE Base Coat/Clear Coat, 1-2 Tone

11 CLUTCH

- 11MGP - CLUTCH {Eaton Fuller ECA 1850} Self-Adjusting, 15.5" Dia Two-Plate, Cast Angle Spring, Ceramic, 7-Spring Damper with Pre-Damper, 2"-10 Tooth Spline, 1850 lb-ft Torque Capacity

12 ENGINE

- 12BET - ENGINE, DIESEL {International A26} EPA 2021, 370HP @ 1700 RPM, 1350 lb-ft Torque @ 900 RPM, 2100 RPM Governed Speed, 370 Peak HP (Max)

- 12XBC - RADIATOR Aluminum, Welded, Down Flow, Front to Back System, 1325 SqIn, with 806 SqIn Charge Air Cooler
 - * RADIATOR HOSES Premium, Rubber

- 12THT - FAN DRIVE {Horton Drivemaster} Two-Speed Type, Direct Drive, with Residual Torque Device for Disengaged Fan Speed
 - * FAN Nylon

- 12VCA - AIR CLEANER Single Element, with Integral Pre-Cleaner, Engine Mounted

- 12703 - ANTI-FREEZE Red, Extended Life Coolant; To -40 Degrees F/ -40 Degrees C, Freeze Protection

- 12WTA - FAN DRIVE SPECIAL EFFECTS Fan Cooling Ring with Fan Shroud Effects, Engine Mounted

- 12WCX - HOSE CLAMPS, RADIATOR HOSES {Gates} Shrink Band Type

- 12WYZ - RADIATOR DRAIN & FILL FITTING SPECIAL; To Vacuum Out or Fill the Cooling System from the Bottom of Radiator, for Use with Quick-Connect Radiator Drain Tool or Shop Coolant Evacuation-Fill System

13 TRANSMISSION

- 13GWZ - TRANSMISSION, MANUAL {Eaton Fuller UltraShift+ FO-16E313A-MHP} 13-Speed Fully Automated Manual, Aluminum Clutch Housing, Overdrive, Electronic Shift Controls and Clutch Actuation, Air Range Shift, Internal Lube Oil Pump, Hill Start Aid

14A AXLE, REAR

- 14GVU - AXLE, REAR, TANDEM {Meritor MT-40-14X-4DFR-P} Single Reduction, 40,000-lb Capacity, with Lube Oil Pump, .433"(11mm) Wall Housing Thickness, R Wheel Ends
 - * RATIO: 2.64, 3.08, 3.25, 3.36, 3.42, 3.55, 3.70, 3.90, 4.11, 4.33, 4.63, 4.88, 5.29, 5.86, 6.14, 6.43, 6.83 OR 7.17

14B SUSPENSION, REAR

- 14UMV - SUSPENSION, REAR, TANDEM {Hendrickson HMX EX 400} Walking Beam, 40,000-lb Capacity, 54" Axle Spacing, Rubber Springs, with Transverse Torque Rods, Rubber End Bushings

15 FUEL TANKS

- 15SSN - FUEL TANK Non-Polished Aluminum, 24" Dia, 60 US Gal (227L), Mounted Left Side, Under Cab
- 15WDR - DEF TANK 10.6 US Gal (40L) Capacity, Frame Mounted Outside Left Rail, Under Cab
- 15LKU - FUEL/WATER SEPARATOR {Racor} Fuel Pre-Filter and Filter Base, Includes Water-In-Fuel Sensor

16 CAB

- 16030 - CAB Conventional, Day Cab
 - * CAB REAR SUSPENSION Air
 - * CLEARANCE/MARKER LIGHTS (5) LED Roof Mounted
 - * COAT HOOK, CAB Located on Rear Wall, Centered Above Rear Window
 - * CONSOLE, CENTER Includes Two Cup Holders and One Additional Storage Area
 - * CONSOLE, OVERHEAD Molded Plastic with Dual Storage Pockets, Retainer Nets and CB Radio Pocket; Located Above Driver and Passenger
 - * COURTESY LIGHT (2) Driver and Passenger Door Mounted

16 CAB

(CONT.)

- * DOME LIGHT, CAB Rectangular, Door and Instrument Panel Mounted Switch Activated, Timed Theater Dimming, Center Mounted, Integral to Console
- * FLOOR COVERING Rubber, Black
- * GLASS, ALL WINDOWS Tinted
- * GRAB HANDLE, CAB INTERIOR (1) "A" Pillar Mounted, Passenger Side
- * GRAB HANDLE, CAB INTERIOR (4) "B" Pillar and Door Mounted, Two Each Side
- * READING LIGHT, CAB Located in Overhead Console
- * STORAGE POCKET, DOOR (2) Full Length, Driver and Passenger Door
- 16XTM - ACCESS, CAB Aluminum, Driver & Passenger Sides, Two Steps per Door, for use with Day Cab or Sleeper Cab
- 16BAM - AIR CONDITIONER with Integral Heater and Defroster
 - * HOSE CLAMPS, HEATER HOSE {Mubea} Constant Tension Clamps
- 16VKK - CAB INTERIOR TRIM Diamond, for Day Cab
- 16GEG - GAUGE CLUSTER Premium Level; English with English Electronic Speedometer
 - * GAUGE CLUSTER DISPLAY: Base Level (3" Monochromatic Display), Premium Level (5" LCD Color Display); Odometer, Voltmeter, Diagnostic Messages, Gear Indicator, Trip Odometer, Total Engine Hours, Trip Hours, MPG, Distance to Empty/Refill for Fuel/DEF, DPF Level
 - * GAUGE CLUSTER Speedometer, Tachometer, Engine Coolant Temp, Fuel Gauge, DEF Gauge, Oil Pressure Gauge, Primary and Secondary Air Pressure
 - * WARNING SYSTEM Low Fuel, Low DEF, Low Oil Pressure, High Engine Coolant Temp, Low Battery Voltage (Visual and Audible), Low Air Pressure (Primary and Secondary)
- 16XJP - INSTRUMENT PANEL Wing Panel
- 16HKT - IP CLUSTER DISPLAY On Board Diagnostics Display of Fault Codes in Gauge Cluster

Refer To General Info for Metric Conversion Tables



INTERNATIONAL®

HX

SERIES HEAVY DUTY

HX620 SBA

STANDARD EQUIPMENT

MODEL CODE: HX62000

16 CAB (CONT.)

16SNL - MIRRORS (2) C-Loop,
Black Heads and Arms, 7.5" x
14" Flat Glass, Includes
7.5" x 7" Convex Mirrors,
for 102" Load Width

NOTE: Mirror Dimensions are
Rounded to the Nearest
0.5"

16XRX - MODESTY PANEL Painted

16LWK - SEAT, DRIVER (ISRI)
Series 300, Air Suspension,
High Back, Vinyl, Single
Chamber Lumbar, Inboard
Armrest, Suspension Cover,
Fore/Aft Isolator, Cushion
Extension, Seat Tilt

16400 - SEAT, PASSENGER Omit
Item

16WJU - WINDOW, POWER (2) and
Power Door Locks, Left and
Right Doors, Includes
Express Down Feature

27/28 WHEELS & TIRES

27DUW - WHEELS, FRONT {Accuride
51408} DISC; 22.5x8.25 Rims,
Powder Coat Steel, 2-Hand
Hole, 10-Stud, 285.75mm BC,
Hub-Piloted, Flanged Nut,
with Steel Hubs

28DUW - WHEELS, REAR {Accuride
51408} DUAL DISC; 22.5x8.25
Rims, Powder Coat Steel,
2-Hand Hole, 10-Stud,
285.75mm BC, Hub-Piloted,
Flanged Nut, with Steel Hubs

737213 5415 (02) 11R22.5 14-PR
LR-G SINGLE FRONT RADIAL
TIRES {Continental Tire
HSR2}

737213 5415 (08) 11R22.5 14-PR
LR-G DUAL REAR RADIAL TIRES
{Continental Tire HSR2}

40 WARRANTY

40132 - WARRANTY Standard for
HX520, HX620, Effective with
Vehicles Built January 1,
2021 or Later, CTS-2015B

Refer To General Info for Metric Conversion Tables

INTERNATIONAL® HX SERIES SECTION 585 - STANDARD EQUIPMENT

04/15/2022

PLH-284 REVISION NO. 322 PAGE 585-4

SUBJECT TO CHANGE WITHOUT NOTICE

Printed in the United States of America

All Taxes Extra, when Applicable

STATE OF ALABAMA

MONTGOMERY COUNTY

CONTROL NO.
0322001960

LICENSE NO.
0003000

ACCOUNT NO.
001960

ISSUED TO:

SOUTHLAND INTERNATIONAL TRUCKS INC
200 OXMOOR BLVD
HOMEWOOD, AL 35209

LICENSE YEAR
2021-2022

DATE ISSUED		
11	01	2021
MO.	DAY	YR.

LICENSE TYPE	
STORE LICENSE	<input type="checkbox"/>
CHAIN STORE LICENSE	<input type="checkbox"/>
OCCUPATIONAL LICENSE	<input checked="" type="checkbox"/>

BUSINESS LOCATION:
1563 MAXWELL BLVD
MONTGOMERY, AL 36104

EXPIRES
September 30, 2022
RENEW IN OCTOBER

SECTION	BUSINESS TYPE	LICENSE AMOUNT	FEE	PENALTY	CITATION	INTEREST	TOTAL
051	AUTO DEALER Add. Info - REGULATORY NUMBER: 010015200	210.00	1.00	0.00	0.00	0.00	211.00

<p>TRANSFER OF LICENSE Evidence having been adduced before me that a bona fide sale of the business licensed by this certificate has been made by licensee, this license is transferred to said purchaser.</p>						TOTAL	211.00
<p>Name of Purchaser</p>						MAIL FEE	0.00
<p>Issuing Authority</p>						TOTAL WITH MAIL FEE	211.00

KATHLEEN D. BAXTER
State Comptroller

VERNON BARNETT
Commissioner of Revenue

JC LOVE, III
Issuing Authority

L4 11/01/2021 01:22PM CHECK

11/01/2021 01:22PM
SOUTHLAND INTERNATIONAL TRUCKS INC
1563 MAXWELL BLVD
MONTGOMERY AL36104
051 - AUTO DEALER 211.00
Total: 211.00

Acct Number 001960

License#: 0003000

THIS
LICENSE
EXPIRES

December 31st

PLEASE RENEW
BY FEBRUARY 1ST
OF THE FOLLOWING YEAR

CITY OF MONTGOMERY
MONTGOMERY, ALABAMA

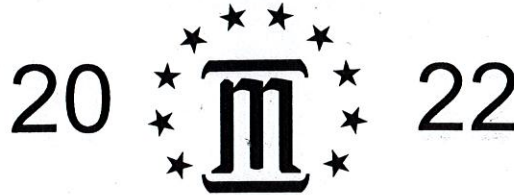

BUSINESS LICENSE

No. 202200006687

LICENSE VALID
ONLY AT LOCATION
INDICATED
NON TRANSFERABLE

MAILING NAME AND ADDRESS

LOCAL TRADE NAME AND PHYSICAL LOCATION

SOUTHLAND INTL TRUCKS INC
200 OXMOOR BLVD
HOMEWOOD, AL 35209

SOUTHLAND INTL TRUCKS INC
1563 MAXWELL BLVD
MONTGOMERY, AL 36104

THE FIRM, CORPORATION, ORGANIZATION, BUSINESS OR PERSON, WHOSE NAME APPEARS ABOVE HAS PAID THE REQUIRED LICENSE FEE AND IS AUTHORIZED TO ENGAGE IN BUSINESS IN MONTGOMERY, ALABAMA AS INDICATED BELOW.

CODE	ACCOUNT NUMBER	LICENSE NUMBER	RECEIPT NUMBER	TYPE OF LICENSE
441100	5010100-BUS TRUCK SALES	202200006687		

DATE ISSUED

02/16/2022

MONTGOMERY,
ALABAMA

MUST BE POSTED IN AREA ACCESSIBLE TO PUBLIC

Betty P. Beville
Director of Finance

NOTICE

License issued subject
to compliance with all
pertinent city codes.

STATE OF Alabama

COUNTY OF Jefferson

AFFIDAVIT OF IMMIGRATION COMPLIANCE

Dianne R. Sewell (print name) being duly sworn, deposes and says:

1. My name is Dianne R. Sewell (print name). I am over the age of twenty-one (21). I am employed as VP Accounting/HR (print title) with Southland International Trucks, Inc. (print Company name) (hereinafter the "Company") who is a contractor, subcontractor, supplier, service provider or vendor with employees in the State of Alabama. In that capacity, I have personal knowledge of the facts stated in this Affidavit and a good faith belief that the Company is in compliance with the Immigration Reform and Control Act of 1986 and Beason-Hammon Alabama Taxpayer and Citizen Protection Act (hereinafter the "Act"). This Affidavit is given in connection with a good faith effort immigration compliance self-review or an independent outside review, in accordance with the Immigration Reform and Control Act of 1986, of the Company's immigration compliance.

2. The Company has not and does not knowingly employ, hire for employment, or continue to employ any unauthorized aliens. Further, the Company has no reason to believe that it has employed, hired for employment, or continues to employ any unauthorized aliens. The Company hereby certifies that it has made a good faith effort in accordance with the Immigration Reform and Control Act of 1986 to verify the employment eligibility and identity of all current employees.

3. The Company is presently enrolled in the E-Verify Program and shall verify every employee that is required to be verified according to the Immigration Reform and Control Act of 1986 and the Act. Attached to this Affidavit is the E-Verify Program for Employment Verification Memorandum of Understanding establishing that the Company is enrolled in the E-Verify Program.

4. The Company has, in good faith, complied with the Act with respect to verifying that it has a correctly completed I-9 for each of its current employees and it is in compliance with the Immigration Reform and Control Act of 1986, as well as all other provisions of the Act.

5. The Company affirms that it is providing written notice to its contractors, subcontractors, suppliers, service providers or vendors (hereinafter referred to as "Subcontractors"), who are in any manner involved with the Company's Projects or Contracts in the State of Alabama, of their immigration compliance obligations and will obtain from each Subcontractor and retain in its files, an Affidavit of Immigration Compliance with the attached E-Verify Program for Employment Verification Memorandum of Understanding establishing that the Subcontractor is enrolled in the E-Verify Program. If requested, the Company will make a copy of each Subcontractors Affidavit of Immigration Compliance available, or as may be required in any audit of the immigration compliance efforts of the Company

I have read the above AFFIDAVIT OF IMMIGRATION COMPLIANCE and it is true and correct to the best of my knowledge.

[Signature] (sign name)
Dianne R. Sewell (print name)

STATE OF Alabama

COUNTY OF Jefferson

I, the undersigned, Notary Public in and for said County in said State, hereby certify that Dianne R. Sewell (print name), who serves in the position of VP Accounting/HR (print title) for Southland International Trucks, Inc. (print Company name) has signed the foregoing instrument and who, personally known to me, acknowledged before me on this day that, being informed of the contents of the instrument, and with full authority, did execute the same voluntarily for and as the act of said Dianne R. Sewell (print name).

[Signature]
SIGNATURE AND SEAL OF NOTARY PUBLIC
(SEAL) My Commission Expires: 12/31/15

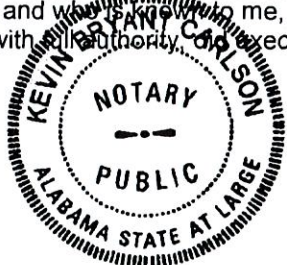

Company ID Number: 407682

THE E-VERIFY PROGRAM FOR EMPLOYMENT VERIFICATION MEMORANDUM OF UNDERSTANDING

ARTICLE I

PURPOSE AND AUTHORITY

This Memorandum of Understanding (MOU) sets forth the points of agreement between the Department of Homeland Security (DHS) and Southland International Trucks, Inc. (Employer) regarding the Employer's participation in the Employment Eligibility Verification Program (E-Verify). This MOU explains certain features of the E-Verify program and enumerates specific responsibilities of DHS, the Social Security Administration (SSA), and the Employer. E-Verify is a program that electronically confirms an employee's eligibility to work in the United States after completion of the Employment Eligibility Verification Form (Form I-9). For covered government contractors, E-Verify is used to verify the employment eligibility of all newly hired employees and all existing employees assigned to Federal contracts or to verify the entire workforce if the contractor so chooses.

Authority for the E-Verify program is found in Title IV, Subtitle A, of the Illegal Immigration Reform and Immigrant Responsibility Act of 1996 (IIRIRA), Pub. L. 104-208, 110 Stat. 3009, as amended (8 U.S.C. § 1324a note). Authority for use of the E-Verify program by Federal contractors and subcontractors covered by the terms of Subpart 22.18, "Employment Eligibility Verification", of the Federal Acquisition Regulation (FAR) (hereinafter referred to in this MOU as a "Federal contractor with the FAR E-Verify clause") to verify the employment eligibility of certain employees working on Federal contracts is also found in Subpart 22.18 and in Executive Order 12989, as amended.

ARTICLE II

FUNCTIONS TO BE PERFORMED

A. RESPONSIBILITIES OF SSA

1. SSA agrees to provide the Employer with available information that allows the Employer to confirm the accuracy of Social Security Numbers provided by all employees verified under this MOU and the employment authorization of U.S. citizens.
2. SSA agrees to provide to the Employer appropriate assistance with operational problems that may arise during the Employer's participation in the E-Verify program. SSA agrees to provide the Employer with names, titles, addresses, and telephone numbers of SSA representatives to be contacted during the E-Verify process.
3. SSA agrees to safeguard the information provided by the Employer through the E-Verify program procedures, and to limit access to such information, as is appropriate by law, to individuals responsible for the verification of Social Security Numbers and for evaluation of the E-Verify program or such other persons or entities who may be authorized by SSA as governed

Company ID Number: 407682

by the Privacy Act (5 U.S.C. § 552a), the Social Security Act (42 U.S.C. 1306(a)), and SSA regulations (20 CFR Part 401).

4. SSA agrees to provide a means of automated verification that is designed (in conjunction with DHS's automated system if necessary) to provide confirmation or tentative nonconfirmation of U.S. citizens' employment eligibility within 3 Federal Government work days of the initial inquiry.

5. SSA agrees to provide a means of secondary verification (including updating SSA records as may be necessary) for employees who contest SSA tentative nonconfirmations that is designed to provide final confirmation or nonconfirmation of U.S. citizens' employment eligibility and accuracy of SSA records for both citizens and non-citizens within 10 Federal Government work days of the date of referral to SSA, unless SSA determines that more than 10 days may be necessary. In such cases, SSA will provide additional verification instructions.

B. RESPONSIBILITIES OF DHS

1. After SSA verifies the accuracy of SSA records for employees through E-Verify, DHS agrees to provide the Employer access to selected data from DHS's database to enable the Employer to conduct, to the extent authorized by this MOU:

- Automated verification checks on employees by electronic means, and
- Photo verification checks (when available) on employees.

2. DHS agrees to provide to the Employer appropriate assistance with operational problems that may arise during the Employer's participation in the E-Verify program. DHS agrees to provide the Employer names, titles, addresses, and telephone numbers of DHS representatives to be contacted during the E-Verify process.

3. DHS agrees to make available to the Employer at the E-Verify Web site and on the E-Verify Web browser, instructional materials on E-Verify policies, procedures and requirements for both SSA and DHS, including restrictions on the use of E-Verify. DHS agrees to provide training materials on E-Verify.

4. DHS agrees to provide to the Employer a notice, which indicates the Employer's participation in the E-Verify program. DHS also agrees to provide to the Employer anti-discrimination notices issued by the Office of Special Counsel for Immigration-Related Unfair Employment Practices (OSC), Civil Rights Division, U.S. Department of Justice.

5. DHS agrees to issue the Employer a user identification number and password that permits the Employer to verify information provided by employees with DHS's database.

6. DHS agrees to safeguard the information provided to DHS by the Employer, and to limit access to such information to individuals responsible for the verification of employees' employment eligibility and for evaluation of the E-Verify program, or to such other persons or entities as may be authorized by applicable law. Information will be used only to verify the accuracy of Social Security Numbers and employment eligibility, to enforce the Immigration and

Company ID Number: 407682

Nationality Act (INA) and Federal criminal laws, and to administer Federal contracting requirements.

7. DHS agrees to provide a means of automated verification that is designed (in conjunction with SSA verification procedures) to provide confirmation or tentative nonconfirmation of employees' employment eligibility within 3 Federal Government work days of the initial inquiry.

8. DHS agrees to provide a means of secondary verification (including updating DHS records as may be necessary) for employees who contest DHS tentative nonconfirmations and photo non-match tentative nonconfirmations that is designed to provide final confirmation or nonconfirmation of the employees' employment eligibility within 10 Federal Government work days of the date of referral to DHS, unless DHS determines that more than 10 days may be necessary. In such cases, DHS will provide additional verification instructions.

C. RESPONSIBILITIES OF THE EMPLOYER

1. The Employer agrees to display the notices supplied by DHS in a prominent place that is clearly visible to prospective employees and all employees who are to be verified through the system.

2. The Employer agrees to provide to the SSA and DHS the names, titles, addresses, and telephone numbers of the Employer representatives to be contacted regarding E-Verify.

3. The Employer agrees to become familiar with and comply with the most recent version of the E-Verify User Manual.

4. The Employer agrees that any Employer Representative who will perform employment verification queries will complete the E-Verify Tutorial before that individual initiates any queries.

A. The Employer agrees that all Employer representatives will take the refresher tutorials initiated by the E-Verify program as a condition of continued use of E-Verify.

B. Failure to complete a refresher tutorial will prevent the Employer from continued use of the program.

5. The Employer agrees to comply with current Form I-9 procedures, with two exceptions:

- If an employee presents a "List B" identity document, the Employer agrees to only accept "List B" documents that contain a photo. (List B documents identified in 8 C.F.R. § 274a.2(b)(1)(B)) can be presented during the Form I-9 process to establish identity.) If an employee objects to the photo requirement for religious reasons, the Employer should contact E-Verify at 888-464-4218.

- If an employee presents a DHS Form I-551 (Permanent Resident Card) or Form I-766 (Employment Authorization Document) to complete the Form I-9, the Employer agrees to make a photocopy of the document and to retain the photocopy with the employee's Form I-9. The photocopy must be of sufficient quality to allow for verification of the photo

Company ID Number: 407682

and written information. The employer will use the photocopy to verify the photo and to assist DHS with its review of photo non-matches that are contested by employees. Note that employees retain the right to present any List A, or List B and List C, documentation to complete the Form I-9. DHS may in the future designate other documents that activate the photo screening tool.

6. The Employer understands that participation in E-Verify does not exempt the Employer from the responsibility to complete, retain, and make available for inspection Forms I-9 that relate to its employees, or from other requirements of applicable regulations or laws, including the obligation to comply with the antidiscrimination requirements of section 274B of the INA with respect to Form I-9 procedures, except for the following modified requirements applicable by reason of the Employer's participation in E-Verify: (1) identity documents must have photos, as described in paragraph 5 above; (2) a rebuttable presumption is established that the Employer has not violated section 274A(a)(1)(A) of the Immigration and Nationality Act (INA) with respect to the hiring of any individual if it obtains confirmation of the identity and employment eligibility of the individual in good faith compliance with the terms and conditions of E-Verify; (3) the Employer must notify DHS if it continues to employ any employee after receiving a final nonconfirmation, and is subject to a civil money penalty between \$550 and \$1,100 for each failure to notify DHS of continued employment following a final nonconfirmation; (4) the Employer is subject to a rebuttable presumption that it has knowingly employed an unauthorized alien in violation of section 274A(a)(1)(A) if the Employer continues to employ an employee after receiving a final nonconfirmation; and (5) no person or entity participating in E-Verify is civilly or criminally liable under any law for any action taken in good faith based on information provided through the confirmation system. DHS reserves the right to conduct Form I-9 and E-Verify system compliance inspections during the course of E-Verify, as well as to conduct any other enforcement activity authorized by law.

7. The Employer agrees to initiate E-Verify verification procedures for new employees within 3 Employer business days after each employee has been hired (but after the Form I-9 has been completed), and to complete as many (but only as many) steps of the E-Verify process as are necessary according to the E-Verify User Manual, or in the case of Federal contractors with the FAR E-Verify clause, the E-Verify User Manual for Federal Contractors. The Employer is prohibited from initiating verification procedures before the employee has been hired and the Form I-9 completed. If the automated system to be queried is temporarily unavailable, the 3-day time period is extended until it is again operational in order to accommodate the Employer's attempting, in good faith, to make inquiries during the period of unavailability. Employers may initiate verification by notating the Form I-9 in circumstances where the employee has applied for a Social Security Number (SSN) from the SSA and is waiting to receive the SSN, provided that the Employer performs an E-Verify employment verification query using the employee's SSN as soon as the SSN becomes available.

8. The Employer agrees not to use E-Verify procedures for pre-employment screening of job applicants, in support of any unlawful employment practice, or for any other use not authorized by this MOU. Employers must use E-Verify for all new employees, unless an Employer is a Federal contractor that qualifies for the exceptions described in Article II.D.1.c. Except as provided in Article II.D, the Employer will not verify selectively and will not verify employees hired before the effective date of this MOU. The Employer understands that if the Employer



Company ID Number: 407682

uses the E-Verify system for any purpose other than as authorized by this MOU, the Employer may be subject to appropriate legal action and termination of its access to SSA and DHS information pursuant to this MOU.

9. The Employer agrees to follow appropriate procedures (see Article III. below) regarding tentative nonconfirmations, including notifying employees in private of the finding and providing them written notice of the findings, providing written referral instructions to employees, allowing employees to contest the finding, and not taking adverse action against employees if they choose to contest the finding. Further, when employees contest a tentative nonconfirmation based upon a photo non-match, the Employer is required to take affirmative steps (see Article III.B. below) to contact DHS with information necessary to resolve the challenge.

10. The Employer agrees not to take any adverse action against an employee based upon the employee's perceived employment eligibility status while SSA or DHS is processing the verification request unless the Employer obtains knowledge (as defined in 8 C.F.R. § 274a.1(l)) that the employee is not work authorized. The Employer understands that an initial inability of the SSA or DHS automated verification system to verify work authorization, a tentative nonconfirmation, a case in continuance (indicating the need for additional time for the government to resolve a case), or the finding of a photo non-match, does not establish, and should not be interpreted as evidence, that the employee is not work authorized. In any of the cases listed above, the employee must be provided a full and fair opportunity to contest the finding, and if he or she does so, the employee may not be terminated or suffer any adverse employment consequences based upon the employee's perceived employment eligibility status (including denying, reducing, or extending work hours, delaying or preventing training, requiring an employee to work in poorer conditions, refusing to assign the employee to a Federal contract or other assignment, or otherwise subjecting an employee to any assumption that he or she is unauthorized to work) until and unless secondary verification by SSA or DHS has been completed and a final nonconfirmation has been issued. If the employee does not choose to contest a tentative nonconfirmation or a photo non-match or if a secondary verification is completed and a final nonconfirmation is issued, then the Employer can find the employee is not work authorized and terminate the employee's employment. Employers or employees with questions about a final nonconfirmation may call E-Verify at 1-888-464-4218 or OSC at 1-800-255-8155 or 1-800-237-2515 (TDD).

11. The Employer agrees to comply with Title VII of the Civil Rights Act of 1964 and section 274B of the INA, as applicable, by not discriminating unlawfully against any individual in hiring, firing, or recruitment or referral practices because of his or her national origin or, in the case of a protected individual as defined in section 274B(a)(3) of the INA, because of his or her citizenship status. The Employer understands that such illegal practices can include selective verification or use of E-Verify except as provided in part D below, or discharging or refusing to hire employees because they appear or sound "foreign" or have received tentative nonconfirmations. The Employer further understands that any violation of the unfair immigration-related employment practices provisions in section 274B of the INA could subject the Employer to civil penalties, back pay awards, and other sanctions, and violations of Title VII could subject the Employer to back pay awards, compensatory and punitive damages. Violations of either section 274B of the INA or Title VII may also lead to the termination of its participation in E-



Company ID Number: 407682

Verify. If the Employer has any questions relating to the anti-discrimination provision, it should contact OSC at 1-800-255-8155 or 1-800-237-2515 (TDD).

12. The Employer agrees to record the case verification number on the employee's Form I-9 or to print the screen containing the case verification number and attach it to the employee's Form I-9.

13. The Employer agrees that it will use the information it receives from SSA or DHS pursuant to E-Verify and this MOU only to confirm the employment eligibility of employees as authorized by this MOU. The Employer agrees that it will safeguard this information, and means of access to it (such as PINS and passwords) to ensure that it is not used for any other purpose and as necessary to protect its confidentiality, including ensuring that it is not disseminated to any person other than employees of the Employer who are authorized to perform the Employer's responsibilities under this MOU, except for such dissemination as may be authorized in advance by SSA or DHS for legitimate purposes.

14. The Employer acknowledges that the information which it receives from SSA is governed by the Privacy Act (5 U.S.C. § 552a(i)(1) and (3)) and the Social Security Act (42 U.S.C. 1306(a)), and that any person who obtains this information under false pretenses or uses it for any purpose other than as provided for in this MOU may be subject to criminal penalties.

15. The Employer agrees to cooperate with DHS and SSA in their compliance monitoring and evaluation of E-Verify, including by permitting DHS and SSA, upon reasonable notice, to review Forms I-9 and other employment records and to interview it and its employees regarding the Employer's use of E-Verify, and to respond in a timely and accurate manner to DHS requests for information relating to their participation in E-Verify.

D. RESPONSIBILITIES OF FEDERAL CONTRACTORS WITH THE FAR E-VERIFY CLAUSE

1. The Employer understands that if it is a subject to the employment verification terms in Subpart 22.18 of the FAR, it must verify the employment eligibility of any existing employee assigned to the contract and all new hires, as discussed in the Supplemental Guide for Federal Contractors. Once an employee has been verified through E-Verify by the Employer, the Employer may not reverify the employee through E-Verify.

a. Federal contractors with the FAR E-Verify clause agree to become familiar with and comply with the most recent versions of the E-Verify User Manual for Federal Contractors and the E-Verify Supplemental Guide for Federal Contractors.

b. Federal contractors with the FAR E-Verify clause agree to complete a tutorial for Federal contractors with the FAR E-Verify clause.

c. Federal contractors with the FAR E-Verify clause not enrolled at the time of contract award: An Employer that is not enrolled in E-Verify at the time of a contract award must enroll as a Federal contractor with the FAR E-Verify clause in E-Verify within 30 calendar days of contract award and, within 90 days of enrollment, begin to use E-Verify to initiate verification of employment eligibility of new hires of the Employer who are working in the United States,



Company ID Number: 407682

whether or not assigned to the contract. Once the Employer begins verifying new hires, such verification of new hires must be initiated within 3 business days after the date of hire. Once enrolled in E-Verify as a Federal contractor with the FAR E-Verify clause, the Employer must initiate verification of employees assigned to the contract within 90 calendar days from the time of enrollment in the system and after the date and selecting which employees will be verified in E-Verify or within 30 days of an employee's assignment to the contract, whichever date is later.

d. Employers that are already enrolled in E-Verify at the time of a contract award but are not enrolled in the system as a Federal contractor with the FAR E-Verify clause: Employers enrolled in E-Verify for 90 days or more at the time of a contract award must use E-Verify to initiate verification of employment eligibility for new hires of the Employer who are working in the United States, whether or not assigned to the contract, within 3 business days after the date of hire. Employers enrolled in E-Verify as other than a Federal contractor with the FAR E-Verify clause, must update E-Verify to indicate that they are a Federal contractor with the FAR E-Verify clause within 30 days after assignment to the contract. If the Employer is enrolled in E-Verify for 90 calendar days or less at the time of contract award, the Employer must, within 90 days of enrollment, begin to use E-Verify to initiate verification of new hires of the contractor who are working in the United States, whether or not assigned to the contract. Such verification of new hires must be initiated within 3 business days after the date of hire. An Employer enrolled as a Federal contractor with the FAR E-Verify clause in E-Verify must initiate verification of each employee assigned to the contract within 90 calendar days after date of contract award or within 30 days after assignment to the contract, whichever is later.

e. Institutions of higher education, State, local and tribal governments and sureties: Federal contractors with the FAR E-Verify clause that are institutions of higher education (as defined at 20 U.S.C. 1001(a)), State or local governments, governments of Federally recognized Indian tribes, or sureties performing under a takeover agreement entered into with a Federal agency pursuant to a performance bond may choose to only verify new and existing employees assigned to the Federal contract. Such Federal contractors with the FAR E-Verify clause may, however, elect to verify all new hires, and/or all existing employees hired after November 6, 1986. The provisions of Article II.D, paragraphs 1.a and 1.b of this MOU providing timeframes for initiating employment verification of employees assigned to a contract apply to such institutions of higher education, State, local and tribal governments, and sureties.

f. Verification of all employees: Upon enrollment, Employers who are Federal contractors with the FAR E-Verify clause may elect to verify employment eligibility of all existing employees working in the United States who were hired after November 6, 1986, instead of verifying only new employees and those existing employees assigned to a covered Federal contract. After enrollment, Employers must elect to do so only in the manner designated by DHS and initiate E-Verify verification of all existing employees within 180 days after the election.

g. Form I-9 procedures for existing employees of Federal contractors with the FAR E-Verify clause: Federal contractors with the FAR E-Verify clause may choose to complete new Forms I-9 for all existing employees other than those that are completely exempt from this process. Federal contractors with the FAR E-Verify clause may also update previously completed Forms I-9 to initiate E-Verify verification of existing employees who are not completely exempt as long as that Form I-9 is complete (including the SSN), complies with

Company ID Number: 407682

Article II.C.5, the employee's work authorization has not expired, and the Employer has reviewed the information reflected in the Form I-9 either in person or in communications with the employee to ensure that the employee's stated basis in section 1 of the Form I-9 for work authorization has not changed (including, but not limited to, a lawful permanent resident alien having become a naturalized U.S. citizen). If the Employer is unable to determine that the Form I-9 complies with Article II.C.5, if the employee's basis for work authorization as attested in section 1 has expired or changed, or if the Form I-9 contains no SSN or is otherwise incomplete, the Employer shall complete a new I-9 consistent with Article II.C.5, or update the previous I-9 to provide the necessary information. If section 1 of the Form I-9 is otherwise valid and up-to-date and the form otherwise complies with Article II.C.5, but reflects documentation (such as a U.S. passport or Form I-551) that expired subsequent to completion of the Form I-9, the Employer shall not require the production of additional documentation, or use the photo screening tool described in Article II.C.5, subject to any additional or superseding instructions that may be provided on this subject in the Supplemental Guide for Federal Contractors. Nothing in this section shall be construed to require a second verification using E-Verify of any assigned employee who has previously been verified as a newly hired employee under this MOU, or to authorize verification of any existing employee by any Employer that is not a Federal contractor with the FAR E-Verify clause.

2. The Employer understands that if it is a Federal contractor with the FAR E-Verify clause, its compliance with this MOU is a performance requirement under the terms of the Federal contract or subcontract, and the Employer consents to the release of information relating to compliance with its verification responsibilities under this MOU to contracting officers or other officials authorized to review the Employer's compliance with Federal contracting requirements.

ARTICLE III

REFERRAL OF INDIVIDUALS TO SSA AND DHS

A. REFERRAL TO SSA

1. If the Employer receives a tentative nonconfirmation issued by SSA, the Employer must print the notice as directed by the E-Verify system and provide it to the employee so that the employee may determine whether he or she will contest the tentative nonconfirmation. The Employer must review the tentative nonconfirmation with the employee in private.

2. The Employer will refer employees to SSA field offices only as directed by the automated system based on a tentative nonconfirmation, and only after the Employer records the case verification number, reviews the input to detect any transaction errors, and determines that the employee contests the tentative nonconfirmation. The Employer will transmit the Social Security Number to SSA for verification again if this review indicates a need to do so. The Employer will determine whether the employee contests the tentative nonconfirmation as soon as possible after the Employer receives it.

3. If the employee contests an SSA tentative nonconfirmation, the Employer will provide the employee with a system-generated referral letter and instruct the employee to visit an SSA office within 8 Federal Government work days. SSA will electronically transmit the result of the referral to the Employer within 10 Federal Government work days of the referral unless it

Company ID Number: 407682

determines that more than 10 days is necessary. The Employer agrees to check the E-Verify system regularly for case updates.

4. The Employer agrees not to ask the employee to obtain a printout from the Social Security Number database (the Numident) or other written verification of the Social Security Number from the SSA.

B. REFERRAL TO DHS

1. If the Employer receives a tentative nonconfirmation issued by DHS, the Employer must print the tentative nonconfirmation notice as directed by the E-Verify system and provide it to the employee so that the employee may determine whether he or she will contest the tentative nonconfirmation. The Employer must review the tentative nonconfirmation with the employee in private.

2. If the Employer finds a photo non-match for an employee who provides a document for which the automated system has transmitted a photo, the employer must print the photo non-match tentative nonconfirmation notice as directed by the automated system and provide it to the employee so that the employee may determine whether he or she will contest the finding. The Employer must review the tentative nonconfirmation with the employee in private.

3. The Employer agrees to refer individuals to DHS only when the employee chooses to contest a tentative nonconfirmation received from DHS automated verification process or when the Employer issues a tentative nonconfirmation based upon a photo non-match. The Employer will determine whether the employee contests the tentative nonconfirmation as soon as possible after the Employer receives it.

4. If the employee contests a tentative nonconfirmation issued by DHS, the Employer will provide the employee with a referral letter and instruct the employee to contact DHS through its toll-free hotline (as found on the referral letter) within 8 Federal Government work days.

5. If the employee contests a tentative nonconfirmation based upon a photo non-match, the Employer will provide the employee with a referral letter to DHS. DHS will electronically transmit the result of the referral to the Employer within 10 Federal Government work days of the referral unless it determines that more than 10 days is necessary. The Employer agrees to check the E-Verify system regularly for case updates.

6. The Employer agrees that if an employee contests a tentative nonconfirmation based upon a photo non-match, the Employer will send a copy of the employee's Form I-551 or Form I-766 to DHS for review by:

- Scanning and uploading the document, or
- Sending a photocopy of the document by an express mail account (paid for at employer expense).

7. If the Employer determines that there is a photo non-match when comparing the photocopied List B document described in Article II.C.5 with the image generated in E-Verify, the Employer must forward the employee's documentation to DHS using one of the means described in the preceding paragraph, and allow DHS to resolve the case.

Company ID Number: 407682

ARTICLE IV

SERVICE PROVISIONS

SSA and DHS will not charge the Employer for verification services performed under this MOU. The Employer is responsible for providing equipment needed to make inquiries. To access E-Verify, an Employer will need a personal computer with Internet access.

ARTICLE V

PARTIES

A. This MOU is effective upon the signature of all parties, and shall continue in effect for as long as the SSA and DHS conduct the E-Verify program unless modified in writing by the mutual consent of all parties, or terminated by any party upon 30 days prior written notice to the others. Any and all system enhancements to the E-Verify program by DHS or SSA, including but not limited to the E-Verify checking against additional data sources and instituting new verification procedures, will be covered under this MOU and will not cause the need for a supplemental MOU that outlines these changes. DHS agrees to train employers on all changes made to E-Verify through the use of mandatory refresher tutorials and updates to the E-Verify User Manual, the E-Verify User Manual for Federal Contractors or the E-Verify Supplemental Guide for Federal Contractors. Even without changes to E-Verify, DHS reserves the right to require employers to take mandatory refresher tutorials. An Employer that is a Federal contractor with the FAR E-Verify clause may terminate this MOU when the Federal contract that requires its participation in E-Verify is terminated or completed. In such a circumstance, the Federal contractor with the FAR E-Verify clause must provide written notice to DHS. If an Employer that is a Federal contractor with the FAR E-Verify clause fails to provide such notice, that Employer will remain a participant in the E-Verify program, will remain bound by the terms of this MOU that apply to participants that are not Federal contractors with the FAR E-Verify clause, and will be required to use the E-Verify procedures to verify the employment eligibility of all newly hired employees.

B. Notwithstanding Article V, part A of this MOU, DHS may terminate this MOU if deemed necessary because of the requirements of law or policy, or upon a determination by SSA or DHS that there has been a breach of system integrity or security by the Employer, or a failure on the part of the Employer to comply with established procedures or legal requirements. The Employer understands that if it is a Federal contractor with the FAR E-Verify clause, termination of this MOU by any party for any reason may negatively affect its performance of its contractual responsibilities.

C. Some or all SSA and DHS responsibilities under this MOU may be performed by contractor(s), and SSA and DHS may adjust verification responsibilities between each other as they may determine necessary. By separate agreement with DHS, SSA has agreed to perform its responsibilities as described in this MOU.

Company ID Number: 407682

D. Nothing in this MOU is intended, or should be construed, to create any right or benefit, substantive or procedural, enforceable at law by any third party against the United States, its agencies, officers, or employees, or against the Employer, its agents, officers, or employees.

E. Each party shall be solely responsible for defending any claim or action against it arising out of or related to E-Verify or this MOU, whether civil or criminal, and for any liability wherefrom, including (but not limited to) any dispute between the Employer and any other person or entity regarding the applicability of Section 403(d) of IIRIRA to any action taken or allegedly taken by the Employer.

F. The Employer understands that the fact of its participation in E-Verify is not confidential information and may be disclosed as authorized or required by law and DHS or SSA policy, including but not limited to, Congressional oversight, E-Verify publicity and media inquiries, determinations of compliance with Federal contractual requirements, and responses to inquiries under the Freedom of Information Act (FOIA).

G. The foregoing constitutes the full agreement on this subject between DHS and the Employer.

H. The individuals whose signatures appear below represent that they are authorized to enter into this MOU on behalf of the Employer and DHS respectively.

E-Verify



Company ID Number: 407682

To be accepted as a participant in E-Verify, you should only sign the Employer's Section of the signature page. If you have any questions, contact E-Verify at 888-464-4218.

Employer Southland International Trucks, Inc.	
Dianne Sewell	
Name (Please Type or Print)	Title
Electronically Signed	04/11/2011
Signature	Date
Department of Homeland Security – Verification Division	
USCIS Verification Division	
Name (Please Type or Print)	Title
Electronically Signed	04/11/2011
Signature	Date

Information Required for the E-Verify Program

Information relating to your Company:

Company Name:	Southland International Trucks, Inc.
Company Facility Address:	200 Oxmoor Blvd
	Homewood, AL 35209
Company Alternate Address:	
County or Parish:	JEFFERSON
Employer Identification Number:	630832185

Company ID Number: 407682

North American Industry Classification Systems Code:	423
Administrator:	
Number of Employees:	100 to 499
Number of Sites Verified for:	5
Are you verifying for more than 1 site? If yes, please provide the number of sites verified for in each State:	
<ul style="list-style-type: none">• ALABAMA 5 site(s)	

Information relating to the Program Administrator(s) for your Company on policy questions or operational problems:

Name:	Dianne R Sewell	Fax Number:	(205) 380 - 9732
Telephone Number:	(205) 942 - 6226		
E-mail Address:	dsewell@southlandtrucks.com		
Name:	Diana D Allen	Fax Number:	(205) 380 - 9733
Telephone Number:	(205) 942 - 6226 ext. 2403		
E-mail Address:	dallen@southlandtrucks.com		

HX[®] SERIES



INTERNATIONAL[®] HX[®] SERIES.





HERE COMES THE BOOM!

Introducing the new International® HX® Series. Our latest, greatest, biggest, baddest, toughest, most premium, precision sledgehammer.

Built to endure, thrive and dominate any assignment, the HX Series can handle whatever you throw at it. And just like you, the HX Series can take it on the chin and keep moving forward until the job is pinned down into submission – all without breaking a sweat.





**SEVERE DUTY JOB?
MORE LIKE CHILD'S PLAY.**



The HX[®] Series has always been the go-to truck for the toughest applications. And now we've added the features and capabilities that take it to the next level. We designed our Extreme Duty cab to be even more premium with best-in-class interior space and materials designed to provide comfort and support mile after punishing mile. Now more TEM-friendly than ever, the HX Series features built-in Diamond Logic[®] multiplex technology and lift axle options installed at the factory.



BUILT AROUND YOU.



The business-end of any truck is actually behind the steering wheel.

It's the drivers that complete the job and we made sure it's the drivers who get rewarded with our available Diamond Elite interior featuring top-of-the-line materials and equipment like premium Isringhausen seats for best-in-

class comfort. Engineered for productivity, the HX® Series includes a programmable digital gauge cluster so drivers can keep the information they want front and center - including the status of the lift axles.

The standard gauge cluster includes a customizable digital display which provides a wealth of information for the driver, including:

- ▶ Real-time fuel economy
- ▶ Axle load*
- ▶ Custom gauge settings*
- ▶ Safety indicators*
- ▶ Digital speedometer
- ▶ Tire pressure*

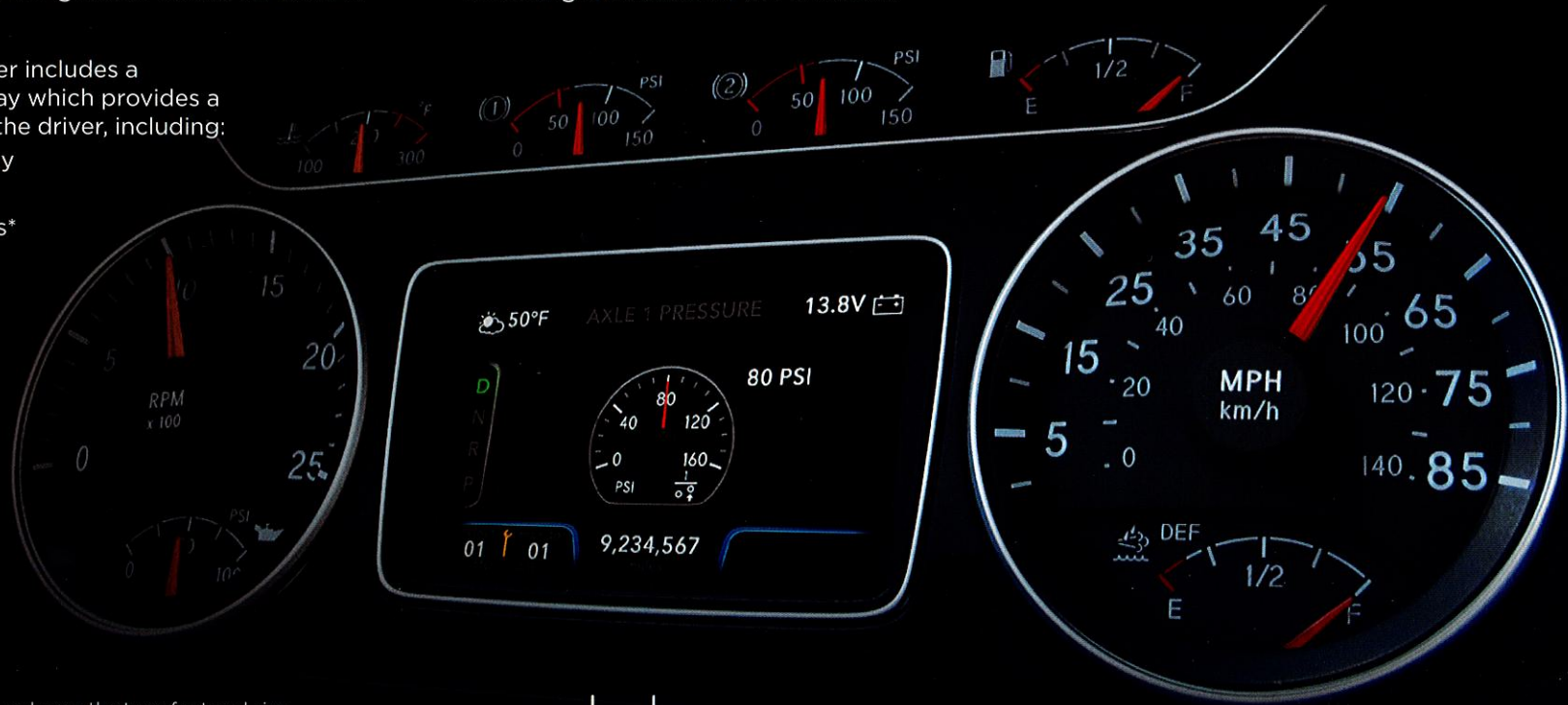

The color, illumination, legibility and even the type font and size of gauges is designed to deliver optimal viewing in varying light conditions, maximizing alertness and minimizing eye fatigue.



*When added with optional feature code for required sensors



**RULE #1: ALWAYS
TAKE CARE OF
THE DRIVER.**



A SEAT FIT FOR A KING-OF-THE-ROAD



A premium truck demands a premium cab. And just as there's no truck that can out-work the HX® Series, nobody offers a more comfortable interior. The new Diamond Elite trim level provides best-in-class comfort - providing the ideal temperature, support and seating position for the most discerning drivers.

A well-designed seat should help the driver stay fresh and alert. That's why the Diamond Elite seat in the HX® Series has so many adjustments. It can be now be tailored to suit drivers of all shapes and sizes, incorporating features normally only found in luxury automobiles.

Seat cushion adjustment

- ▶ Controls the bottom seat cushion length and tilt
- ▶ Helps accommodate drivers of all heights by distributing leg support

Fore/Aft Isolator & Adjustable Shock Absorber

- ▶ Sometimes known as a "chugger," the fore / aft Isolator dampens the movement/jostling caused by various loads
- ▶ The Adjustable Shock Absorber can vary the stiffness of the ride to match the road profile

Seat Length and Height Adjustment

- ▶ The height and length adjustment allows drivers to find the perfect driving position
- ▶ Pneumatic Lumbar and Side Bolster Supports
- ▶ The 2-chamber lumbar adjustment is especially appreciated by drivers who spend long hours behind the wheel
- ▶ Pneumatic side bolsters provide additional upper body support and helps the the driver sit more upright

Seat Backrest and Armrest

- ▶ The adjustable backrest provides up to 52 degrees of range
- ▶ The armrest is designed to provide support for drivers of various sizes

Seat Climate Control

- ▶ Active seat ventilation helps keep drivers and passengers comfortable on a long drive in any weather
- ▶ Two fans draw fresh cabin air into the seats allowing the air to circulate and keeping perspiration to a minimum
- ▶ A sensor is located in both the seat and backrest to ensure uniform temperature distribution

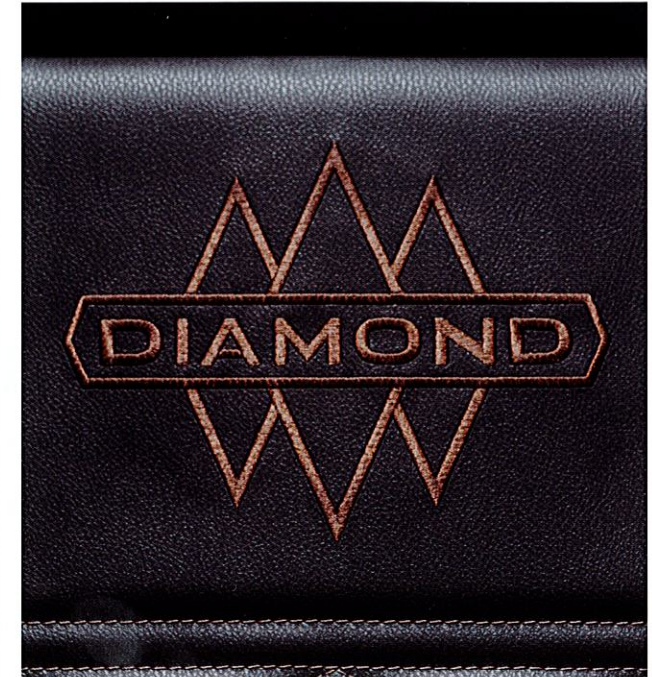

"Every little creature comfort you can get to help make the operation of the truck easier, it's a big deal for the driver."

- Group Ready Mix Manager Justin Tucker

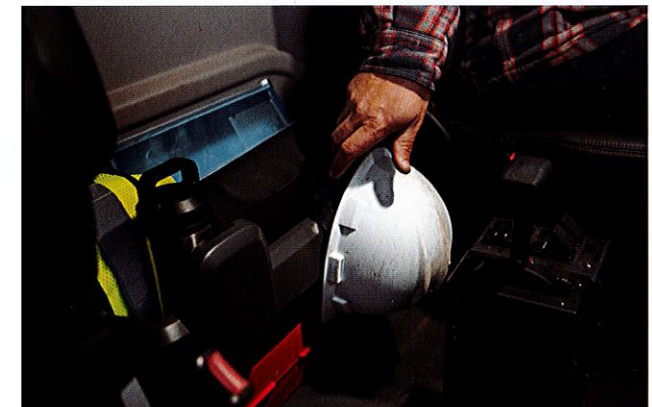



STONE SLINGER™

ULTRA 18
STONE SLINGER

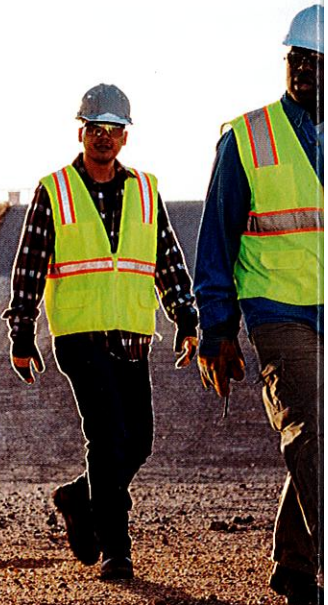

A 45-TON ROLLING BILLBOARD.



A new cab means new possibilities including a new integrated character line on the body sides — perfect for pin striping and custom graphics. Functional chrome external air cleaners are available along with chrome pedestal mirrors, grille surround and bumper. LED daytime running lights make a bold statement and a long list of stainless-steel components are available including a visor, bug deflector and more.



READY TO RUMBLE.

The new HX® Series is now available with a dynamic range of factory-installed lift axles, pre-certified and ready to get to work. Spacing accommodations can be made for various bridge laws and the controls for the lift axle are now integrated into the wing panel through Diamond Logic - freeing up the space between the front seats for other important items - like coffee mugs and hard hats.



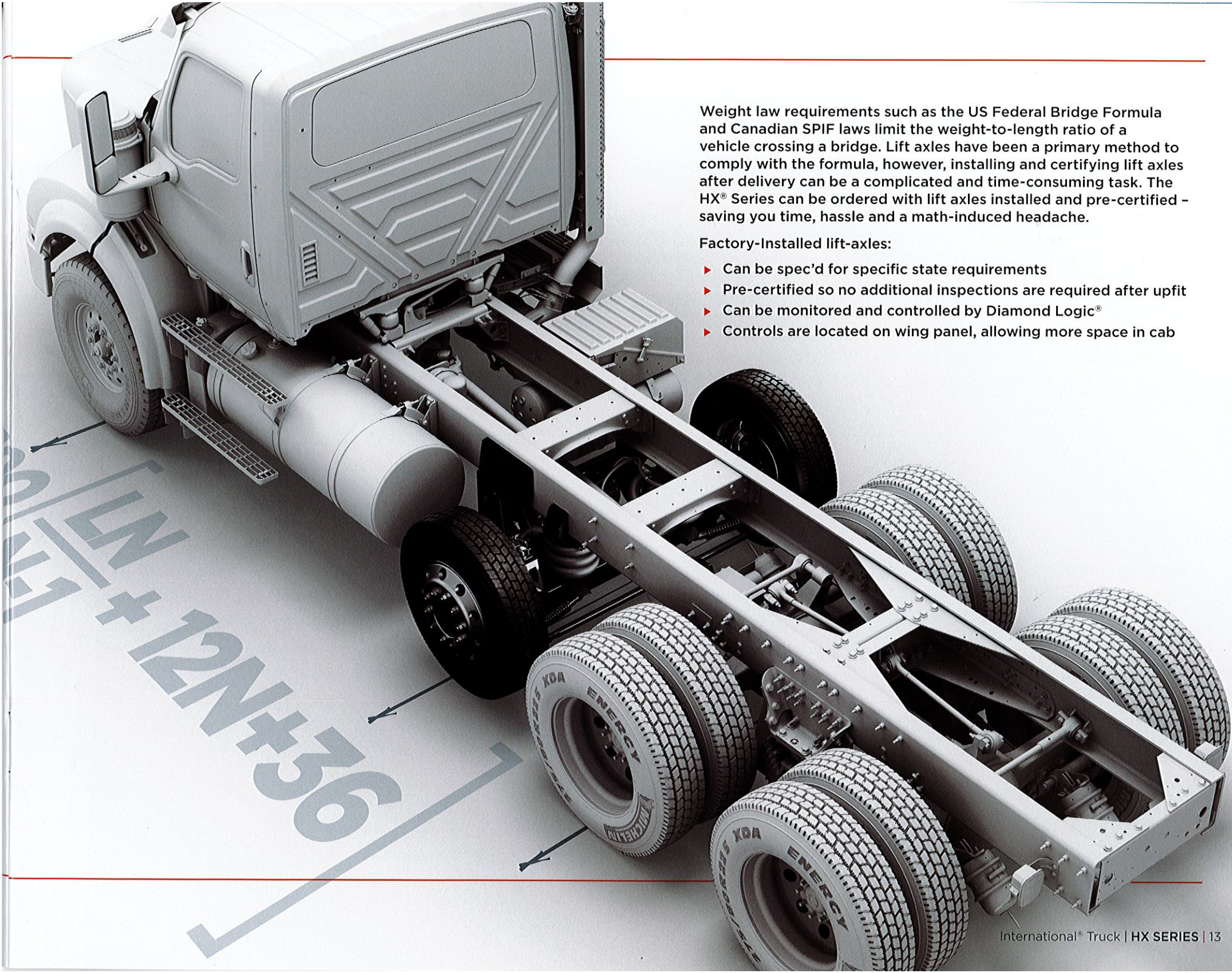

Weight law requirements such as the US Federal Bridge Formula and Canadian SPIF laws limit the weight-to-length ratio of a vehicle crossing a bridge. Lift axles have been a primary method to comply with the formula, however, installing and certifying lift axles after delivery can be a complicated and time-consuming task. The HX® Series can be ordered with lift axles installed and pre-certified - saving you time, hassle and a math-induced headache.

Factory-Installed lift-axes:

- ▶ Can be spec'd for specific state requirements
- ▶ Pre-certified so no additional inspections are required after upfit
- ▶ Can be monitored and controlled by Diamond Logic®
- ▶ Controls are located on wing panel, allowing more space in cab



Extreme Duty Cab

The cab of the new HX[®] Series is made of tough, durable, easy-to-repair steel. New advancements in manufacturing mean that steel can now offer the same corrosion resistance as aluminum without a weight penalty - not to mention greater strength. The steel cab allows for a larger, quieter interior with air-tight, water-tight seals. Beefy door hinges and reinforced B-Pillars (to support the cab-mounted exhaust) are just a few more examples of the endurance-boosting features found on the new HX Series.

ChemGuard Coating

This inter-reactive, chrome-zinc phosphate coating is applied on top of the galvanized steel. Its self-healing properties allow the surface to be scratched, cut or perforated and still maintain corrosion protection.

Line-X Coating

This polyurethane and polyurea formulation has earned industry respect for its durable, long-lasting and high-performance qualities. Designed to protect against abrasion, corrosion and impact, this OEM-grade coating can be found on over 4 million pickup bedliners.

Reinforced B-Pillars

For extra cab strength and to support the new cab-mounted exhaust option, every HX Series includes reinforced B-Pillars.



ChemGuard Coating

Line-X Coating

Reinforced
B-Pillars



A No-Compromise Anti-Corrosion Approach

To provide the strength and easy-to-repair qualities of steel with the corrosion resistance severe-duty customers demand, the Extreme Duty cab of the HX® Series features a special paint and coating process designed with endurance in mind.

Corrosion Protection Process:

1. Stamped galvanized steel
2. Custom-engineered caustic and surfactant formula cleans and preps the steel
3. Proprietary tri-metal (nickel, zinc, manganese) phosphate blend provides robust corrosion protection and the first level of paint adhesion
4. Epoxy-based electrodeposition primer, or E-Coat is applied.
This covers and seals the entire exposed metal surface of the cab
5. Acrylic basecoat
6. Urethane clearcoat

E-Coat Paint Process

Clearcoat

Basecoat

E-coat

Galvanized Steel

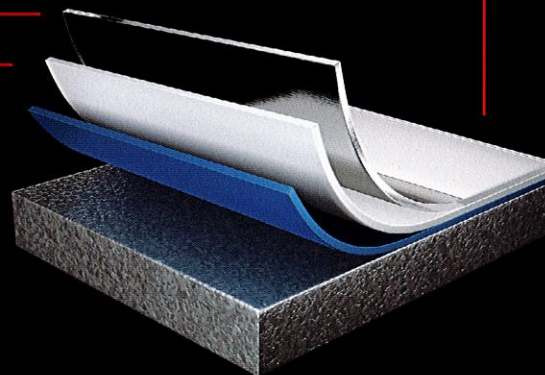

STRUCTURAL ENHANCEMENTS

After extensive CAD modeling and rigorous testing, International engineers made various structural enhancements to the cab to achieve even greater toughness.

Strut Brace (sleeper only)

- ▶ A new strut brace improves dash endurance.



Sled Runners (day cab and sleeper)

- ▶ The HX® Series cab variants feature high strength steel sled runners for improved durability





AS COMFORTABLE ON THE SITE AS YOU ARE GETTING THERE.

Getting to the worksite is only half the job. Being productive at the worksite is what pays the bills. The HX[®] Series makes this task as easy as possible by providing industry-leading HVAC, expansive driver sight lines and impressive, obstacle-avoiding maneuverability - not to mention its spacious and accommodating cab - a cab you can work in all day long without feeling cramped.



25 MINUTES

DEFROST LIKE NOBODY'S BUSINESS.

The quicker you can see, the quicker you can get to work. We've made great strides in improving the defrost power of the HX Series over the years, but nothing like this. Our internal testing cleared the entire windshield (cold soaked at zero degrees overnight) in 25 minutes - despite the fact that it's now 400 sq. in. bigger.

WORKSITE DURABILITY.

The worksite can be a rough place and very few vehicles leave without some kind of battle wound. But if the truck is made out of the right materials, the repair can be relatively painless. Compared to aluminum, repairing steel body panels like those found on the new HX Series is a piece of cake. Plus, the new DCPD (Dicyclopentadiene) three-piece hood is stronger than fiberglass and resists cracking over the life of the truck.



EASIER SLEEPER ACCESS.

Improved driver pivot access, seat recline, and greater leg room and a redesigned lower console make it easier to turn in for the night.



ROOM TO APPRECIATE.

The door panels help increase hip and elbow room while providing a more comfortable place to rest your arm. The full-grip interior handle makes doors easier to open and close, while the door pockets offer easier access to maps or paperwork.

SEE THAT IT'S DONE.

Good visibility at the worksite is crucial in order to complete the job safely and efficiently. A new, sloped hood design, larger windshield, and precision halogen headlamps all contribute to provide outstanding visibility.

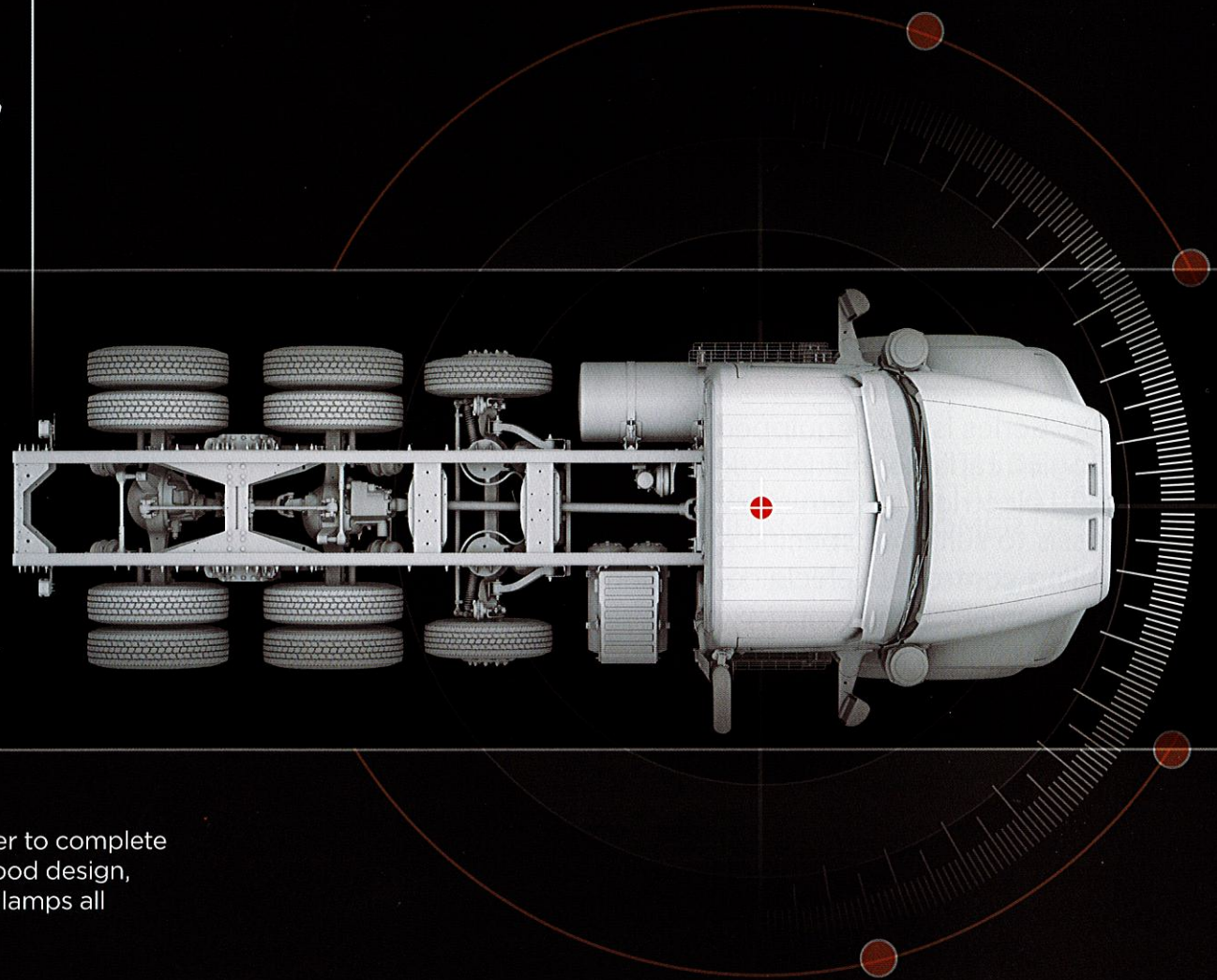



A TEM-READY TASK MASTER.

The new HX[®] Series is now equipped with the International Diamond Logic[®] capable multiplexed electrical system. This powerful electrical system allows you to customize the vehicle chassis to suit your specific application needs enabling control of vehicle components and body equipment.

Combined with the clean CA frame rails, factory-installed lift axles and flexible component locations, the HX Series allows Truck Equipment Manufacturer/Body Builders (TEMs) to create the ideal solution for your application needs.



Body Company Benefits—Mixer:

- ▶ Specific cross-member location to accommodate mixer PTO pump
- ▶ Factory-installed transition brackets for body mounting
- ▶ Inverted after-frame cross members for booster axle ram clearance

Body Company Benefits—Crane:

- ▶ Customized frame ladder and component locations to meet body packaging requirements
- ▶ Available integral front frame extensions
- ▶ Single 1/2", 3.5 million RBM straight frame rail provides high strength for high capacity crane applications

Body Company Benefits—Dump:

- ▶ Single 1/2", 3.5 million RBM straight frame rail provides high strength without added weight or risk of corrosion
- ▶ Factory installed lift axles with many customizable chassis packaging options
- ▶ Available in-cab battery box provides increased chassis packaging flexibility

INTERNATIONAL TRUCK SPECIALTY CENTERS

Your quick, efficient and cost-effective upfitting solution. Count on:

- ▶ Quality modifications covered under manufacturer's warranty
- ▶ Upfit process supervised by International engineers to ensure factory production-level quality
- ▶ Expertise to identify and resolve problems quickly
- ▶ A quick and efficient process ensured by optimized delivery cycle times and comprehensive factory support



DIAMOND PARTNER

**LINKING TEMS WITH DEALERS TO
STREAMLINE INSTALLATIONS AND
ENHANCE CUSTOMER UPTIME**

The Diamond Partner Program creates a new conduit between International Truck, our dealers and TEMs by providing industry-leading body-builder support materials and services. Through the program, it's now easier than ever for TEMs to mount their equipment faster, with a higher build quality and lower costs. In addition, the program facilitates joint marketing opportunities that can help increase awareness of the dealer and TEM partners.



Make complicated applications safer, more seamless and easier-to-use.

The International® Truck electrical system is a multiplexed, Diamond Logic® capable system that is considered the most advanced in the industry—and for good reason.

Diamond Logic streamlines chassis and body equipment integration and allows customers to choose from nearly 200 pre-programmed tasks. Customers can also develop their own with the help of a technician (over 260 International technicians are certified Level 3 – the highest certification) or completely on their own using Diamond Logic Builder software. The result is more consistent integrations, improved performance, increased equipment protection and crew safety.

Safety First

Diamond Logic opens up a world possibilities when it comes to safety.

- ▶ **Safety for the Driver:** Various functions including pre-trip inspections, interlocks, auto work lights, and equipment status lights can be programmed to help ensure driver safety and assist in protecting your vehicle
- ▶ **Safety on the Jobsite:** Interlocks for boom hydraulics, outriggers and PTO can increase the safety of all those nearby
- ▶ **Protecting Your Equipment:** Diamond Logic capabilities like an auto-locking and unlocking diff-lock, help mitigate human errors that can sometimes damage your equipment

THE DIAMOND LOGIC® ELECTRICAL SYSTEM.

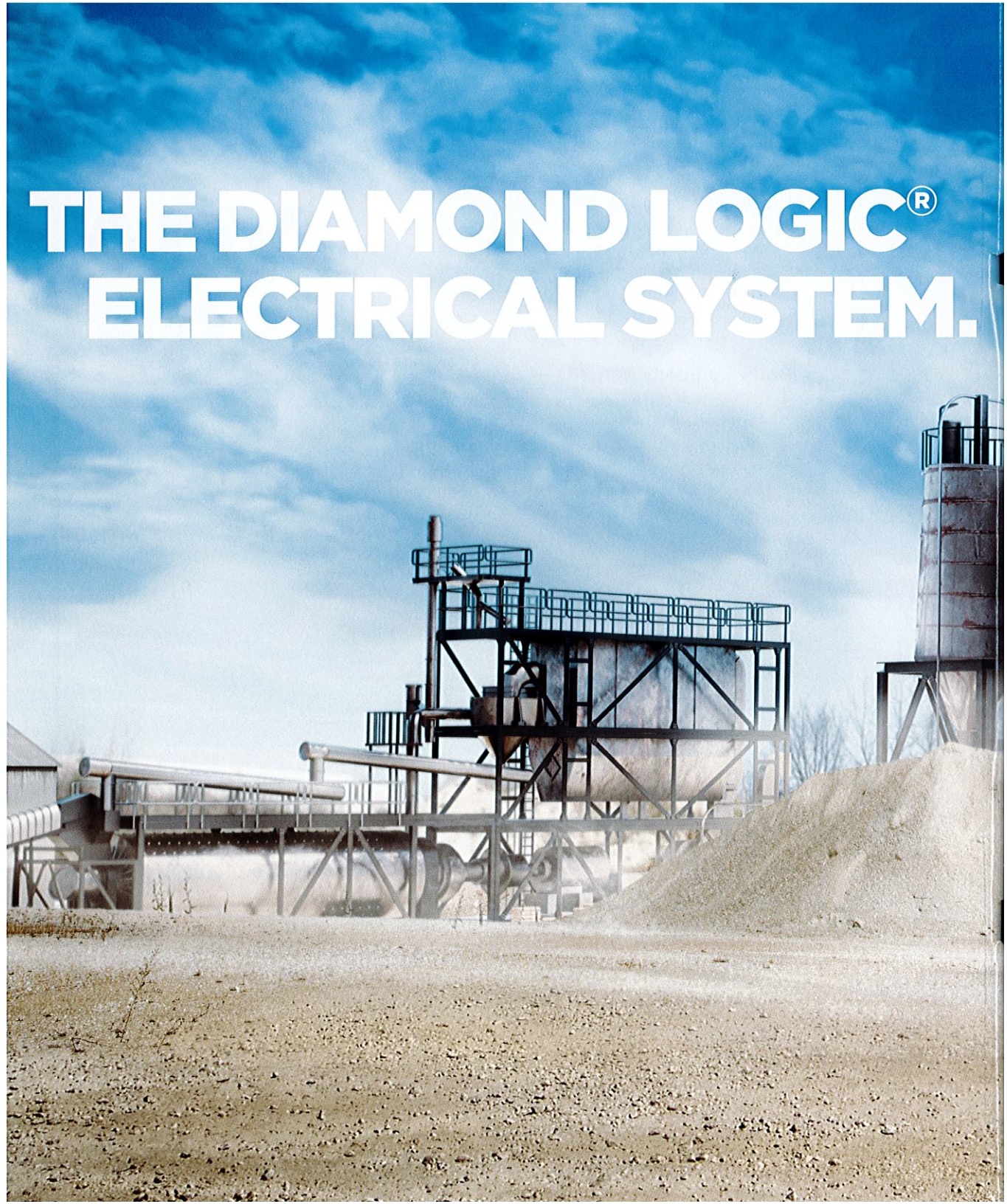



DIAMOND LOGIC BUILDER

Have a specific application requirement? International can train and certify your technicians on Diamond Logic Builder so you can write your own custom logic as you go.





**WORK HARD.
REST EASY.**

Trim Level Features/Availability

Nothing feels better after a hard day's work than a solid night's rest. The optional HX® Series sleeper cab provides drivers with a comfortable and spacious home where they can kick back, relax, and catch some z's. Because when dawn breaks, they need to be ready to get back to work — just like always.

HX SERIES SLEEPER CAB FEATURES

- ▶ Control panel located at head of bunk for blower speed, temperature controls, winter/summer selector switch, roof light switch, radio volume and balance controls, 12-volt power source
- ▶ Lift-up bunk with latch and lighting
- ▶ Available windshield curtain for privacy
- ▶ Available inner spring mattress for lower bunk
- ▶ Available insulated sleeper compartment curtain
- ▶ Two exterior lockers for access to luggage within the sleeper

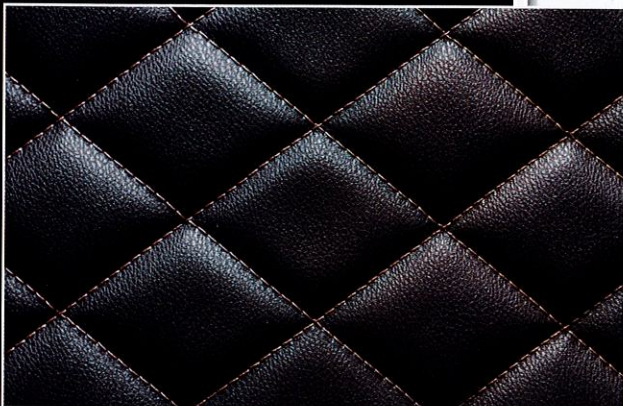

SLEEPER FEATURES

12 Volt Power Supply

Trim Panels

Headliner

Sleeper Windows

Windshield Curtain

Sleeper Control Panel

Microwave Accommodation

TV Accommodation

DIAMOND ELITE

Standard

Easy To Clean Soft Vinyl Trim With Satin Mahogany Inserts

Soft Vinyl

Standard

Optional

Standard

Optional

Optional

56" Low Roof Sleeper Features

Overhead Storage

Two Airline Style Cabinets Standard, with an Option for Two Additional

56" Hi-Rise Sleeper Features

Overhead Storage

Two Compartments with Netting or Doors

Rear Wall Storage

Optional

73" Hi-Rise Sleeper Features

Overhead Storage

Optional Two or Four Compartments with Nets or Optional Doors

Rear Wall Storage

Optional

Driver Side Wardrobe

Standard, Optional Doors

Passenger Side Cabinets

Utility Cabinet, Lower Right Wardrobe Tower Cabinet, Dresser Cabinet, Refrigerator Storage With or Without Doors



A26

INTERNATIONAL® A26

A POWERFUL AND EFFICIENT WORKHORSE READY TO TAKE ON ANY AND ALL JOBS.

Over 6,000 vocational International® A26 engines have been built in our Huntsville, Alabama engine assembly plant powering everything from emergency vehicles, mixers, overhead applications and more. The engine has proven itself in all types of extreme weather including the desert of New Mexico, the mountains of Colorado and the frigid temperatures of Quebec. For those seeking smooth, quiet, reliable power, look no further than the International A26.

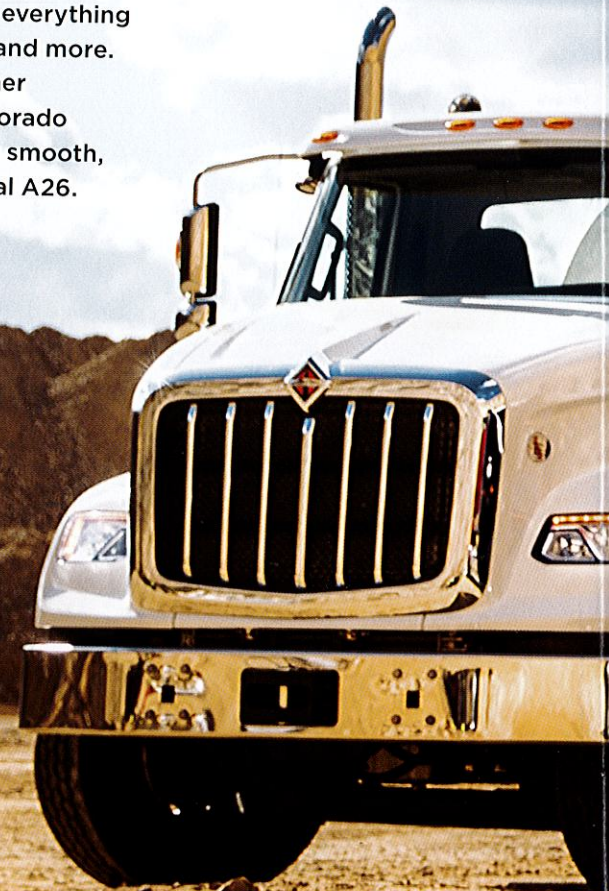
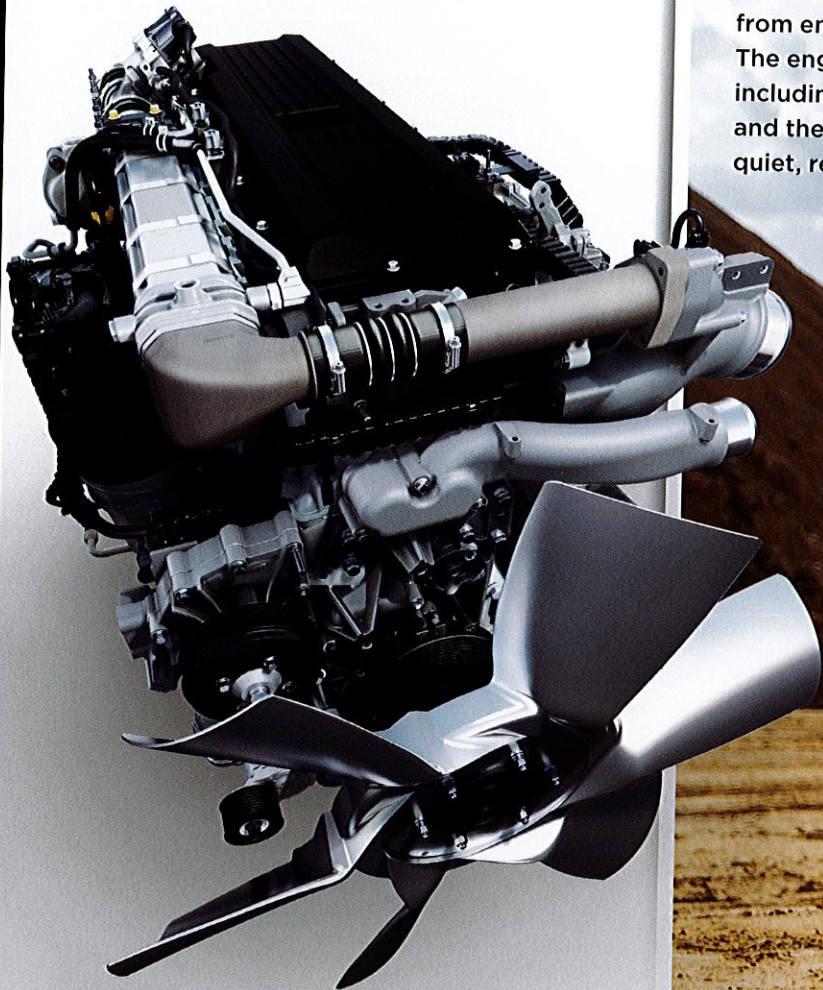

HX
INTERNATIONAL





THE ONLY OPINION THAT MATTERS: YOURS.

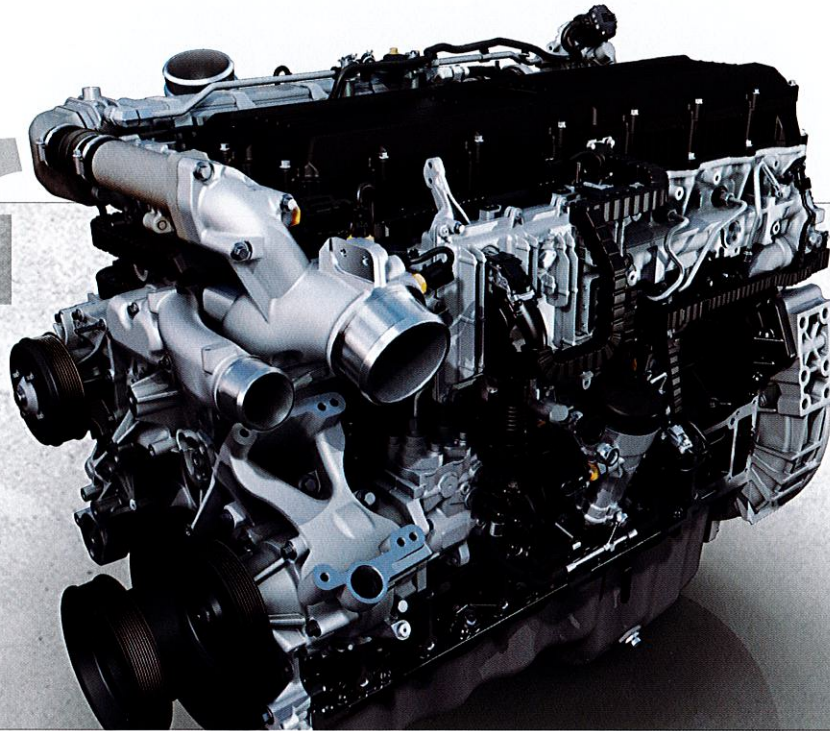

**“WE’VE HAD ZERO DOWNTIME
WITH THESE TRUCKS.”**

STEVE SPERBECK,
GENERAL MANAGER, ERL INTERMODAL

**“THE A26 HAS PLENTY OF POWER TO PULL A BULK TRAILER OF CEMENT
POWDER 650 MILES EVERY DAY, FIVE DAYS A WEEK. EVERYWHERE WE GO,
WE RUN 80,000 POUNDS. THERE’S A LOT OF HILLS AND STOP-AND-START
DRIVING, AND IT PULLS GREAT EVEN WHEN I’M FULLY LOADED.”**

DAVID “FUZZY” STAFFORD

WEIGHT



**LIGHTEST ENGINE OVER
12L AT 2,299 LBS.**

INCREASED PAYLOAD CAPACITY AND FUEL ECONOMY

NOISE



**QUIETEST ENGINE
HIGHER DRIVER SATISFACTION
AND DRIVER RETENTION**

UPTIME



**EASE OF SERVICE
LEADS TO UPTIME**

OVER THE AIR (OTA) PROGRAMMING

Update to the latest engine calibration

UPPER VALVE COVER

Only the upper valve cover is removed to adjust valve lash

WIRE HARNESSSES

Foam encapsulated for abrasion resistance
Molded in brackets are mounted with bolts for consistent installation

CARTRIDGE STYLE FUEL AND OIL FILTERS

Ease of service

HAND PRIMER FUEL PUMP

Easy access
2.5 times larger for easy use

MASS AIR FLOW (MAF) SENSOR

Located in the fresh air inlet, it does not require cleaning

HIGH TEMPERATURE FASTENERS

A permanent coating on fasteners for the exhaust manifolds, turbocharger, and heat shields is to prevent seizing

The International® A26 has shown it's more than up to the task since its introduction in 2016. At 2,299 lbs., it's the lightest engine you can get over 12-liters which allows for an increased payload capacity and better fuel economy. It's also the quietest engine in its class resulting in higher driver satisfaction and driver retention.

A26 COMMAND CENTER



This cross-functional team of specialists proactively monitors A26 engines around-the-clock to ensure all are running at 100%.

**A26 REPAIR VELOCITY EXCEEDS THE GOAL OF
80% OF REPAIRS IN LESS THAN 24 HOURS.**



INTERNATIONAL® A26 / HX620

The big bore International® A26 is engineered to set the standard in uptime, fuel efficiency and quiet operation. Producing up to 500 HP and 1,750 lb.-ft. of torque in the HX® Series, this 12.4L diesel includes a Variable Geometry Turbocharger (VGT) with a titanium compressor wheel for superior longevity versus aluminum designs. The A26 is also backed by the industry's best warranty and is the first engine to meet the B10 standard that requires 90% of delivered engines to travel 1,200,000 miles before a major repair.

Engine Type	Diesel, 4-Cycle
Configuration	Inline 6-Cylinder
Displacement	12.4 L (758 cu. in.)
Bore & Stroke	4.96 in. & 6.54 in. (126 mm & 166 mm)
Compression Ratio	18.5:1
Aspiration	Single Stage Variable Geometry Turbocharger, Intercooler & Aftercooler
Combustion System	Direct Injection
Engine Lubrication	42 Quarts (40 L)
Total Engine Weight (Dry)	2,299 lbs (1043 kg)
Valves	4 Valves Per Cylinder, Single Overhead Camshaft
B10 Design Life	1,200,000 mi (1,931,000 km)

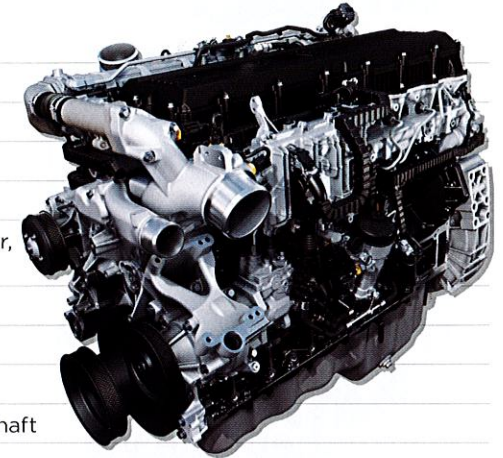

CUMMINS® X15 / HX520, HX620

The Cummins® X15 is one of the most popular heavy-duty engines in North America, for good reason. With horsepower ratings up to 605HP and 2,050 lb-ft of torque, the X15 delivers relentless performance. This power comes with plenty of efficiency, too, thanks to an XPI fuel system that gets the most out of every drop of fuel. With a standard engine brake and the power your workload demands, the X15 has what it takes to get the job done.

Engine Type	Diesel, 4-Cycle
Configuration	Inline 6-Cylinder
Displacement	14.9 L (912 cu. in.)
Bore & Stroke	5.39 in. & 6.65 in. (137mm & 169mm)
Compression Ratio	18.9:1
Aspiration	Variable Geometry Turbocharger
Combustion System	Direct Injection XPI Fuel System
Engine Lubrication	56 Quarts (53 L)
Total Engine Weight (Dry)	3,186 lbs. (1,445 kg)
Valves	4 Valves per Cylinder, Single Overhead Camshaft
B50 Design Life	1,000,000 mi (1,609,000 km)

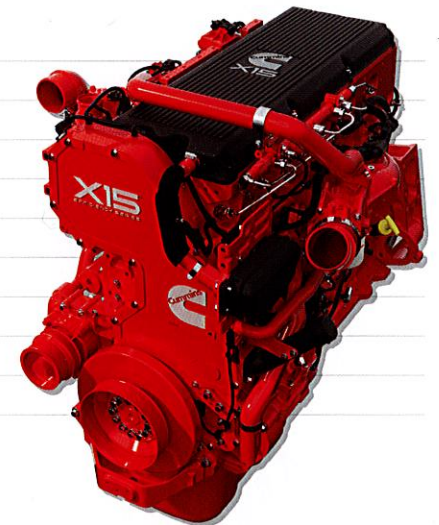

Series

Code	HP Rating	Governed Speed RPM	Torque Rating (lb-ft @ RPM)
12BDY ¹	370	2100	1350 @ 1000
12BDZ	390	2100	1450 @ 1000
12BEA	410	2100	1450 @ 1000
12BEB	430	2100	1550 @ 1000
12BEC	450	2100	1700 @ 1000
12BED	475	2100	1700 @ 1000
12BGP	500	2100	1750 @ 1000

Productivity Series

Code	HP Rating	Governed Speed RPM	Torque Rating (lb-ft @ RPM)
12ETK	430	2000	1650 @ 950
12ETL ¹	450	2000	1650 @ 950
12EVP	450	2000	1750 @ 950
12ETM	470	2000	1750 @ 950
12ETN	500	2000	1850 @ 950
12EPH ²	565	2100	1850 @ 1000
12ETS	565	2000	1850 @ 1000
12EPD	605	2000	1850 @ 1000
12EPE	605	2000	2050 @ 1000
12ETP ²	605	2100	1850 @ 1000

Performance Series

12ENZ	525	1900	1850 @ 1000
12EPB	565	1900	1850 @ 1000
12EPC	565	1900	2050 @ 1000

1 = Standard on HX620

2 = Rated for emergency vehicles only. Other X15 engines listed are not available for emergency applications.



HX[®] Series equipped with
International[®] A26 engine



HX[®] SERIES SPECIFICATIONS

HX520

120" BBC Set-Forward Front Axle Truck or Tractor

Primary Vocations:

- Heavy Haul Tractor
- Construction Dump
- Logging
- Recovery

Key Features:

- Powerful 15L Cummins[®] X15 power up to 605 HP / 2,050 lb.-ft. torque
- Excellent bridge formula chassis
- Available 0.5", 3.5 million RBM single rail frame
- Available 150,000 lb. Tow Pin
- Available dual external air cleaners for HD filtration
- BA = 29.9"

HX620

119" BBC Set-Back Front Axle Truck or Tractor

Primary Vocations:

- Heavy Haul Tractor
- Construction Dump
- Platform Stake/Crane

Key Features:

- International[®] A26 engine up to 500 HP / 1,750 lb.-ft. torque
- Powerful 15L Cummins[®] X15 power up to 605 HP / 2,050 lb.-ft. torque
- Available 0.5", 3.5 million RBM single rail frame
- Available 150,000 lb. Tow Pin
- Front axles up to 22K
- Tandem rear axles up to 70K and Tridems to 53K
- Available dual external air cleaners for HD filtration
- BA = 50.2"

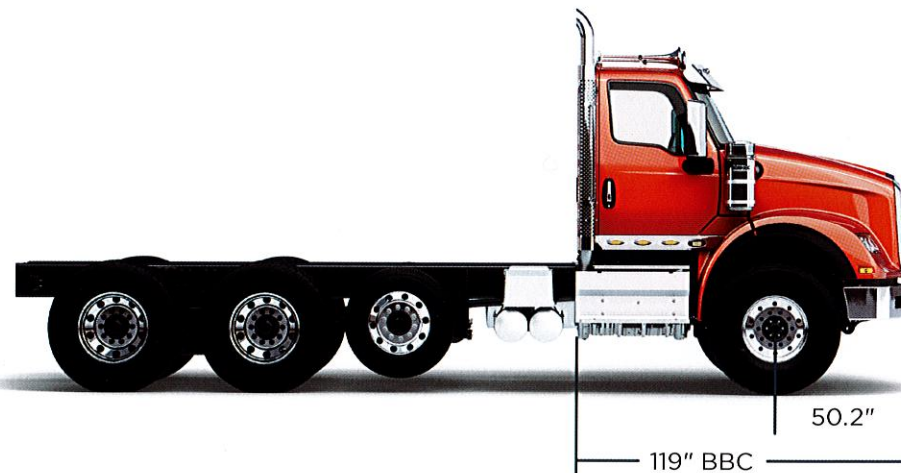
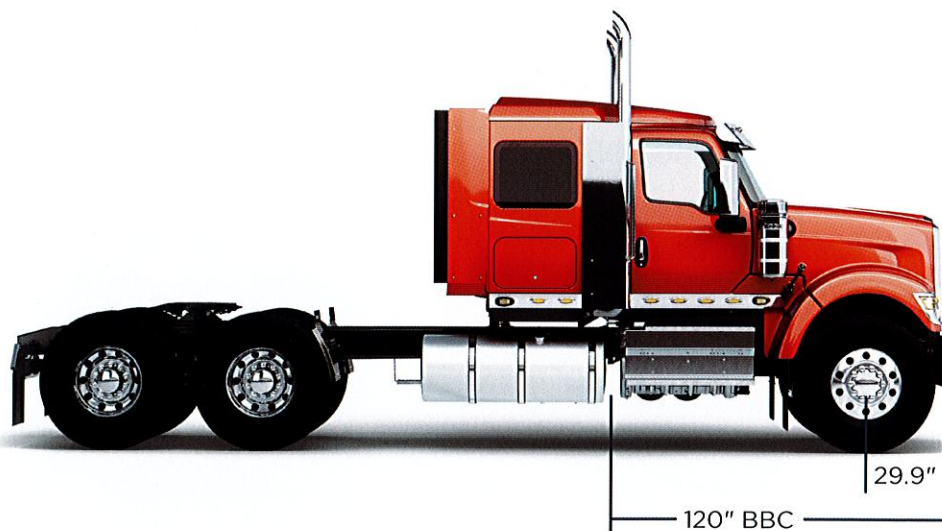

GVWR

- ▶ 52,000 – 92,000 lbs.

Models

- ▶ HX520 120" BBC, Set-Forward Front Axle Truck or Tractor
- ▶ HX620 119" BBC, Set-Back Front Axle Truck or Tractor

Axle Configurations

- ▶ 6x4
- ▶ 8x6
- ▶ 4x2 (upon request)

Cab Configurations

- ▶ Day Cab
- ▶ 56" Low and High Sleeper Cabs
- ▶ 73" High Sleeper Cab

Heat Treated Alloy Steel 120,000 PSI Frames

- ▶ Single Rail
 - 3/8": 10.25"x3.61"x0.375": 2,037,600 RBM
 - 3/8": 12.25"x3.380"x0.375": 2,521,200 RBM
 - 1/2": 12.5"x3.750"x0.5": 3,536,400 RBM
- ▶ Double Rail
 - 5/16"+ 5/16": 10.813"x3.893x0.625": 3,580,800 RBM
 - 3/8"+ 5/16": 13.030"x3.687"x0.6875": 4,854,000 RBM

Engines

- ▶ International® A26 12.4L
 - HX620
 - 370 – 500 HP*
 - 1,350 – 1,750 lb.-ft.
- ▶ Cummins® X15 15L
 - HX520 / HX620
 - 430 – 805 HP
 - 1,650 – 2050 lb.-ft.

Transmissions

- ▶ Eaton Manual: 8LL (10), 9ALL (11), 13, 18-speed
- ▶ Eaton Automated: 8LL (10), 9ALL (11), 13, and 18-speed UltraShiftPLUS®
- ▶ Allison Automatic: EVS, RDS, OFS Series

Clutch

- ▶ Standard: Hydraulic with Air Assist

Power Take Off

- ▶ Front Engine PTO (FEPTO) HX520
- ▶ Rear Engine PTO (REPTO) HX520, HX620

Front Axles (Wide Track)

- ▶ HX620
 - Dana: 16,000 – 22,000 lbs.
 - Meritor: 12,000 – 22,000 lbs.
- ▶ HX520
 - Meritor: 12,000 – 22,000 lbs.

Front Suspensions

- ▶ HX520
 - Parabolic Taper-leaf: 12,000 – 20,000 lbs.
- ▶ HX620
 - Multi-leaf: 14,000 – 23,000 lbs.
 - Parabolic Taper-leaf: 13,200 – 22,000 lbs.
 - Slipper-Type: 20,000 – 24,000 lbs.

Rear Axles

- ▶ Tandem Rear Axles
 - Dana: 46,000 – 52,000 lbs. Single and Two Speed
 - Meritor: 40,000 – 70,000 lbs. Single and Double Reduction
- ▶ Tridem Rear Axles
 - Meritor: 53,000 – 69,000lbs.

Rear Suspensions

- ▶ Spring Suspensions
 - Chalmers: 40,000 – 52,000 lbs.
 - Hendrickson HAULMAAX EX: 40,000 – 52,000 lbs
 - Hendrickson R, RT: 40,000 – 80,000 lbs.
- ▶ Air Suspensions
 - Hendrickson HAS: 40,000 – 46,000 lbs. 55" and 60" spacing
 - Hendrickson PRIMAAX EX: 46,000 – 52,000 lbs. 55", 60", 72" spacing
 - Hendrickson PAX Tridem: 69,000 lbs.



OnCommand[®] Connection



Transmit Truck Data



Diagnose Faults and Identify Severity



Inform Fleet Managers



Increase Uptime and Lower Repair Costs

OnCommand[®] Connection turns raw telematics data into actionable intelligence for all vocational truck fleets, regardless of size. Our flagship product is Advanced Remote Diagnostics, a software solution with tools designed to keep owners and fleet managers informed on the health of their vehicles so that they can address issues quickly and efficiently and maximize vehicle uptime.

SERVICE	Advanced Preventive Maintenance	Fleet Health Monitoring
FEATURE	Data-driven, VIN-level recommendations	Weekly reports on vehicles most at risk of roadside failure
BENEFIT	Maintenance cost savings through more efficient planning and fewer premature oil changes	Fewer breakdown events

Our tools include:

- An online dashboard with real-time vehicle mapping, so you always know the exact location of your vehicles
- Comprehensive vehicle health reports for each connected vehicle
- Reports that detail diagnostic trouble codes (DTCs), including severity ratings for vehicles that need immediate service, and those that can wait for their next scheduled maintenance

- Fault Code Action Plans that translate engine light indicators into simple terms for maintenance and service managers, describing the issue, parts and services needed, and more
- Driver behavior data including harsh acceleration and braking, as well as excessive idle time
- Customizable reporting delivered to your email inbox, including alerts that can be set up based on vehicle location and fault code severity

It's solutions like these that have translated into customers seeing up to 80 percent reductions in vehicle faults requiring a tow, and up to 30 percent reductions in unplanned repair and maintenance costs.

INTERNATIONAL® 360

International® 360 Services

International® 360 is a groundbreaking service communications and fleet management platform that delivers seamless and transparent communications with the International® service network. This advanced tool features a comprehensive, easy-to-use interface that supports fleets of all makes.

- ▶ **Seamless communications with dealers:** Provides a direct channel of communication to dealers and delivers updates however you need them – via email, through the International 360 portal, or into your existing fleet management systems.
- ▶ **Transparent visibility to repair status:** Keeps you updated on the location, repair status, and estimated time of completion for your assets.
- ▶ **Complete data integration:** Vehicle specs, service history, open campaigns, parts catalogs, even remote health data through telematics integrations powered by OnCommand® Connection and connected with 24+ Telematics Service Providers.
- ▶ **Easy to use:** Simple, intuitive design. Online service initiation, communication and electronic estimate approvals help expedite the service process. Integration with our dealer parts inventory system helps you find the fit-right parts fast.

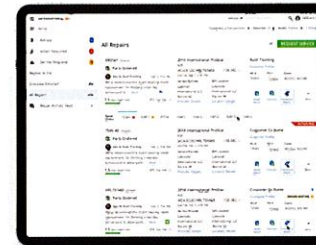

Fleet Managers



Dealers and Service Centers

INTERNATIONAL
360



Connected Fleet Providers



All-Makes Fleet Assets



We understand making money means keeping your vehicles on the road. **That's why uptime is so important to us.** Dependable equipment spec'd for your needs or requirements is just the beginning. We also focus on fuel economy, preventive maintenance, optimized service intervals and more to make sure the low cost of ownership of our vehicles helps keep you in the black.



DIAMOND EDGE[®] CERTIFIED DEALERS



A select network of International dealers with service facilities that have passed rigorous certification guidelines to provide you with faster turnarounds, immediate parts availability and a higher level of servicing expertise



**OVER
700**
INTERNATIONAL®
DEALER LOCATIONS

**OVER
350**
LOVE'S
LOCATIONS

+ **=**

**OVER
1,050**
TOTAL SERVICE
LOCATIONS

Our partnership with Love's and Speedco adds 350+ additional locations for quick, conveniently-located access to light mechanical and select warranty work.



**OWNERSHIP
SUPPORT**

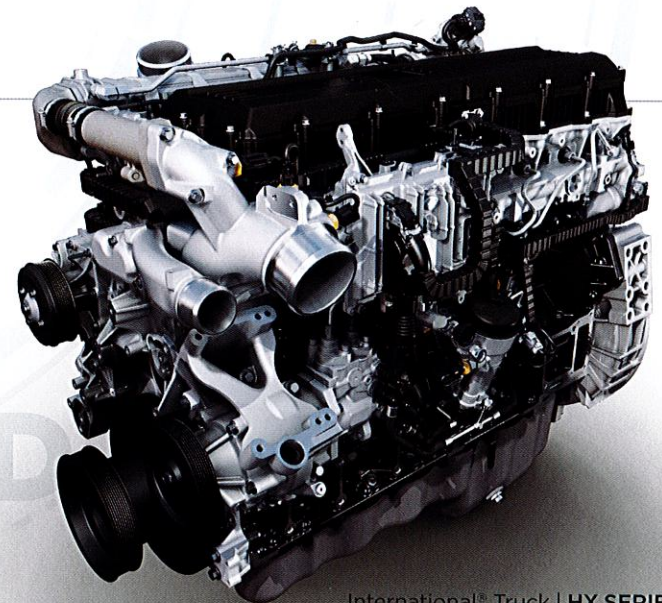
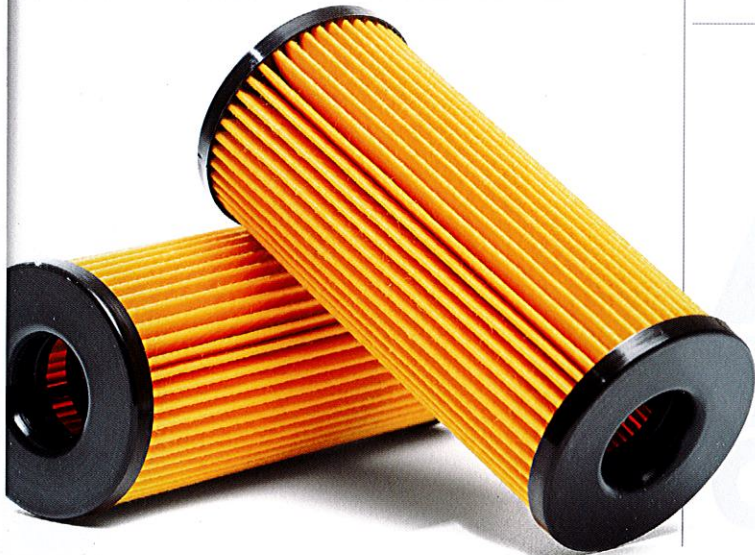



Note: The information and conclusions contained herein are believed to be correct at time of publication, but do not necessarily apply to similar vehicles with different specifications or with production dates after the production of this publication. Vehicles with different specifications or later dates of production may yield different results. Vehicle specifications are subject to change without notice. TAD20004 11/2020 ©2020 NAVISTAR Inc. All rights reserved. All marks are trademarks of their respective owners.