

BID SUBMITTAL FORM
Alabama County Joint Bid Program
Heavy Equipment – Bid Item: Heavy Duty Motor Grader - Option B

Company Name: THOMPSON TRACTOR COMPANY

Address: P.O. BOX 10367

BIRMINGHAM, AL 35202-0367

Bid Submitted by: JAY SMITH
(Name of company representative)

Title: SALES OPERATIONS MANAGER E-mail address: JAYSMITH@THOMPSONTRACTOR.COM

Phone: (205) 849-4242 Fax: _____

By submitting this bid, we agree:

Initials

The equipment model number identified below meets the bid specs for this bid item

JAS

That the bid price will be honored for all counties for the period from January 1, 2023 to December 31, 2023.

JAS

The equipment will be delivered at the bid price to all counties participating in the joint bid program.

JAS

The company acknowledges the freight preparation and delivery price is to be included in the total bid price for the standard machine.

JAS

The company representative listed above will be the contact person for purchasing this bid item under the joint bid program.

JAS

The bid is accompanied by a current catalog or model specification document for the model number identified below.

JAS

The bid is accompanied by a copy of the manufacturer's standard warranty as required in the bid specifications.

JAS

The bid includes the e-verify documentation required by Alabama law.

JAS

If awarded the bid, a performance bond will be provided upon request.

JAS

The bid documents include the **Manufacturer's Suggested Retail Price Sheet (MSRP) for the Standard Machine.**

JAS

Total Bid Price for Standard Machine: \$ 336,400
(Total Bid Price for Standard Machine Includes Freight Preparation, Delivery and Standard Warranty Costs) *

Freight Preparation and Delivery: \$ 9,794
(Included in Standard Machine Bid Price)

Manufacturer's Suggested Retail Price for Standard Machine: \$ 518,422

Equipment Model #: CATERPILLAR 140 (STEERING WHEEL)

Description: MOTOR GRADER

Signature of company representative submitting bid: 

Title: SALES OPERATIONS MANAGER

*NOTE: Award will be made based on the total cost of the **Standard Machine**. The total cost of the standard machine is to include the freight preparation, delivery and standard warranty cost. Freight preparation, delivery will be excluded from the total bid price of the standard machine in determining the percentage discount for any available options.

BID SUBMITTAL FORM: OPTION COST SHEET

By submitting this bid, we agree:

To offer any available options at the percent difference between the Manufacturer's Suggested Retail Price Sheet and the actual bid price on the Standard Machine*

RAE

The bid documents include the **Manufacturer's Suggested Retail Price Sheet (MSRP)** for the Standard Machine

RAE

Equipment Model #: CATERPILLAR 140 (STEERING WHEEL)

Description: MOTOR GRADERS

Signature of company representative submitting bid: _____

Jay Smith

Title: SALES OPERATIONS MANAGER

***NOTE:** The percent difference between the **Manufacturer's Suggested Retail Price Sheet (MSRP)** for the standard machine as specified by these **Bid Specifications** and the actual price bid by the vendor will be calculated to determine the percentage discount to be applied to any available options. The bid price of the freight preparation, delivery cost shall be excluded in determining the percentage discount to be applied to available options. Any individual county may choose to add any available option to the standard machine at the percentage discount at the time of purchase.

**BID SPECIFICATIONS
FOR
HEAVY DUTY MOTOR GRADER – OPTION B**

GENERAL

These specifications shall be construed as the minimum acceptable standards for a heavy-duty motor grader. Should the manufacturer's current published data or specifications exceed these standards, the manufacturer's standards shall be considered minimum and shall be furnished. All integral parts not specifically mentioned in the scope of these specifications that are necessary to provide a complete working unit shall be furnished. Additionally, the machine offered for bid shall include all standard manufacturer's equipment. The motor graders must be a new current production model and shall meet all EPA and other applicable standards at the time of manufacture.

The use of specific names or numbers in the specifications is not intended to restrict the bidder or any seller or manufacturer, but is intended solely for the purpose of indicating the type, size, and quality of equipment considered best adapted to the uses of counties participating in this joint bid.

BID SUBMITTAL FORM

Each bidder must submit his or her bid on the Bid Submittal Form included in the invitation to bid package. All written warranties to be submitted shall be attached to the Bid Submittal Form.

BID PRICE

The price bid shall include all destination charges, delivery charges, title fees, rebates and all other applicable costs and refunds.

MANUALS

Each unit shall be provided with one (1) copy of the operator's manual, one (1) copy of the repair manual and one (1) copy of the current parts manual. Units will not be accepted for delivery until the manuals as outlined above are received by the purchaser.

REPLACEMENT PARTS AVAILABILITY

Parts must be available for 5 years or 7,500 hours of use for the piece of equipment bid. If replacement parts are not delivered within three (3) working days of an order being placed, the bidder will deliver an equivalent machine for the County to use at no cost to the County until such time as the parts are delivered to the County so it can affect repairs to its machine.

WARRANTY

Bidders shall submit a copy of the manufacturer's standard warranty. Warranty shall include service response time of a maximum of 36 hours within notification by county.

Yes No
Page # _____
or
Attachment

ENGINE

Engine shall be a turbo-charged, direct injection, four-stroke, **6-cylinder** diesel engine and shall be electronically controlled for more efficient fuel injection and fuel burn.

Engine Shall be designed and manufactured by the machine manufacturer.

Yes No
Page # 5, 4

Engine displacement shall not be less than **567 cu. in.** and shall develop, as standard, a rated variable net power of at least **177 -250 HP.**

Yes No
Page # 4

Engine shall be isolation/resilient mounted to minimize sound and vibration and shall meet currently required EPA emission regulations for manufacturer.

Yes No
Page # 18, 19

Engine compartment enclosure doors shall be lockable without the use of external locks and accessible from the ground. All daily service points shall be accessible from ground level and grouped together.

Yes No
Page # 14

Engine will increase its low idle to **1,000 rpm** when the battery voltage is below **24.5 volts** for more than **5 minutes** to ensure adequate system voltage and battery reliability.

Yes No
Page # BID spec p.1

STARTING SYSTEM

Shall be equipped with a **24-volt** electrical system. **115-amp** alternator.

Yes No
Page # BID spec p.1

TRANSMISSION-8 Forward Speeds and 6 Reverse Speeds

Shall be designed and built by the machine manufacturer and shall be a direct drive, powershift, counter-shaft type transmission.

Yes No
Page # BID spec p.1

Shall be equipped with built-in self-diagnostic capability

Yes No
Page # 17

A controlled throttle shifting system shall be standard to smooth directional gear changes without use of the inching pedal.

Yes No
Page # 2

Final drive shall be a planetary design.

Yes No
Page # BID spec p.1

Machine shall be equipped with an electronic inching pedal for improved modulation and machine control, and with electronic over-speed protection to protect the engine and transmission from over speeding.

Yes No
Page # BID SPEC P.1

Also, to be equipped with transmission guard.

Yes No
Page # BID SPEC P.1

TANDEM

Machine to be equipped with differential lock/unlock electro-hydraulically controlled with a multi-disc design.

Yes No
Page # BID SPEC P.1

Tandems shall be capable of oscillating **15 degrees** front up and **22 degrees** Rear up, with full machine articulation and having no interference between tandem wheel and machine structure

Yes No
Page # BID SPEC P.2

CONTROLS AND HYDRAULICS

Conventional lever style controls

Yes No
Page # BID SPEC P.1

Hydraulics system shall be a closed center, load sensing type, with a variable Displacement, axial piston-type pump.

Yes No
Page # BID SPEC P.1

Implement valves shall be electro-hydraulic, designed and built by the machine manufacturer.

Yes No
Page # BID SPEC P.1

Lock valves shall be integrated into the main implement valve to prevent cylinder drift.

Yes No
Page # BID SPEC P.1

BLADES

Machine shall be equipped with **14 ft. long, 25 in** high and no less than **7/8** in thick moldboard with hydraulic side shift and tip control.

Yes No
Page # 140 PRICE PAGE

Blade shall also include reversible overlay end bits.

Yes No
Page # 140 PRICE PAGE

All blade functions shall be hydraulically or electronically actuated.

Yes No
Page # BID SPEC P.1

USE	REF NO.	LANE 2 / 3 MANDATORY	Ship Weight lbs	List Price At Factory
-----	---------	----------------------	-----------------	-----------------------

LANE SELECTION

OP-9002	LANE 2 ORDER	0
	Only for dealers enrolled in the Base Orders Management (BOM) program.	
OP-9003	LANE 3 ORDER	0

PERFORMANCE PACKAGES

MOLDBOARDS

L	320-9924	MOLDBOARD, 12' BASIC	0
		FOR USE IN LANE 3 ONLY	
		INCLUDES:	
		- Moldboard 12' x 24" x 7/8" (3658mm x 610mm x 22mm)	
		- Curved Cutting Edge, 6" X 5/8" (152mm x 16mm)	
		- End Bits, Standard, Without Overlay	
L	526-7045	MOLDBOARD, 14' BASIC	0
		INCLUDES:	
		- Moldboard 14' x 24" x 7/8" (4267mm x 610mm x 22mm)	
		- Curved Cutting Edge, 8" x 3/4" (203mm x 19mm)	
		- End Bits, Standard, Without Overlay	
L	439-9110	MOLDBOARD, 14' PLUS	0
		INCLUDES:	
		- Moldboard 14' x 27" x 1" (4267mm x 686mm x 25mm)	
		- Curved Cutting Edge, 8" x 3/4" (203mm x 19mm)	
		- End Bits, Standard, With Overlay	

REAR WORK TOOLS

P	523-8156	NO HITCH	0
		Provides a plate that bolts to the bumper that allows for attachment points for ripper or auxiliary hoses.	
P	507-7694	HITCH, TOWING	0
		Retrieval hitch. Does not include pin.	
P	515-4649	RIPPER-SCARIFIER, REAR	0
		Hydraulic, rear mounted ripper with three straight ripper shanks. Can accommodate two additional ripper shanks and nine scarifier teeth which must be ordered separately.	
		RECOMMENDED FOR USE WITH: 336-1559 PUSH PLATE, COUNTERWEIGHT	
L	558-2400	RIPPER, SNOW WING READY	0
		FOR USE IN LANE 3 ONLY	
		Hydraulic, rear mounted ripper with three straight ripper shanks. Includes the mount for the Caterpillar Mastless Snow Wing on the right side of the ripper backplate.	
		Can accommodate two additional ripper shanks, nine scarifier teeth, and the Caterpillar Mastless Snow wing which must be ordered separately.	

Blade lift accumulators shall be available, to reduce vertical impact damage.

Yes No
Page # BID SPEC P. 3

DRAWBAR AND CIRCLE

Circle shall be a single piece, rolled ring forging with raised wearing surface top and bottom

Yes No
Page # BID SPEC P. 2

Must be equipped with replaceable wear strips between circle and support shoes.

Yes No
Page # BID SPEC P. 2

Rear drawbar shall be equipped with slip clutch designed to protect the circle, drawbar, and moldboard from shock when end of blade encounters, hidden objects.

Yes No
Page # BID SPEC P. 3

Drawbar shall feature welded protective wear plates to prevent lift group contact with the primary drawbar structure.

Yes No
Page # BID SPEC P. 3

The circle shall be steel construction with 6 replaceable wear shoes.

Yes No
Page # BID SPEC P. 2

FRAME

Articulated type main frame.

Yes No
Page # BID SPEC P. 1

Articulation joint shall have mechanical locking device to prevent frame articulation while servicing or transporting machine.

Yes No
Page # BID SPEC P. 3

Shall be that of a flanged box section type frame that runs from the front bolster to the articulation joints.

Yes No
Page # BID SPEC P. 1

STEERING WHEEL

Fully hydraulic, 2-cylinder steering system, with front steering wheel angle not less than 50° left or right.

Yes No
Page # BID SPEC P. 1

TIRES

All six wheels shall be **10 in by 24 in size** multi-piece tire rims and shall provide mounting for **14.00 R24** tires.

Yes No
Page # 140 *TIRES*
SELECTION
→

Tires shall be Goodyear, Bridgestone/Firestone, or Michelin only, **14.00 x R24** 12PR Bias Tires.

Yes No
Page # 140 *TIRES*
SELECTION
→

BRAKES

Service brakes shall be multi-disc, oil-cooled and completely sealed.

Yes No
Page # 212 *SPEC P.1*

OIL ANALYSIS

To be included at no cost of the duration of the warranty period selected at intervals recommended by the manufacturer's warranty and maintenance schedule.

Yes No
Page #

WEIGHT (STANDARD OPERATING)

Base machine weight shall not be less than **42,325 lbs.** Weight shall include standard machine configuration, lubricants, coolants, full fuel tank, push block, transmission guard, rear ripper/scarifier, 14.0 R24 tires on multi-piece rims, and operator of **200lbs** This is factory specified operating weight only. No additional weights may be added for purpose of meeting these specifications.

Yes No
Page # 19, 1

USE	REF NO.	LANE 2 / 3 MANDATORY	Ship Weight lbs	List Price At Factory
-----	---------	----------------------	-----------------	-----------------------

TIRES, RIMS, AND WHEELS

Tires listed below include a set of six tires.
 ** To calculate tire loads with machine attachments, please reference the MG Tire Selection Pocket Guide (media #AEXQ0182), available on the Electronic Sales Library.
 All tire selections should be made with consideration for planned machine attachments (OEM and aftermarket) and their additional weight. Each tire has a maximum load rating that is not to be exceeded. The tire selection should be based on the maximum of all tire position loads on the machine. Assistance for calculating the highest tire load can be found in the Tire Load Worksheet in the back of the Caterpillar Motor Graders Tire Selection Pocket Guide. Failure to abide by the load ratings of the tires without first consulting the local tire supplier representative could result in nullification of the tire warranty.

Due to industry-wide tire availability limitations, tire brand and type cannot be guaranteed. Every effort will be made to satisfy your tire choice, but we reserve the right to change to alternate tires. If the tire brand cannot be supplied, the dealer will be contacted to propose alternative tire options. The dealer will need to respond with an alternative tire selection within 72 hours. If no response is provided by the supplier, the order will default to a comparable tire. As a consequence of a tire change the total machine price will be decreased or increased relative to the price of the new tire selection.

The information provided can be used to make a tire selection based on the particular conditions at the site. When available, the tire manufacturer should be consulted regarding proper tire selection.

APPLICATION SPECIFIC

L	515-5399	TIRES, 14.0R24 SOIL TRACTION MP 0 Tire group received will be one of the tire groups listed below: - Bridgestone VKT 1* on 10" x 24" multi-piece rims. - Michelin XGLA2 1* on 10" x 24" multi-piece rims. THE TIRE MANUFACTURER DOES NOT RECOMMEND THIS TIRE FOR INDIVIDUAL TIRE LOADS EXCEEDING (8045 lbs) 3650 kg.** ONLY FOR USE WITH: 515-2449 140 13A MOTOR GRADER
L	515-5400	TIRES, 17.5R25 SOIL TRACTION MP 0 Tire group received will be one of the tire groups listed below: - Bridgestone VKT 1* on 14" x 25" multi-piece rims. - Michelin XTLA 1* on 14" x 25" multi-piece rims. THE TIRE MANUFACTURER DOES NOT RECOMMEND THIS TIRE FOR INDIVIDUAL TIRE LOADS EXCEEDING (8045 lbs) 3650 kg.** ONLY FOR USE WITH: 515-2449 140 13A MOTOR GRADER

USE	REF NO.	LANE 2 / 3 MANDATORY	Ship Weight lbs	List Price At Factory
-----	---------	----------------------	-----------------	-----------------------

TIRES, RIMS, AND WHEELS (CONT.)

APPLICATION SPECIFIC (Cont.)

L	515-5404	TIRES, 14.0R24 SOIL TRACTION MP 0 Tire group received will be one of the tire groups listed below: - Bridgestone VKT 1* on 10" x 24" multi-piece rims. - Michelin XGLA2 1* on 10" x 24" multi-piece rims. THE TIRE MANUFACTURER DOES NOT RECOMMEND THIS TIRE FOR INDIVIDUAL TIRE LOADS EXCEEDING (8045 lbs) 3650 kg.** ONLY FOR USE WITH: 515-8361 140 13A AWD MOTOR GRADER		
L	515-5405	TIRES, 17.5R25 SOIL TRACTION MP 0 Tire group received will be one of the tire groups listed below: - Bridgestone VKT 1* on 14" x 25" multi-piece rims. - Michelin XTLA 1* on 14" x 25" multi-piece rims. THE TIRE MANUFACTURER DOES NOT RECOMMEND THIS TIRE FOR INDIVIDUAL TIRE LOADS EXCEEDING (8045 lbs) 3650 kg.** ONLY FOR USE WITH: 515-8361 140 13A AWD MOTOR GRADER		

SHIPPING TIRES

L	448-5577	TIRES, 14.0 SHIPPING, MP 90 FOR USE IN LANE 3 ONLY Due to the height of the shipping tires, unloading will most likely require a crane to avoid damaging the bottom of the machine. Shipping tire for use during shipment of machine only. Solid rubber band mounted on 10" x 24" multi-piece rims. Must be replaced with pneumatic tire before delivering to customer. ONLY FOR USE WITH: 515-2449 140 13A MOTOR GRADER		
L	440-3433	TIRES, 17.5 SHIPPING, MP 274 FOR USE WITH LANE 3 ONLY Due to the height of the shipping tires, unloading will most likely require a crane to avoid damaging the bottom of the machine. Shipping tire for use during shipment of machine only. Solid rubber band mounted on 14" x 25" multi-piece rims. Must be replaced with pneumatic tire before delivering to customer ONLY FOR USE WITH: 515-2449 140 13A MOTOR GRADER		
L	448-5584	TIRES, 14.0 SHIPPING, AWD, MP 69 FOR USE WITH LANE 3 ONLY Due to the height of the shipping tires, unloading will most likely require a crane to avoid damaging the bottom of the machine. Shipping tire for use during shipment of machine only. Solid rubber band mounted on 10" x 24" multi-piece rims. Must be replaced with pneumatic tire before delivering to customer. ONLY FOR USE WITH: 515-8361 140 13A AWD MOTOR GRADER		
L	440-3434	TIRES, 17.5 SHIPPING, AWD, MP 83 FOR USE WITH LANE 3 ONLY Due to the height of the shipping tires, unloading will most likely require a crane to avoid damaging the bottom of the machine. Shipping tire for use during shipment of machine only. Solid rubber band mounted on 14" x 25" multi-piece rims. Must be replaced with pneumatic tire before delivering to customer ONLY FOR USE WITH: 515-8361 140 13A AWD MOTOR GRADER		

USE	REF NO.	LANE 2 / 3 MANDATORY	Ship Weight lbs	List Price At Factory
-----	---------	----------------------	-----------------	-----------------------

TIRES, RIMS, AND WHEELS (CONT.)

MAXAM

L	578-9458	TIRES 17.5R25 MA MS202 ** MP 0 FOR USE IN LANE 3 ONLY Maxam MS202 2* on 14- x 25- multi-piece rims. THE TIRE MANUFACTURER DOES NOT RECOMMEND THIS TIRE FOR INDIVIDUAL TIRE LOADS EXCEEDING (8600 lbs) 3900kg.* ONLY FOR USE WITH: 515-2449 140 13A MOTOR GRADER		
L	578-9460	TIRES 14.00R24 MA MS202 * MP 0 FOR USE IN LANE 3 ONLY Maxam MS202 2* on 14- x 25- multi-piece rims. THE TIRE MANUFACTURER DOES NOT RECOMMEND THIS TIRE FOR INDIVIDUAL TIRE LOADS EXCEEDING (8600 lbs) 3900kg.* ONLY FOR USE WITH: 515-2449 140 13A MOTOR GRADER		
L	578-9462	TIRES 17.5R25 MA MS202 ** MP 0 FOR USE IN LANE 3 ONLY Maxam MS202 2* on 14- x 25- multi-piece rims. THE TIRE MANUFACTURER DOES NOT RECOMMEND THIS TIRE FOR INDIVIDUAL TIRE LOADS EXCEEDING (8600 lbs) 3900kg.** ONLY FOR USE WITH: 515-8361 140 13A AWD MOTOR GRADER		
L	578-9463	TIRES 14.00R24 MA MS202 * MP 0 FOR USE IN LANE 3 ONLY Maxam MS202 2* on 14- x 25- multi-piece rims. THE TIRE MANUFACTURER DOES NOT RECOMMEND THIS TIRE FOR INDIVIDUAL TIRE LOADS EXCEEDING (8600 lbs) 3900kg.** ONLY FOR USE WITH: 515-8361 140 13A AWD MOTOR GRADER		

MICHELIN

L	252-0701	TIRES, 14.0R24 MX XSNO + * G2 MP. 1,282 FOR USE IN LANE 3 ONLY Michelin XSNO 1* on 10" x 24" multi-piece rims. THE TIRE MANUFACTURER DOES NOT RECOMMEND THIS TIRE FOR INDIVIDUAL TIRE LOADS EXCEEDING (7824 lbs) 3550 kg.** ONLY FOR USE WITH: 515-2449 140 13A MOTOR GRADER		
L	252-0771	TIRES, 17.5R25 MX XTLA * L2 MP 1,371 Michelin XTLA 1* on 14" x 25" multi-piece rims. THE TIRE MANUFACTURER DOES NOT RECOMMEND THIS TIRE FOR INDIVIDUAL TIRE LOADS EXCEEDING (8045 lbs) 3650 kg.** ONLY FOR USE WITH: 515-2449 140 13A MOTOR GRADER		
L	249-7845	TIRES, 14.0R24 MX XSNO + * G2 MP. 1,261 Michelin XSNO 1* on 10" x 24" multi-piece rims. THE TIRE MANUFACTURER DOES NOT RECOMMEND THIS TIRE FOR INDIVIDUAL TIRE LOADS EXCEEDING (7824 lbs) 3550 kg.** ONLY FOR USE WITH: 515-8361 140 13A AWD MOTOR GRADER		
L	252-0679	TIRES, 14.0R24 MX XGLA2 * G2 MP 1,069 Michelin XGLA2 1* on 10" x 24" multi-piece rims. THE TIRE MANUFACTURER DOES NOT RECOMMEND THIS TIRE FOR INDIVIDUAL TIRE LOADS EXCEEDING (7824 lbs) 3550 kg.** ONLY FOR USE WITH: 515-2449 140 13A MOTOR GRADER		
L	252-0777	TIRES, 17.5R25 MX XSNO + * G2 MP. 1,093 Michelin XSNO+ 1* on 14" x 25" multi-piece rims. THE TIRE MANUFACTURER DOES NOT RECOMMEND THIS TIRE FOR INDIVIDUAL TIRE LOADS EXCEEDING (8045 lbs) 3650 kg.** ONLY FOR USE WITH: 515-2449 140 13A MOTOR GRADER		

USE	REF NO.	LANE 2 / 3 MANDATORY	Ship Weight lbs	List Price At Factory
-----	---------	----------------------	-----------------	-----------------------

TIRES, RIMS, AND WHEELS (CONT.)

MICHELIN (Cont.)

L	252-0681	TIRES,14.0R24 MX XGLA2 * G2 MP 1,048 Michelin XGLA2 1* on 10" x 24" multi-piece rims. THE TIRE MANUFACTURER DOES NOT RECOMMEND THIS TIRE FOR INDIVIDUAL TIRE LOADS EXCEEDING (7824 lbs) 3550 kg.** ONLY FOR USE WITH: 515-8361 140 13A AWD MOTOR GRADER		
L	252-0773	TIRES, 17.5R25 MX XTLA * L2 MP 268 Michelin XTLA 1* on 14" x 25" multi-piece rims. THE TIRE MANUFACTURER DOES NOT RECOMMEND THIS TIRE FOR INDIVIDUAL TIRE LOADS EXCEEDING (8045 lbs) 3650 kg.** ONLY FOR USE WITH: 515-8361 140 13A AWD MOTOR GRADER		
L	252-0779	TIRES,17.5R25 MX XSNO+ * G2 MP. 903 Michelin XSNO+ 1* on 14" x 25" multi-piece rims. THE TIRE MANUFACTURER DOES NOT RECOMMEND THIS TIRE FOR INDIVIDUAL TIRE LOADS EXCEEDING (8045 lbs) 3650 kg.** ONLY FOR USE WITH: 515-8361 140 13A AWD MOTOR GRADER		

BRIDGESTONE

L	252-0775	TIRES, 17.5R25 BS VKT * D2A MP 1,810 Bridgestone VKT 1* on 14" x 25" multi-piece rims. THE TIRE MANUFACTURER DOES NOT RECOMMEND THIS TIRE FOR INDIVIDUAL TIRE LOADS EXCEEDING (8045 lbs) 3650 kg.** ONLY FOR USE WITH: 515-2449 140 13A MOTOR GRADER		
L	249-7841	TIRES, 17.5R25 BS VKT * D2A MP 1,620 Bridgestone VKT 1* on 14" x 25" multi-piece rims. THE TIRE MANUFACTURER DOES NOT RECOMMEND THIS TIRE FOR INDIVIDUAL TIRE LOADS EXCEEDING (8045 lbs) 3650 kg.** ONLY FOR USE WITH: 515-8361 140 13A AWD MOTOR GRADER		
L	600-4199	TIRES, 550/65R25 BS VTS *L3 MP 0 Offers optimum traction and low ground pressure for fine grading applications. Bridgestone VTS 1* on 14" x 25" multi-piece rims. THE TIRE MANUFACTURER DOES NOT RECOMMEND THIS TIRE FOR INDIVIDUAL TIRE LOADS EXCEEDING (8045 lbs) 3650 kg.** ONLY FOR USE WITH: 515-8361 140 13A AWD MOTOR GRADER		

GOODYEAR

L	310-7326	TIRE, 17.5R25 GY RL2+ 6S 1*MP. 1,200 Goodyear RL2+ 6S on 14" x 25" multi-piece rims THE TIRE MANUFACTURER DOES NOT RECOMMEND THIS TIRE FOR INDIVIDUAL TIRE LOADS EXCEEDING (8045 lbs) 3650 kg.** ONLY FOR USE WITH: 515-2449 140 13A MOTOR GRADER		
---	----------	---	--	--

FLUIDS

COOLANT ANTIFREEZE

P	522-6654	COOLANT (-40C) 0 Standard engine coolant		
P	522-6655	COOLANT (-50C) 0 Engine coolant recommended for extreme low temperatures		

140	HEAVY DUTY MOTOR GRADER B	2023 Pricing
515-2449	140 MOTOR GRADER STEERING WHEEL	\$478,572
439-9110	14' PLUS MOLDBOARD BLADE, 14' X 27" X 1" INCLUDES END BITS WITH OVERLAY	\$1,915
507-7694	TOWING HITCH	\$764
522-6393	COLD WEATHER PACKAGE (ETHER STARTING AID)	\$1,060
380-6774	NON SY-KLONE PRECLEANER	\$0
559-2201	HYDRAULIC LINK BAR	\$0
522-6751	STANDARD DRAWBAR	-\$2,885
566-5529	NO GRADE CONTROL TECHNOLOGY	\$0
453-2908	MANUAL LOCK OUT	\$1,645
524-8998	BASE HYDRAULICS	\$0
526-9853	BLADE ACCUMULATORS	\$5,730
515-2231	HEAVY DUTY STARTER	\$0
562-3742	ROADING LIGHTS W/ FOLD DOWN ARM	\$2,310
522-6688	CAB PLUS	\$2,260
518-3382	AIR SUSPENSION SEAT	\$3,145
565-2320	EXTERNAL MIRRORS	\$0
519-3712	CELULAR PRODUCT LINK PLE641	\$0
558-3846	STANDARD FAN	\$0
252-0679	14.0R24 MX XGLA2 * G2 MP MICHELIN RADIAL TIRES WITH MULTI-PIECE RIMS	\$16,644
522-6654	COOLANT	\$0
0P-1939	WINDHSHIELD WASHER	\$0
0P-3978	FUEL ANTIFREEZE	\$0
386-1254	ENGLISH INSTRUCTIONS	\$0
516-2552	ENGLISH DECALS	\$0
519-3700	HALOGEN LIGHTS	\$901
501-4739	HALOGEN CAB ROOF LIGHTS	\$0
518-3017	WARNING STROBE	\$792
524-1768	REAR VISION CAMERA	\$0
518-3026	AM/FM BLUETOOTH RADIO	\$809
522-2419	TRANSMISSION GUARD	\$4,760
TOTAL BID PRICE FOR STANDARD MACHINE		\$336,400
FREIGHT PREPARATION AND DELIVERY		\$9,794
TOTAL MANUFACTURER'S SUGGESTED RETAIL PRICE FOR STANDARD MACHINE		\$518,422

140/150/160

Motor Graders

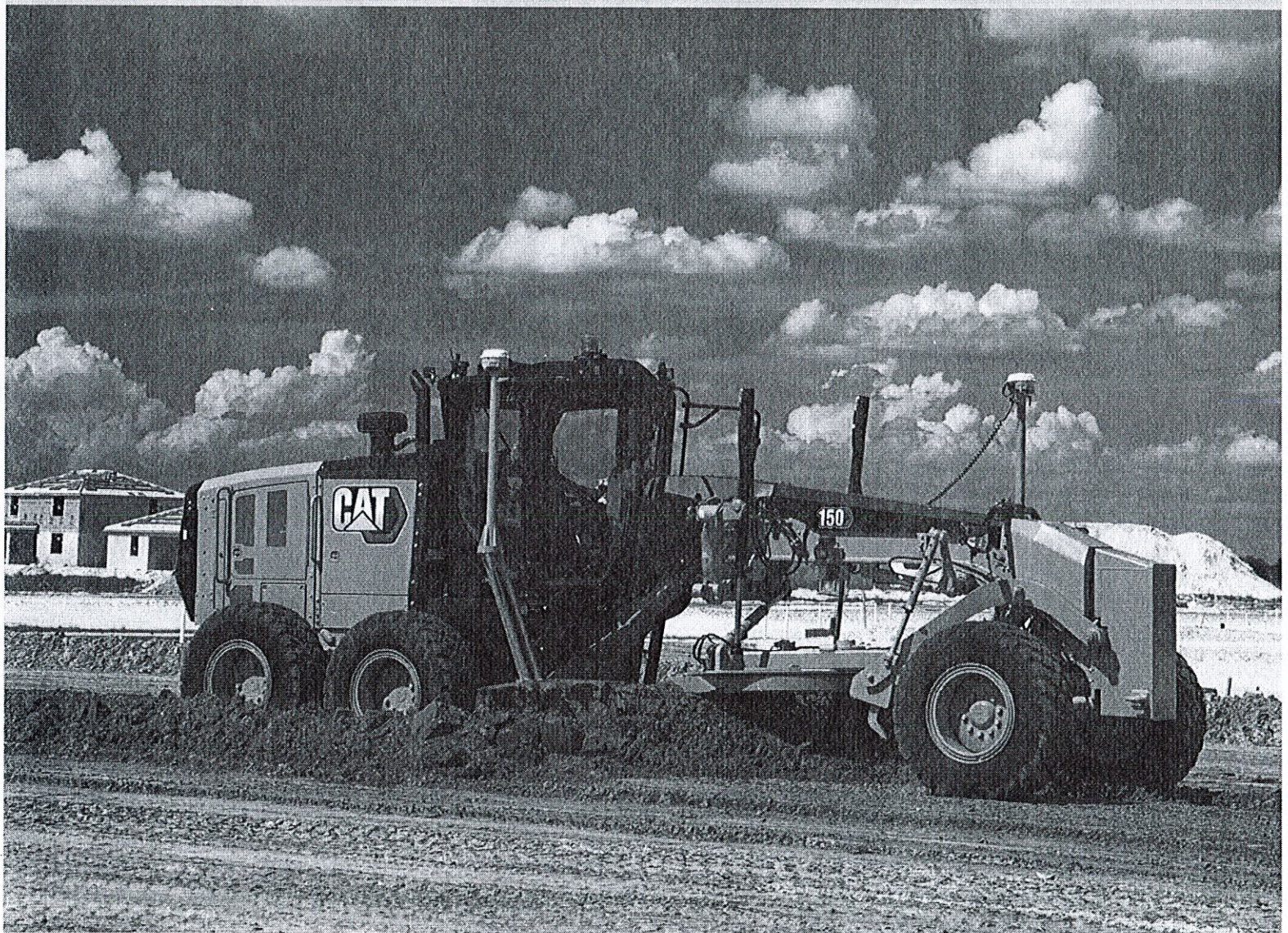

	140/140 AWD		150/150 AWD		160/160 AWD	
Engine Model	Cat® C9.3		Cat C9.3		Cat C9.3	
Base Power (1st gear) – Net	133 kW	179 hp	149 kW	200 hp	165 kW	221 hp
Base Power (1st gear) – Net (Metric)		181 hp		202 hp		224 hp
VHP Plus Range – Net	133-172 kW	179-231 hp	149-188 kW	200-252 hp	165-203 kW	221-272 hp
VHP Plus Range – Net (Metric)		181-234 hp		202-255 hp		224-276 hp
AWD Range – Net	141-188 kW	189-252 hp	156-203 kW	210-272 hp	172-219 kW	231-293 hp
AWD Range – Net (Metric)		192-255 hp		213-276 hp		234-298 hp
Moldboard – Blade Width	3.7 m	12 ft	3.7 m	12 ft	4.2 m	14 ft
Operating Weight, Typically Equipped	19 344 kg	42,647 lb	19 935 kg	43,950 lb	20 660 kg	45,547 lb
Operating Weight, Typically Equipped AWD	20 236 kg	44,614 lb	20 827 kg	45,917 lb	21 552 kg	47,514 lb

Features

Emissions Reduction

Cat emissions reduction technology is designed to be transparent to the operator and meets U.S. EPA Tier 4 Final/EU Stage V standards.

Operator Comfort

Industry leading cab and intuitive joystick controls give you unmatched comfort and visibility. New seat offers you heated/ventilated options.

Ease of Service

Drawbar-Circle-Moldboard features make it easy to maintain factory tightness for better grading results. New engine enclosure lights make service more convenient in low light.

Efficient Performance

New Economy Mode helps you save fuel – up to 10 percent.

Integrated Technologies

Cat Connect makes smart use of technology and services to help you monitor, manage and enhance job site operations.

Safety

Features like Operator Not Present monitoring, hydraulic lockout and redundant steering and braking systems help you meet your safety goals.

Contents

Operator Station.....	4
Machine and Implement Controls.....	5
Engine.....	6
Emissions Technology.....	7
Power Train.....	8
Structures and Drawbar-Circle-Moldboard....	9
Hydraulics.....	10
All Wheel Drive (AWD).....	11
Integrated Technologies.....	12
Safety.....	14
Work Tools and Attachments.....	16
Smart Machine Systems.....	17
Serviceability and Customer Support.....	17
Sustainability.....	18
Specifications.....	19
Standard Equipment.....	33
Optional Equipment.....	34
Notes.....	35

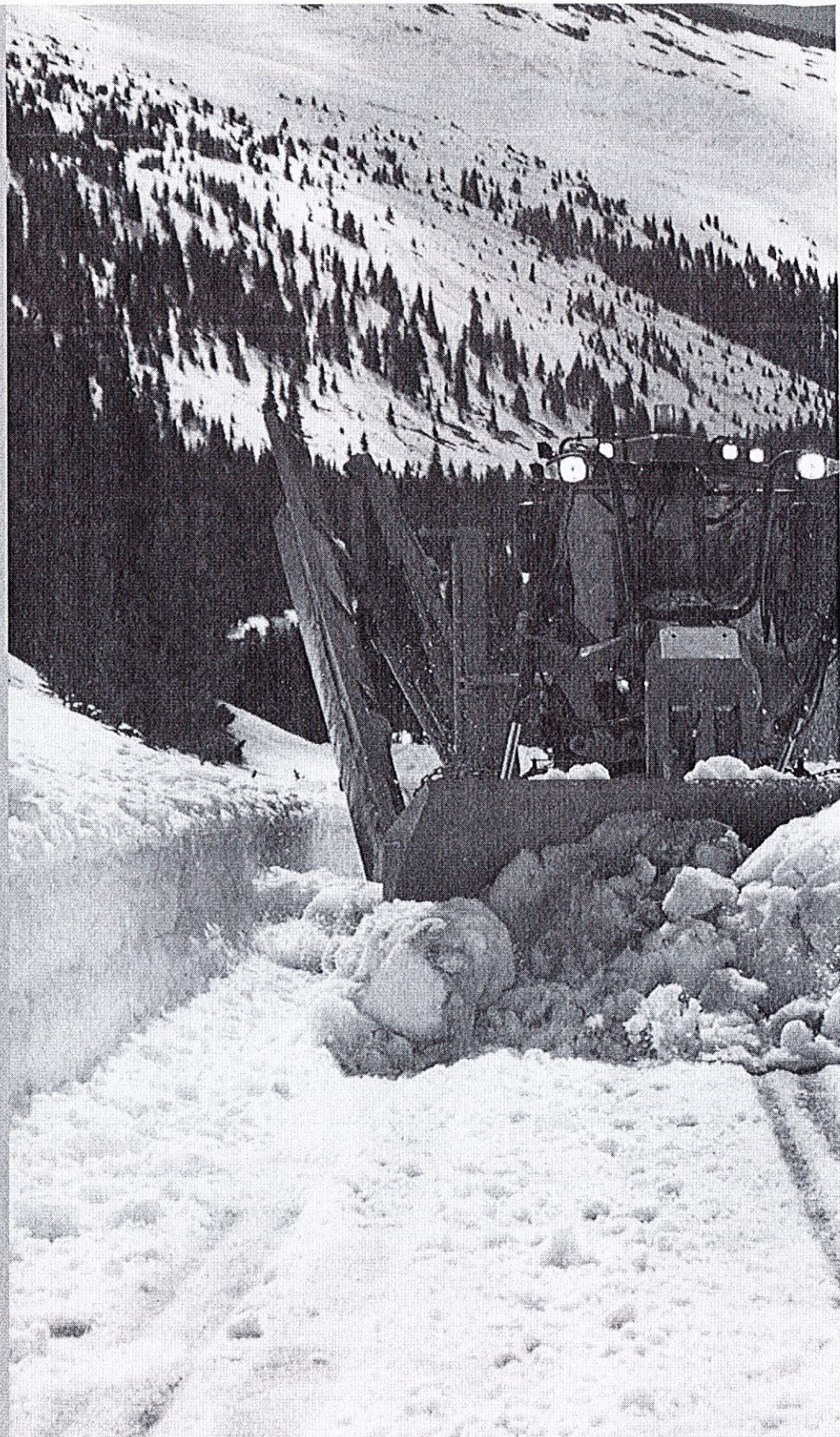



The 140/150/160 Motor Graders bring the latest emissions reduction technology to the most durable, productive and comfortable motor graders on the market. From building roads to maintaining them, motor graders are designed to help you get more work done in less time. Outstanding durability, unprecedented operator comfort and ease of service help to maximize your return on investment. The 140/150/160 Motor Graders meet U.S. EPA Tier 4 Final/EU Stage V standards.

Operator Station

Comfort, productivity, advanced technology

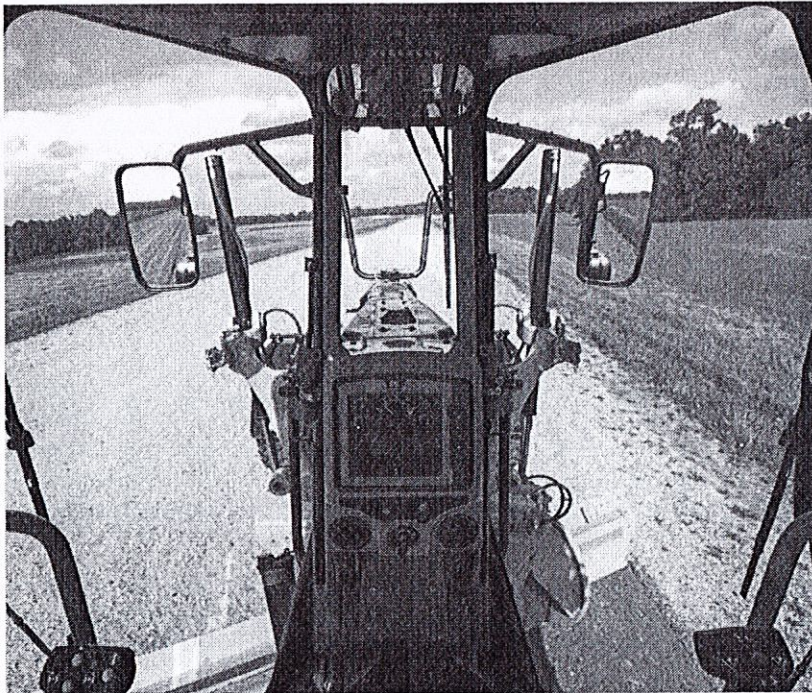

Visibility

Good visibility is key to your safety and efficiency. Angled cab doors, tapered engine enclosure and a sloped rear window make it easy to see the moldboard and tires, as well as behind the machine. An optional rear vision camera further enhances lines of sight all around the machine.

In-Dash Instrument Cluster

A redesigned message display shows machine performance and diagnostic information, including DEF tank levels. Now located in the center console, it also displays Cat Grade Control Cross Slope readings conveniently in front of the operator.

Comfort and Control

Experience the most comfortable cab in the industry. Joystick controls replace levers, so hand and arm movement is reduced by 78%, helping reduce operator fatigue for better productivity. Rocker and control switches are in easy reach.

An updated seat with softer cushions and three-position cushion tilt adds to your overall comfort. You can even upgrade to a heated or heated/ventilated seat. An optional seat belt indicator feature is also available. Control pods can be adjusted electronically, making it easy to set your ideal operating position. Multiple isolation mounts significantly reduce sound and vibration for a more relaxed work environment.

The high capacity Heating, Ventilation and Air Conditioning (HVAC) system dehumidifies and pressurizes the cab, seals out dust and helps keep windows clear. Pop-out louvers circulate fresh air. An optional deluxe radio with CD features MP3 and Bluetooth technology.

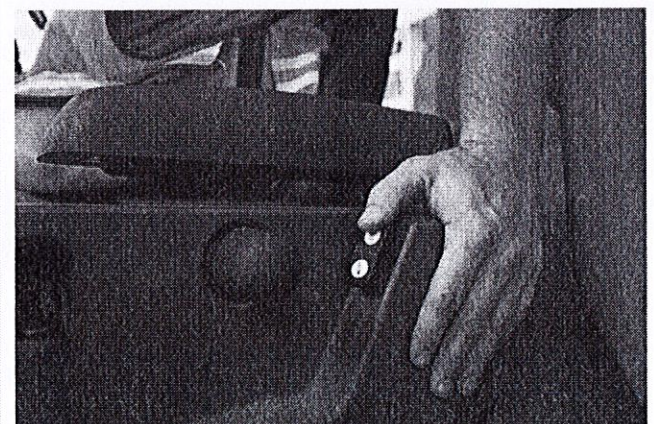
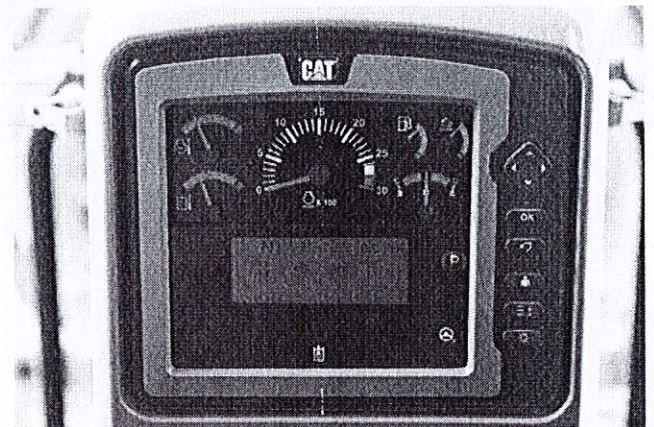

Machine and Implement Controls

Unprecedented precision and ease of operation



Two electro-hydraulic joysticks with electronically adjustable control pods help position operators for optimal comfort, visibility and productive operation.

Joystick Functions

The left joystick controls machine direction, steering, articulation, return-to-center, wheel lean, gear selection, left moldboard lift cylinder and float.

The right joystick controls drawbar, circle and moldboard functions as well as electronic throttle control and manual differential lock/unlock.

The steer tire angle matches the joystick position. A brake tensioning system holds the joystick in position until the operator moves it. The steering control automatically reduces steering sensitivity at higher ground speeds for predictable control.

Infinitely variable roller switches control the rear ripper and/or front lift group (when equipped). Optional Programmable Auxiliary Hydraulic Pod controls up to six additional hydraulic circuits.

Electronic Throttle Control

Electronic Throttle Control helps improve productivity by providing the best match of horsepower and torque for the demands of the application.

Articulation Return-to-Center

Automatically returns the machine to a straight frame position from any angle with the touch of a button.

Selectable Blade Lift Modes

Choose the blade lift modulation mode that best fits your application or operating style: Fine, Normal, or Coarse.

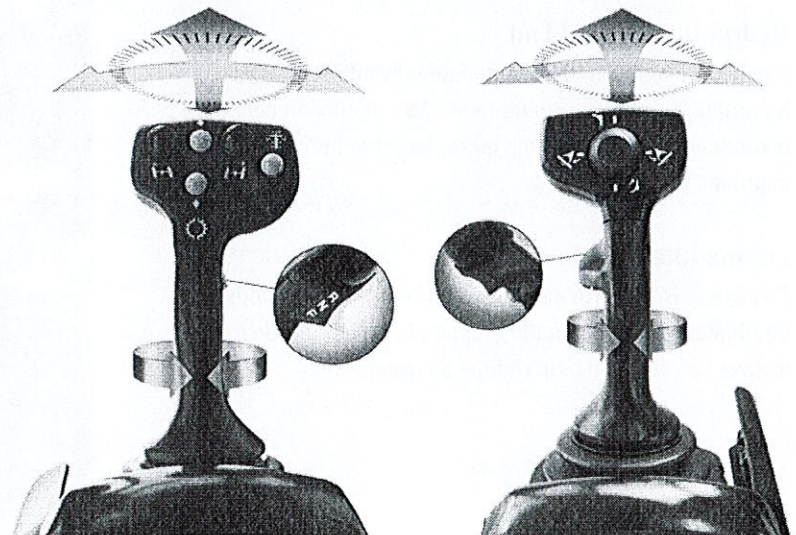

Engine

Power and reliability

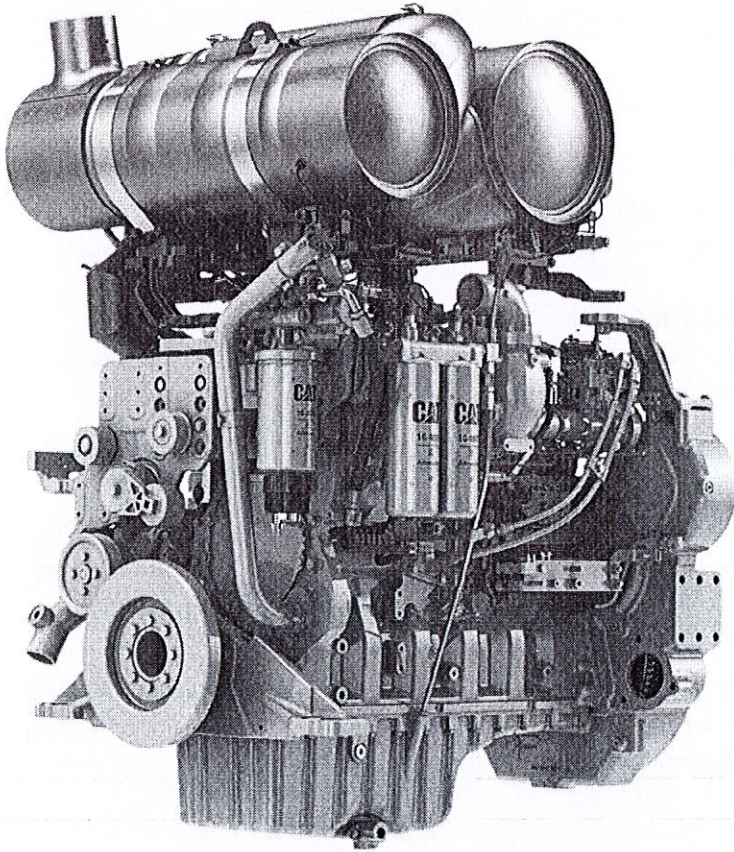

A Cat C9.3 engine gives you the performance you need to maintain consistent grading speeds for maximum productivity. Every U.S. EPA Tier 4 Final/EU Stage V engine is equipped with a combination of proven electronic, fuel, air and aftertreatment components. Applying proven technologies systematically and strategically helps meet your high expectations for productivity, fuel efficiency, reliability and service life.

Hydraulic Demand Fan

The hydraulic demand fan automatically adjusts speed according to cooling requirements. When cooling demand is reduced, you benefit from more power to the ground and improved fuel efficiency.

Engine Idle Shutdown Timer

This standard feature can be software-enabled by your Cat dealer to shut down the engine after a set period of time to save you fuel and help reduce emissions.

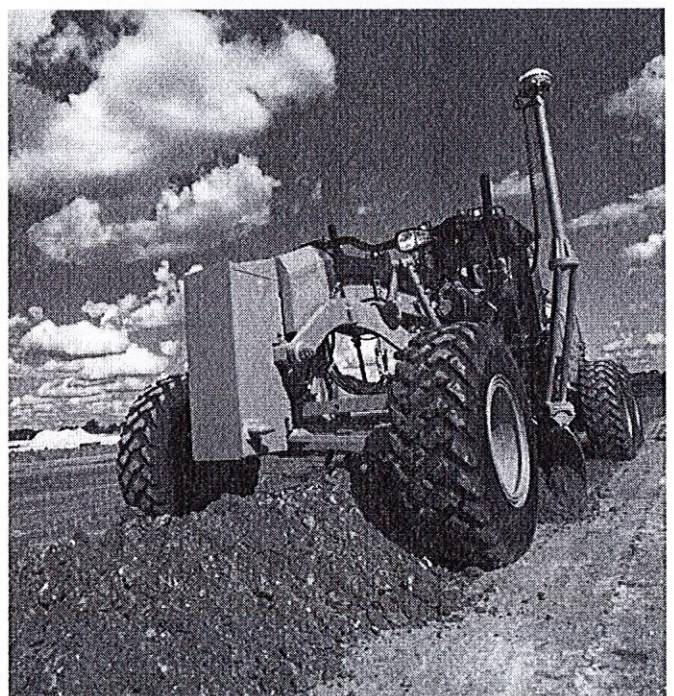

Emissions Technology

Proven, integrated solutions

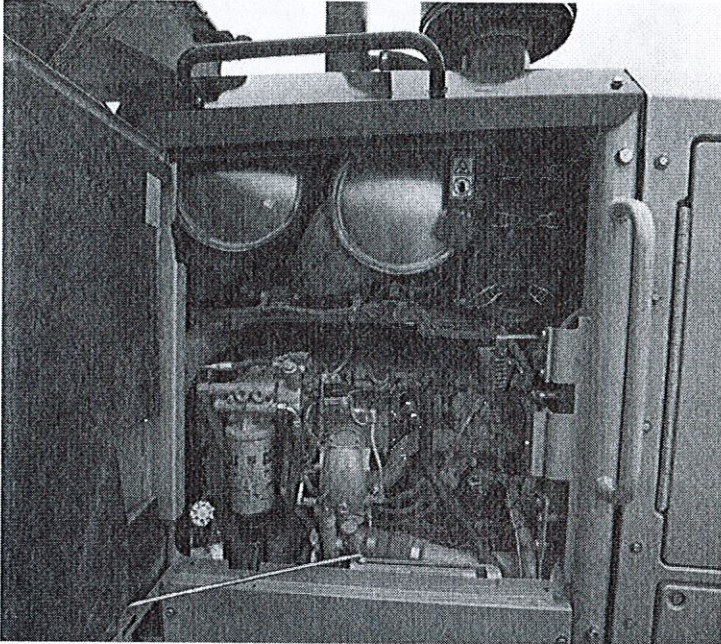

Emissions reduction technology on the 140/150/160 Motor Graders is designed to be transparent, with no action required from the operator. There is no need to stop. Regeneration runs automatically at cold start-up and, if needed, in the background while you work.

Aftertreatment Technologies

Caterpillar designed Tier 4 Interim products with Tier 4 Final standards in mind. To meet the additional 80 percent reduction in NOx emissions required by EPA Tier 4 Final/EU Stage V emission standards, Caterpillar engineers only needed to add one new system to the already proven aftertreatment solution in use, Selective Catalytic Reduction (SCR).

Diesel Exhaust Fluid

Selective Catalytic Reduction utilizes Diesel Exhaust Fluid (DEF), which can be conveniently filled from ground level. Simply refill the DEF tank when you refuel. A gauge on the dash shows your fluid level.

When you turn the machine off, a pump will automatically purge the DEF lines. A light located inside the rear engine compartment will turn off, telling you the purge is complete and that it is safe to turn off the electrical disconnect. If the engine/aftertreatment temperatures are high, a Delayed Engine Shutdown will activate automatically to cool the machine and then purge the lines.

For complete aftertreatment information, please refer to your machine's Operation and Maintenance Manual.

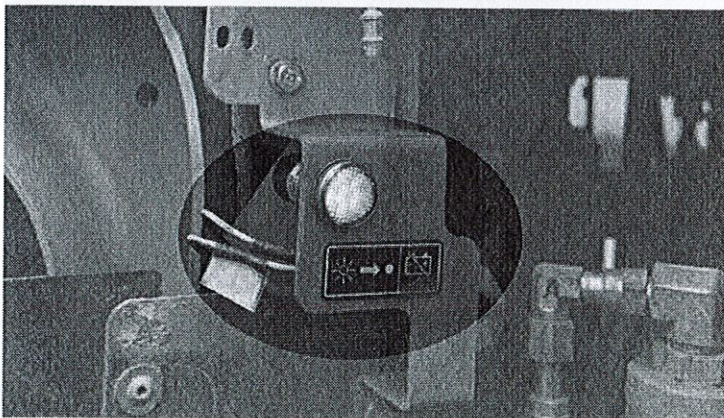
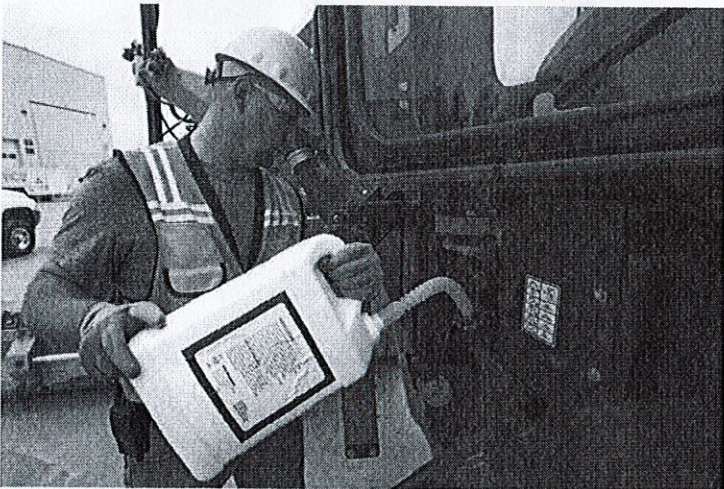

Power Train

Maximum power to the ground

- Standard Automatic Differential Lock/Unlock monitors machine and application parameters to unlock/re-lock the differential during operation, improving production and enhancing comfort while protecting the power train.
- Full Electronic Clutch Pressure Control optimizes inching modulation for smooth shifts and directional changes.
- Programmable Autoshift option simplifies operation by allowing you to program the transmission to shift at optimal points to match your application.
- New standard Economy Mode can be turned on to help save fuel by reducing engine speed so the machine works in a more efficient range. The average fuel savings is up to 10 percent, depending on the application.
- Power Shift Countershaft Transmission maximizes power to the ground.
- Engine Over-Speed Protection prevents downshifting until an acceptable safe travel speed has been established.

Front and Rear Axles

The sealed spindle keeps front axle bearings lubricated and protected from contaminants. The Cat "Live Spindle" design places the larger tapered roller bearing on the outside, where the load is greater, extending bearing life. A bolt-on modular rear axle improves serviceability and contamination control with easy access to differential components.

Hydraulic Brakes

Oil-bathed multi-disc service brakes are hydraulically actuated for smooth, predictable braking and lower operating costs. Brakes are located at each tandem wheel and have a large total brake surface area to give you dependable stopping power and longer life.

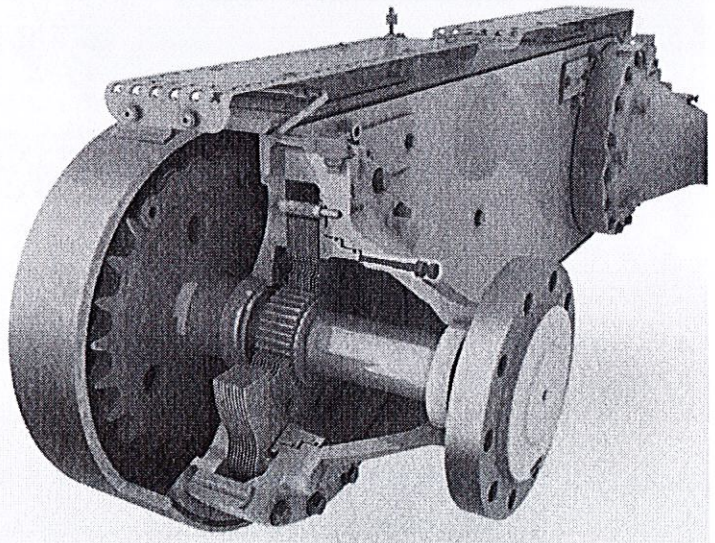
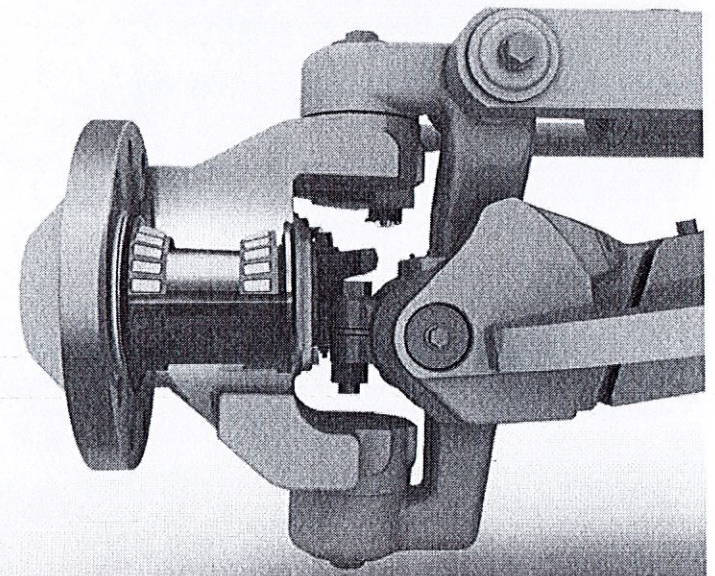
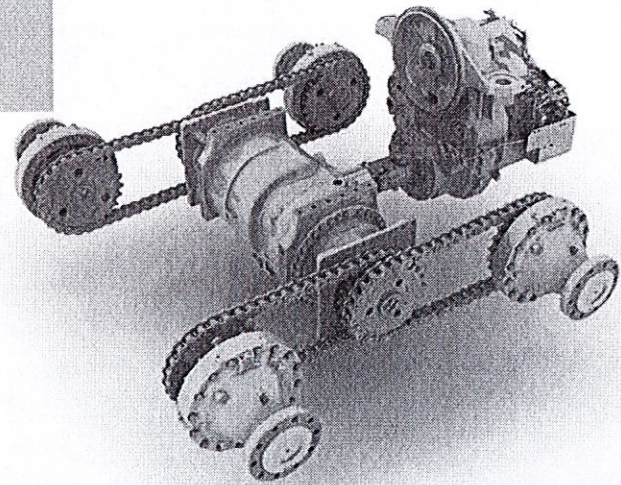

Structures and Drawbar-Circle-Moldboard

Service ease and precise blade control

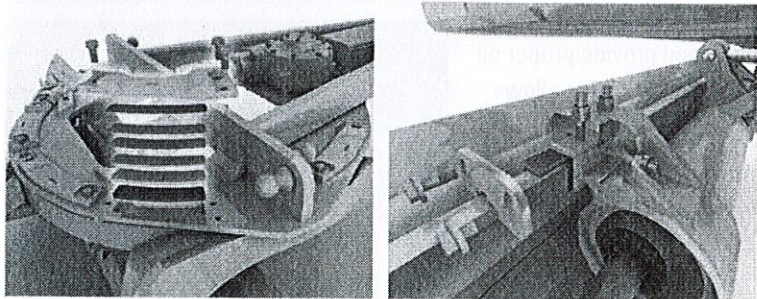
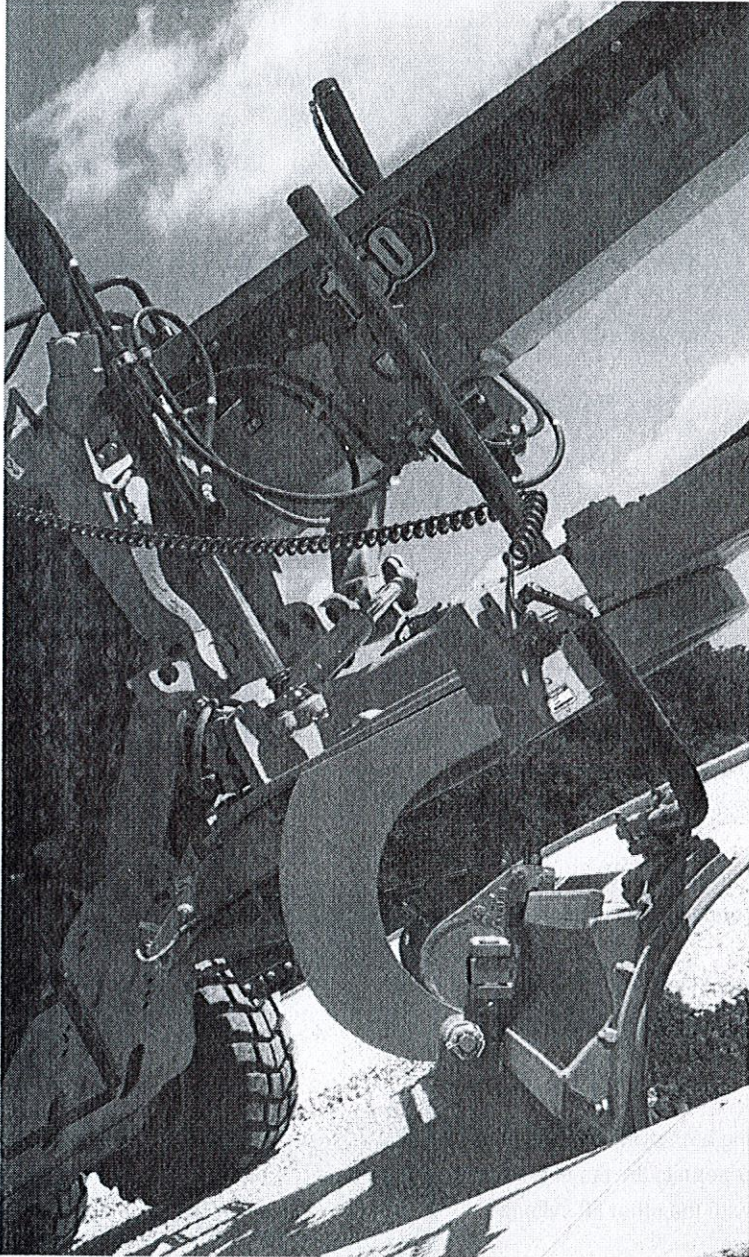

Caterpillar designs motor grader frame and drawbar components to give you performance and durability. The one-piece forged steel circle stands up to high stress loads, and a sacrificial wear system helps keep your service time and costs down.

The articulation hitch features a large tapered roller bearing to carry loads evenly and smoothly. It is sealed to prevent contamination and a locking pin prevents articulation for safety during service or transport.

Easy Maintenance for More Uptime

The drawbar, circle and moldboard are designed to make it easy to keep the components tight. One person can easily adjust or replace the patented top-adjust drawbar wear inserts from the top of the drawbar plate, reducing downtime to save you money. Durable nylon composite wear inserts maximize circle torque and component life. Sacrificial brass wears strips between the blade mounting group and moldboard can be easily adjusted and replaced. The Shimless Moldboard Retention System uses vertical and horizontal adjusting screws to keep moldboard wear strips aligned for reduced blade chatter and precise blade control.

Blade Angle and Moldboard

An aggressive blade angle, optimized moldboard curvature and large throat clearance help you work more efficiently by allowing material to roll more freely along the blade.

Heat-treated rails, hardened cutting edges and end bits, and heavy duty bolts to give you greater moldboard reliability and long service life. The link bar allows extreme moldboard positioning for easier bank sloping and ditch cutting/cleaning.

Hydraulics

Advanced machine control



Responsive Hydraulics

A proven load-sensing system and advanced electro-hydraulics give you superior implement control and responsive hydraulic performance that helps make your operator's job easier. Continuously matching hydraulic flow/pressure to power demands creates less heat and reduces power consumption.

- Consistent, Predictable Movement – Proportional Priority Pressure-Compensating (PPP-C) valves have different flow rates for the head and rod ends of the cylinder, so you can count on consistent, predictable implement response.
- Balanced Flow – Hydraulic flow is proportioned to give you confidence that all implements will operate simultaneously without slowing the engine or speed of some implements.

Blade Float

Allows the blade to move freely under its own weight. By floating both cylinders, the blade can follow the contours of the ground. Floating only one cylinder permits the toe of the blade to follow a hard surface while the operator controls the slope with the other lift cylinder.

Independent Oil Supply

Large, separate hydraulic oil supplies prevent cross-contamination and provide proper oil cooling, which reduces heat build-up and extends component life. Cat XT™ hose allows high pressures for maximum power and reduced downtime.

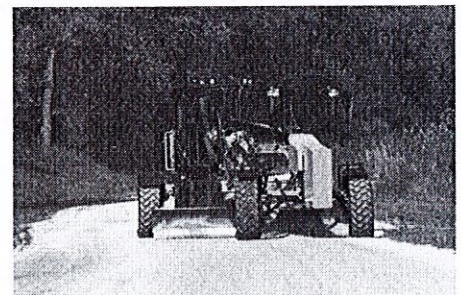
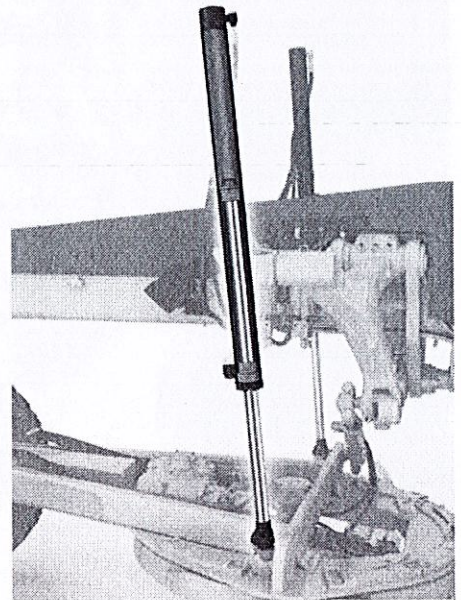

All Wheel Drive (AWD)

Expanded machine versatility

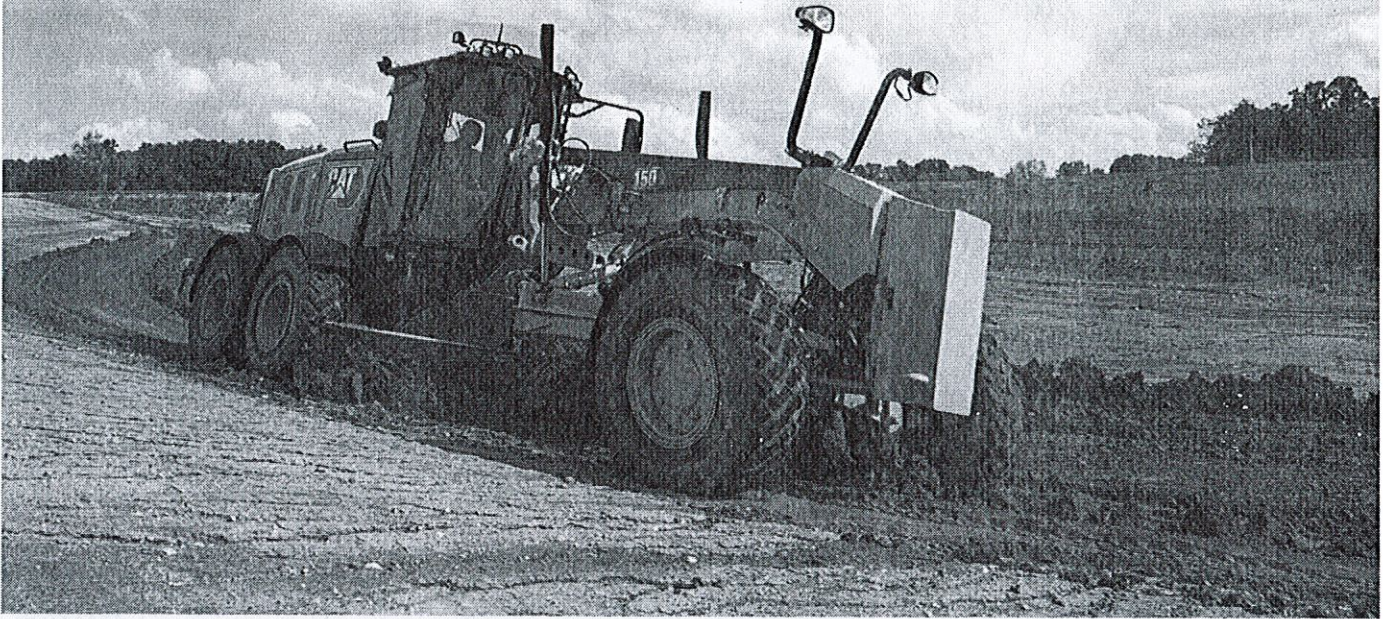

■ Without Steering Compensation ■ With Steering Compensation

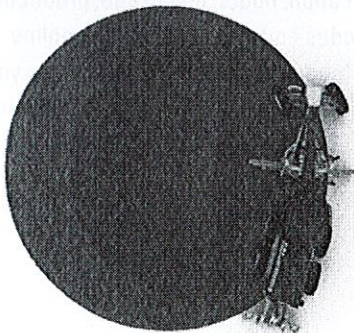

If you work in soft underfoot conditions where traction can be a challenge, optional All Wheel Drive (AWD) can give you the additional power to the ground you need to work more efficiently in mud, gravel, sand or snow. The added traction helps reduce sliding on side slopes.

- Dedicated left and right pumps give you more precise hydraulic control. The infinitely variable pumps and motors maximize torque in each gear.
- AWD automatically increases horsepower to maximize your power to the ground.
- Standard Hydrostatic Mode disengages the transmission and provides hydraulic power to the front wheels only. Infinitely variable ground speed between 0-8 km/h (0-5 mph) is ideal for precise finish work.
- Cat Steering Compensation System enables a "powered turn" by adjusting the outside front tire speed up to 50% faster than the inside tire. This gives you improved control, reduces surface damage and greatly reduces turning radius in poor underfoot conditions.

Integrated Technologies

Monitor, manage, and enhance job site operations



Cat Connect makes smart use of technology and services to improve your job site efficiency. Using the data from technology-equipped machines, you'll get more information and insight into your equipment and operations than ever before.

Cat Connect technologies offer improvements in these key areas:



EQUIPMENT
MANAGEMENT

Equipment Management – increase uptime and reduce operating costs.



PRODUCTIVITY

Productivity – monitor production and manage job site efficiency



SAFETY

Safety – enhance job site awareness to keep your people and equipment safe.

Featured Cat Connect technologies include:

Link

Link technologies provide wireless capability to machines enabling two-way transfer of information collected by on-board sensors, control modules, and other Cat Connect technologies using off-board apps, such as our VisionLink software.

Product Link™/VisionLink®

Product Link takes the guesswork out of equipment management. Track location, hours, fuel usage, productivity, idle time, diagnostic codes and more through the online VisionLink interface. Manage your fleet in real time so you can maximize efficiency, improve productivity, and lower operating costs.

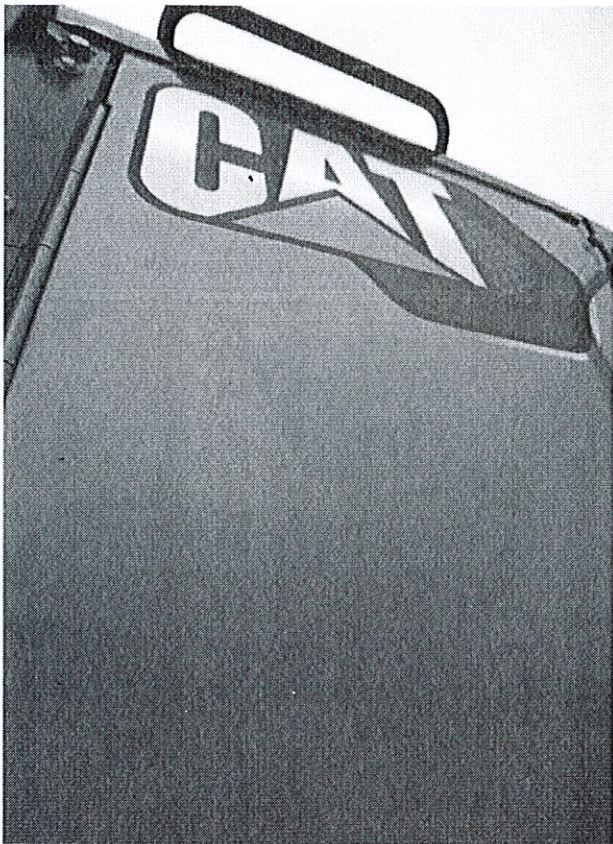

Grade

Grade technologies combine digital design data, in-cab guidance, and automatic blade controls to enhance grading accuracy, reduce rework, and lower costs related to production earthmoving and rough, fine and finish grade applications.

Cat Grade Control Cross Slope

Cat Grade Control Cross Slope is an optional fully integrated, factory installed system that helps your operator improve grading efficiency and more easily maintain accurate cross slopes. The system automatically controls one side of the blade, reducing manual operator inputs by as much as 50 percent. Experienced operators can maintain peak efficiency levels throughout more of the work day, while less experienced operators can be more productive faster. The system is job-ready from day one, and scalable for the future with AccuGrade™ upgrade kits that provide additional 2D and/or 3D control.



Cat AccuGrade

AccuGrade is an optional dealer-installed grade control system that provides higher accuracy capabilities to the Cat Cross Slope system by adding Sonic, Laser, GPS, and/or Universal Total Station (UTS) technology when the job requires. In-cab guidance helps operators work more confidently and get to grade faster, in fewer passes, using less material, improving productivity and accuracy by nearly 50 percent over conventional methods. Grade stakes and checkers are minimized, making the job site safer and more cost effective. An AccuGrade Attachment Ready Option can be ordered as a factory or dealer-installed option. It includes built-in mounting points and internal wiring for easy installation of the AccuGrade system.



Safety

Designed with protection in mind

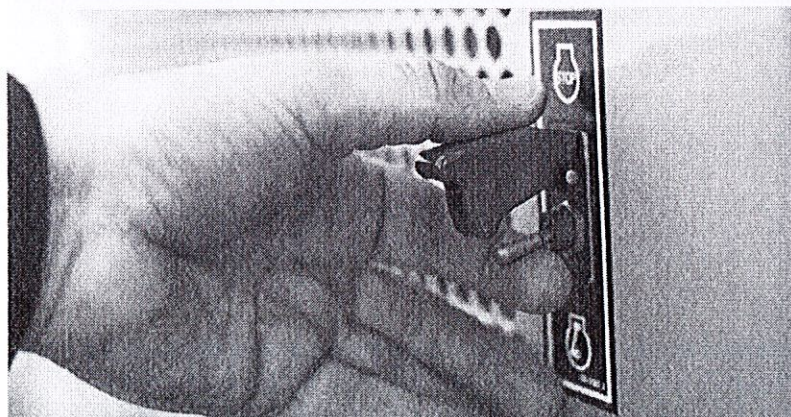
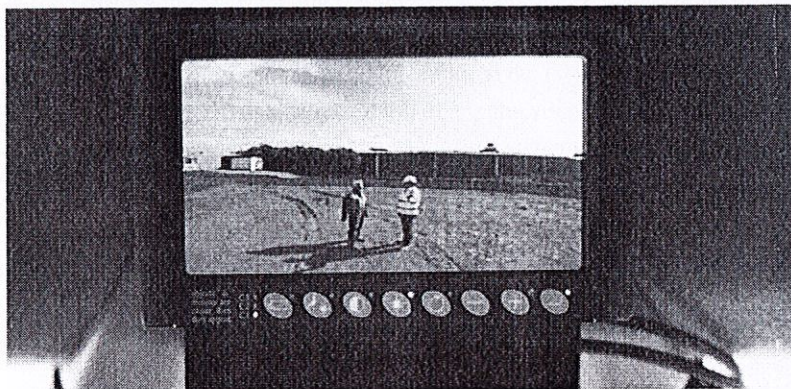

Safety Features

- Optional rearview camera with in-cab monitor
- New optional seat belt indicator light reminds operator to fasten safety belt
- Grouped, ground level service points
- Laminated front window glass
- Optional LED Lighting
- Ground-level electrical disconnect switch
- Ground-level engine shutoff switch
- Anti-glare paint eases night operation
- Optional front and rear fenders

Operator Presence Monitoring System

Standard system keeps the parking brake engaged and hydraulic implements disabled until the operator is seated and the machine is ready for operation.

Speed Sensitive Steering

Standard function makes steering less sensitive as ground speed increases for greater operator confidence and control.

Secondary Steering System

Standard feature automatically engages an electric hydraulic pump in case of a drop in steering pressure so the operator can steer the machine to a stop.

Hydraulic Lockout

Disables all implement functions while still providing machine steering control. This standard safety feature is especially useful while roading.

Brake Systems

Brakes are located at each tandem wheel to eliminate braking loads on the power train. Redundant brake systems utilize accumulators to enable stopping in case of machine failure.

Walkways and Grab Rails

Perforated steel tandem walkways and convenient grab rails give you a sturdy platform when moving on, off and around the machine.

Circle Drive Slip Clutch

Protects the drawbar, circle and moldboard from shock loads when the blade encounters an immovable object. This standard feature also reduces the possibility of abrupt directional changes in poor traction conditions.

Blade Lift Accumulators

Help absorb impact loads to the moldboard by allowing vertical blade travel. This optional feature helps reduce wear and aids operator safety.

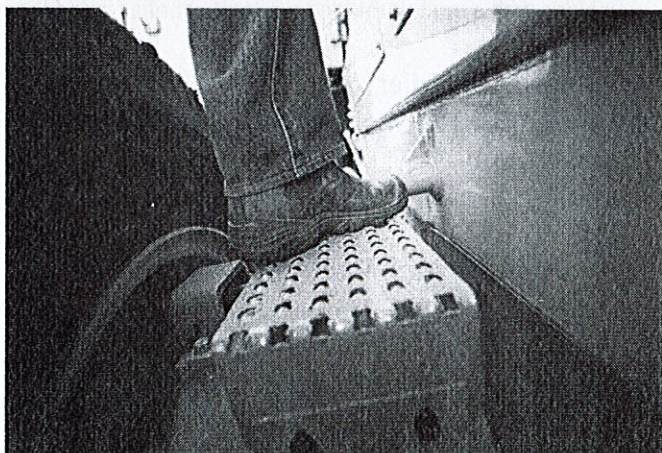
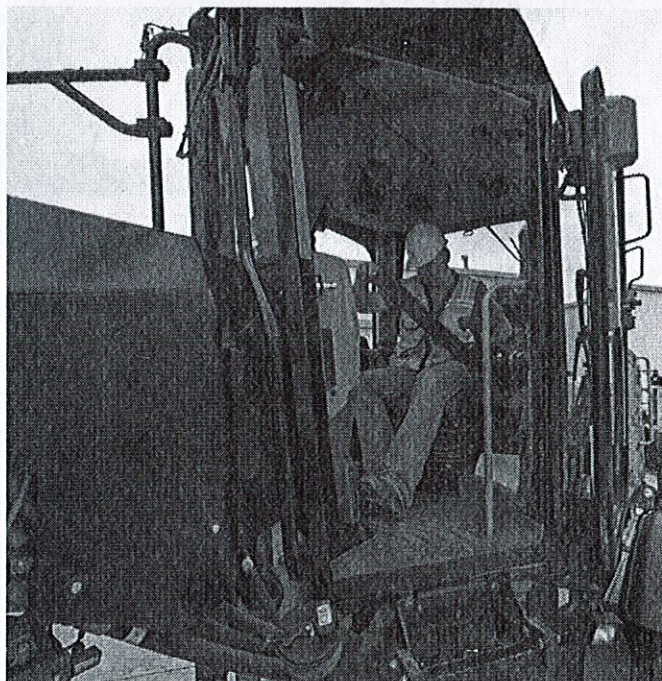
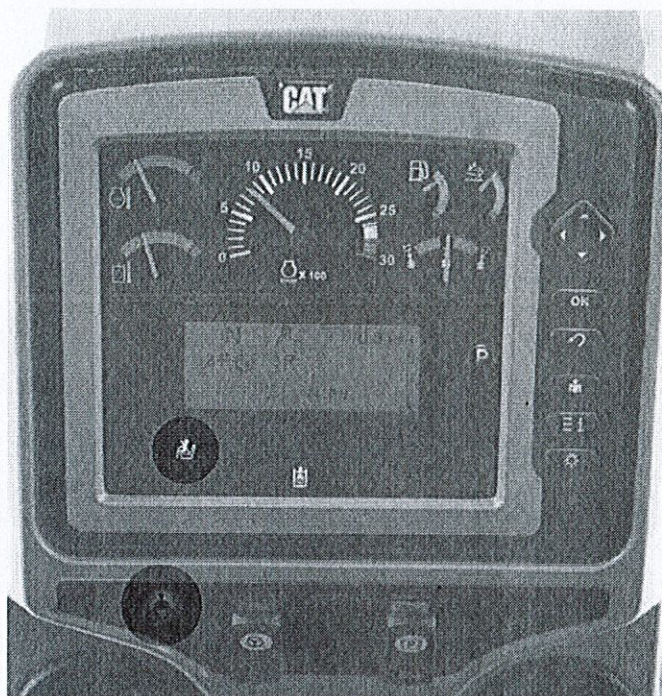

Work Tools and Attachments

Equip your machine for the job

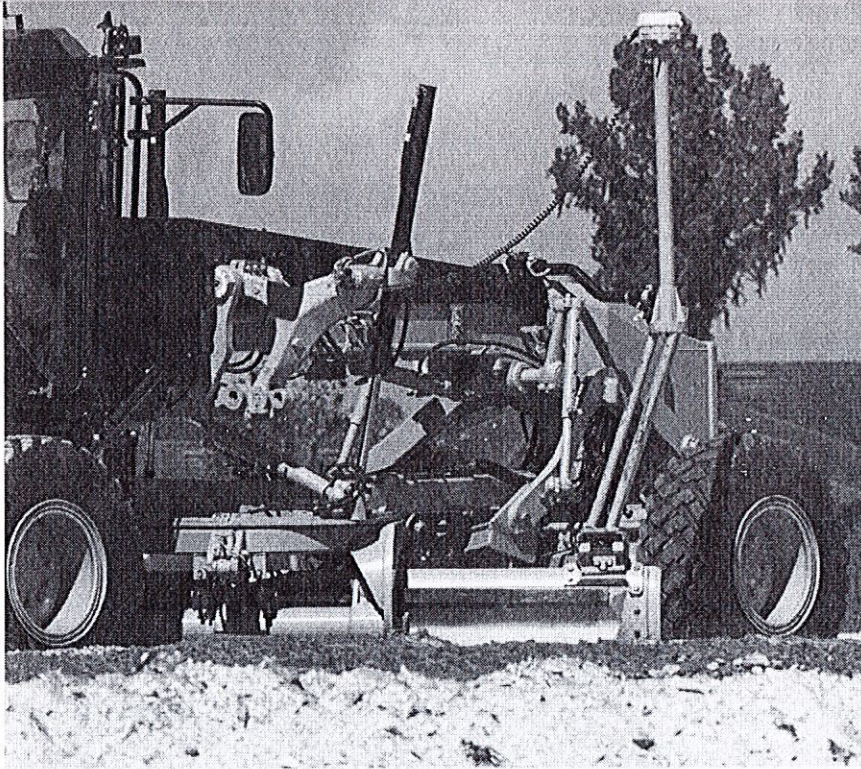

Moldboard Options

The 140, 150, and 160 motor graders come equipped with a 3.7 m (12 ft) moldboard. An optional 4.3 m (14 ft) blade is available for all models, as well as a 4.9 m (16 ft) moldboard for the 160.

Ground Engaging Tools (GET)

A variety of tools are available from Cat Work Tools, including cutting edges, graderbits and end bits, all designed for maximum service life and productivity.

Front Mounted Groups

A front mounted push plate or front lift group are available. The front lift group can be combined with a front dozer blade or front scarifier for added versatility.

Rear Ripper/Scarifier

Made to penetrate tough material fast and rip thoroughly for easier movement with the moldboard. The ripper includes three shanks (with holders for five). Nine scarifier shanks can also be added for additional versatility.

Snow Removal Work Tools

Snow plow, snow wing and mounting options increase machine versatility and utilization throughout the year.

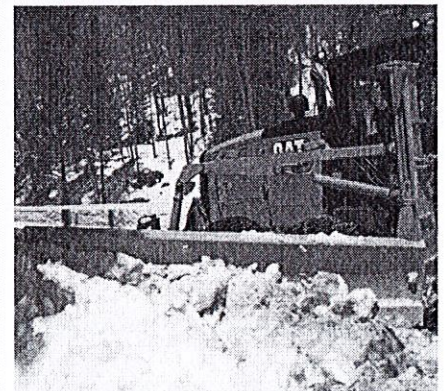
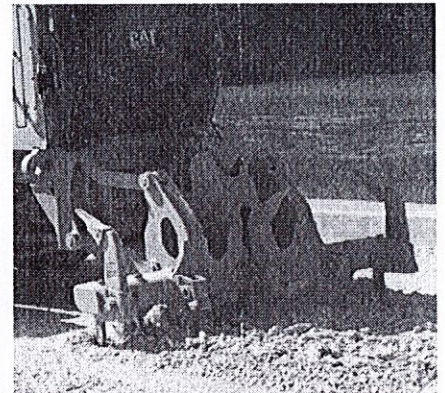

Smart Machine Systems

Advanced Diagnostics

- Cat Messenger, combined with full systems integration, enhances diagnostic capability for quick analysis of critical data.
- Electronic Technician (Cat ET) lets service technicians access stored diagnostic data and configure machine parameters through the Cat Data Link.
- Low Battery Elevated Idle raises idle speed when low system voltage is detected, ensuring adequate system voltage and improving battery reliability.
- Automatic Engine Deration protects the engine by automatically lowering engine torque output and alerting the operator if critical conditions are detected.

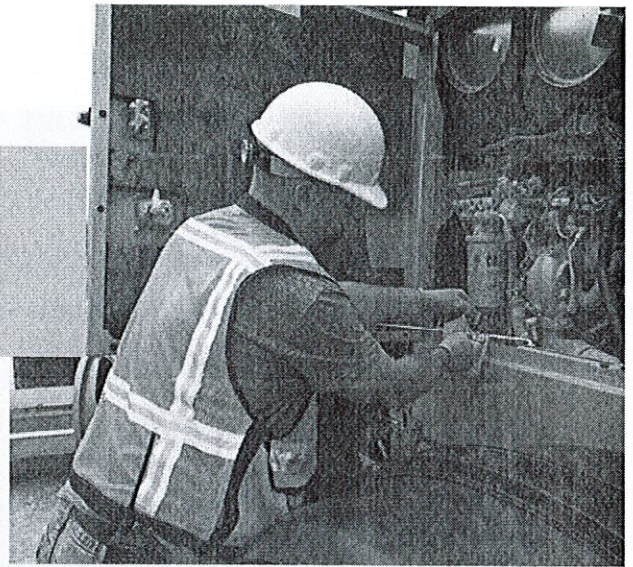

Serviceability and Customer Support

When uptime counts

Cat motor graders are designed to help you increase uptime and reduce costs. Grouped service points and extended service intervals save maintenance time. New optional LED lights in the left hand compartment makes it more convenient to service the machine in low light.

Unparalleled Dealer Support

When it comes to supporting you, Cat dealers are second to none. From machine selection and purchase to maintenance support and rebuilds, Cat dealers have the experience and capabilities to help keep you up and running.

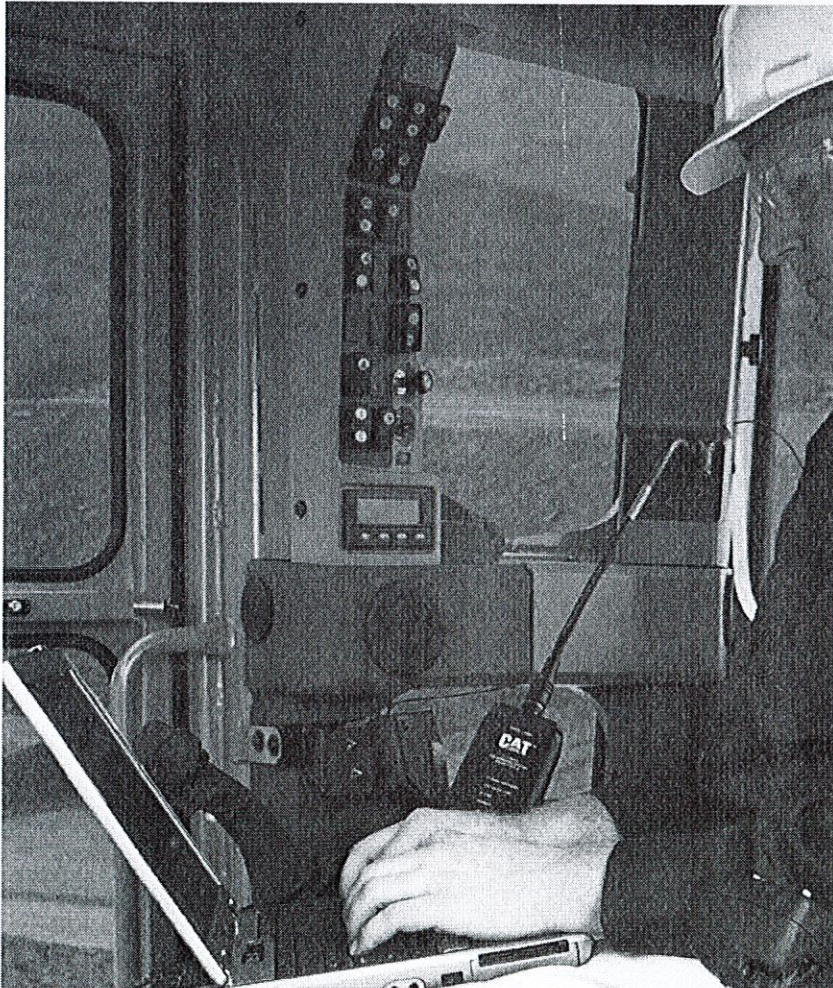

Sustainability

Thinking generations ahead



Fuel Efficiency

- Integrated machine systems and technologies improve productivity for greater accuracy, allowing the machine to do more work per gallon of fuel.
- New Economy Mode feature allows the machine to work in the most efficient engine speed range to help reduce fuel use.

Green House Gas Emissions

- Reduced fuel consumption means reduced CO₂ emissions.

Material Efficiency and Lifecycle Costs

- Replaceable wear parts save maintenance time and cost, and extend major component life.
- Major components are built to be rebuilt, eliminating waste and saving customers money by giving the machine and/or major components a second – and even third – life.
- Approximately 95% of machine materials can be recycled (ISO 16714) to conserve valuable natural resources and further enhance machine end-of-life value.

Sound

- Reduced engine noise and quieter cabs mean lower operator and spectator sound levels.

Safety

- Ecology drains help make draining fluids more convenient and help prevent spills.
- Cartridge style hydraulic fluid filters provide safe clean draining of filters prior to replacement, helping to prevent fluid spills.
- A variety of safety features help safeguard operators and others on the job site.

140/140 AWD Motor Graders Specifications

Engine

Engine Model	Cat C9.3		
Emissions	U.S. EPA Tier 4 Final/ EU Stage V		
Base Power (1st gear) – Net	133 kW	179 hp	
Base Power (1st gear) – Net (Metric)	181 hp		
VHP Plus Range – Net	133-172 kW	179-231 hp	
VHP Plus Range – Net (Metric)	181-234 hp		
AWD Range – Net	141-188 kW	189-252 hp	
AWD Range – Net (Metric)	192-255 hp		
Displacement	9.3 L	567.5 in ³	
Bore	115 mm	4.5 in	
Stroke	149 mm	5.9 in	
Torque Rise	38%		
Maximum Torque (VHP Plus)	1138 N·m	840 lb-ft	
Maximum Torque (AWD On)	1247 N·m	920 lb-ft	
Speed @ Rated Power	2,000 rpm		
Number of Cylinders	6		
Derating Altitude	3050 m	10,000 ft	
High Ambient – Fan Speed			
Standard	1,400 rpm		
Maximum	1,550 rpm		
Minimum	500 rpm		
Standard Capability	43° C	109° F	
High Ambient Capability	50° C	122° F	
Gear – Net Power	VHP Plus kW (hp)	AWD Off kW (hp)	AWD On kW (hp)
Forward			
1st	133 (179)	141 (189)	149 (200)
2nd	141 (189)	149 (200)	164 (220)
3rd	149 (200)	156 (210)	168 (225)
4th	156 (210)	160 (215)	172 (231)
5th	160 (215)	164 (220)	188 (252)
6th	164 (220)	168 (225)	188 (252)
7th	168 (225)	172 (231)	188 (252)
8th	172 (231)	172 (231)	188 (252)
Reverse			
1st	133 (179)	133 (179)	133 (179)
2nd	141 (189)	141 (189)	141 (189)
3rd–6th	149 (200)	149 (200)	149 (200)

Engine (cont'd)

- Net power is tested per ISO 9249, SAE J1349, and EEC 80/1269 Standards in effect at the time of manufacture.
- VHP Plus is standard for the 140 and 140 AWD.
- Net power advertised is the power available at rated speed of 2,000 rpm, measured at the flywheel when engine is equipped with fan running at minimum speed, air cleaner, muffler and alternator.
- No engine derating required up to 3050 m (10,000 ft).
- Power as declared per ISO 14396
Rated rpm 2,000
VHP+ = 173 kW (232 hp)
AWD = 189 kW (253 hp)
- All nonroad U.S. EPA Tier 4, European Union (EU) Stage V and Japan (MLIT) Step 4 diesel engines are required to use only Ultra Low Sulfur Diesel (ULSD) fuels containing 15 ppm (mg/kg) sulfur or less. Biodiesel blends up to B20 (20% blend by volume) are acceptable when blended with 15 ppm (mg/kg) sulfur or less ULSD. B20 should meet ASTM D7467 specification (biodiesel blend stock should meet Cat biodiesel spec, ASTM D6751 or EN 14214). Cat DEO-ULS™ or oils that meet the Cat ECF-3, API CJ-4, and ACEA E9 specification are required. Consult your OMM for further machine specific fuel recommendations.
- Cat engines equipped with a Selective Catalytic Reduction (SCR) system are required to use:
 - Diesel Exhaust Fluid (DEF) which meets the requirements outlined in the International Organization for Standardization (ISO) standard 22241-1.

Power Train

Forward/Reverse Gears	8 Forward/6 Reverse	
Transmission	APECS, Direct Drive, Powershift	
Brakes		
Service	Multiple Oil Disc	
Service, Surface Area	23 000 cm ²	3,565 in ²
Parking	Multiple Oil Disc	
Secondary	Dual Circuit	

Hydraulic System

Circuit Type	Parallel	
Pump Type	Variable Piston	
Pump Output	210 L/min	55.7 gal/min
Maximum System Pressure	24 150 kPa	3,500 psi
Reservoir Tank Capacity	64.0 L	16.9 gal
Standby Pressure	6100 kPa	885 psi

- Pump output measured at 2,150 rpm.

140/140 AWD Motor Graders Specifications

Operating Specifications

Top Speed		
Forward	46.6 km/h	29.0 mph
Reverse	36.8 km/h	23.0 mph
Turning Radius, Outside Front Tires	7.8 m	25 ft 7 in
Steering Range – Left/Right	50°	
Articulation Angle – Left/Right	20°	
Forward		
1st	4.1 km/h	2.5 mph
2nd	5.5 km/h	3.4 mph
3rd	8.0 km/h	5.0 mph
4th	11.0 km/h	6.9 mph
5th	17.1 km/h	10.6 mph
6th	23.3 km/h	14.5 mph
7th	32.0 km/h	19.9 mph
8th	46.6 km/h	29.0 mph
Reverse		
1st	3.2 km/h	2.0 mph
2nd	6.0 km/h	3.7 mph
3rd	8.7 km/h	5.4 mph
4th	13.5 km/h	8.4 mph
5th	25.3 km/h	15.7 mph
6th	36.8 km/h	23.0 mph

• Calculated with no slip and 14.0R24 tires.

Service Refill

Fuel Capacity	394 L	104 gal
Cooling System	57.0 L	15.0 gal
Hydraulic System		
Total	100 L	26.4 gal
Tank	64.0 L	16.9 gal
Engine Oil	30.0 L	7.9 gal
Trans./Diff./Final Drives	70.0 L	18.5 gal
Tandem Housing (Each)	76.0 L	20.0 gal
Front Wheel Spindle Bearing Housing	0.5 L	0.13 gal
Circle Drive Housing	7.0 L	1.8 gal
Diesel Exhaust Fluid	22.0 L	5.8 gal

Frame

Circle		
Diameter	1530 mm	60.2 in
Height	138 mm	5.4 in
Blade Beam Thickness	40.0 mm	1.6 in
Drawbar		
Height	152 mm	6.0 in
Width	76.2 mm	3.0 in
Thickness	12.7 mm	0.50 in
Front-Top/Bottom Plate		
Width	305 mm	12.0 in
Thickness	22.0 mm	0.87 in
Front Frame Structure		
Height	321 mm	12.6 in
Width	305 mm	12.0 in
Front Axle		
Height to Center	596 mm	23.5 in
Wheel Lean, Left/Right	18°	
Total Oscillation per Side	32°	

• Front-top/bottom plate – width tolerance ± 2.5 mm (0.098 in).

Tandems

Height	506 mm	19.9 in
Width	201 mm	7.9 in
Sidewall Thickness		
Inner	16.0 mm	0.63 in
Outer	18.0 mm	0.71 in
Drive Chain Pitch	50.8 mm	2.0 in
Wheel Axle Spacing	1523 mm	60.0 in
Tandem Oscillation		
Front Up	15°	
Front Down	25°	

140/140 AWD Motor Graders Specifications

Moldboard

Blade Width	3.7 m	12 ft
Moldboard		
Height	610 mm	24.0 in
Thickness	22.0 mm	0.87 in
Arc Radius	413 mm	16.3 in
Throat Clearance	166 mm	6.5 in
Cutting Edge		
Width	152 mm	6.0 in
Thickness	16.0 mm	0.60 in
End Bit		
Width	152 mm	6.0 in
Thickness	16.0 mm	0.60 in
Blade Pull		
Base GVW	11 462 kg	25,269 lb
Maximum GVW	15 541 kg	34,262 lb
Base GVW (AWD)	16 170 kg	35,649 lb
Maximum GVW (AWD)	22 512 kg	49,630 lb
Blade Down Pressure		
Base GVW	7275 kg	16,038 lb
Maximum GVW	13 294 kg	29,309 lb
Base GVW (AWD)	8151 kg	17,970 lb
Maximum GVW (AWD)	13 294 kg	29,309 lb

Blade Range

Circle Centershift		
Right	728 mm	28.7 in
Left	695 mm	27.4 in
Moldboard Sideshift		
Right	660 mm	26.0 in
Left	510 mm	20.1 in
Maximum Blade Position Angle	90°	
Blade Tip Range		
Forward	40°	
Backward	5°	
Maximum Shoulder Reach Outside of Tires		
Right	1978 mm	77.9 in
Left	1790 mm	70.5 in
Maximum Lift Above Ground	480 mm	18.9 in
Maximum Depth of Cut	715 mm	28.1 in

Ripper

Ripping Depth, Maximum	426 mm	16.8 in
Ripper Shank Holders	5	
Ripper Shank Holder Spacing	533 mm	21.0 in
Penetration Force	9440 kg	20,812 lb
Pryout Force	12 607 kg	27,794 lb
Machine Length Increase, Beam Raised	1031 mm	40.6 in

Scarifier

Front, V-Type: Working Width	1205 mm	47.4 in
Front, V-Type, 5 or 11 Tooth		
Working Width	1031 mm	40.6 in
Scarifying Depth, Maximum	467 mm	18.4 in
Scarifier Shank Holders	5/11	
Scarifier Shank Holder Spacing	116 mm	4.6 in
Mid, V-Type		
Working Width	1184 mm	46.6 in
Scarifying Depth, Maximum	292 mm	11.5 in
Scarifier Shank Holders	11	
Scarifier Shank Holder Spacing	116 mm	4.6 in
Rear		
Working Width	2133 mm	84.0 in
Scarifying Depth, Maximum	426 mm	16.8 in
Scarifier Shank Holders	9	
Scarifier Shank Holder Spacing	267 mm	10.5 in

Weights

Gross Vehicle Weight, Base		
Total	16 974 kg	37,420 lb
Front Axle	4238 kg	9,343 lb
Rear Axle	12 736 kg	28,077 lb
Gross Vehicle Weight, Maximum		
Total	25 013 kg	55,144 lb
Front Axle	7745 kg	17,075 lb
Rear Axle	17 268 kg	38,069 lb
Operating Weight, Typically Equipped		
Total	19 344 kg	42,647 lb
Front Axle	5468 kg	12,055 lb
Rear Axle	13 876 kg	30,592 lb

140/140 AWD Motor Graders Specifications

Weights – AWD

Gross Vehicle Weight, Base		
Total	17 966 kg	39,609 lb
Front Axle	4749 kg	10,469 lb
Rear Axle	13 217 kg	29,140 lb
Gross Vehicle Weight, Maximum		
Total	25 013 kg	55,144 lb
Front Axle	7745 kg	17,075 lb
Rear Axle	17 268 kg	38,069 lb
Operating Weight, Typically Equipped		
Total	20 236 kg	44,614 lb
Front Axle	5945 kg	13,107 lb
Rear Axle	14 291 kg	31,507 lb

- Base operating weight on standard machine configuration is calculated with full fuel tank, coolant, lubricants, operator and 14.0R24 tires with single-piece (SP) rims.
- Typically equipped operating weight is calculated with push block, rear ripper/scarifier, 14.0R24 tires with single-piece (SP) rims, and other equipment.

Standards

ROPS/FOPS	ISO 3471/ISO 3499
Steering	ISO 5010
Brakes	ISO 3450
Sound	ISO 6394; ISO 6395

- The declared dynamic operator sound pressure level is 71 dB(A) for the 140 and 140 AWD when “ISO 6396:2008” is used to measure the value for a European Union “CE” marked machine. The measurement was conducted at 70% of the maximum engine cooling fan speed. The sound level may vary at different engine cooling fan speeds.
- The declared exterior sound power level is 107 dB(A) for the 140 and 140 AWD when the value is measured according to the dynamic test procedures and the conditions that are specified in “ISO 6395:2008.” The measurement was conducted for a European Union “CE” marked machine at 70% of the maximum engine cooling fan speed. The sound level may vary at different engine cooling fan speeds and during diesel particulate filter regeneration.

Air Conditioning System

The air conditioning system on this machine contains the fluorinated greenhouse gas refrigerant R134a (Global Warming Potential = 1430). The system contains 1.8 kg of refrigerant which has a CO₂ equivalent of 2.574 metric tonnes.

150/150 AWD Motor Graders Specifications

Engine

Engine Model	Cat C9.3		
Emissions	U.S. EPA Tier 4 Final/ EU Stage V		
Base Power (1st gear) – Net	149 kW	200 hp	
Base Power (1st gear) – Net (Metric)	202 hp		
VHP Plus Range – Net	149-188 kW	200-252 hp	
VHP Plus Range – Net (Metric)	202-255 hp		
AWD Range – Net	156-203 kW	210-272 hp	
AWD Range – Net (Metric)	213-276 hp		
Displacement	9.3 L	567.5 in ³	
Bore	115 mm	4.5 in	
Stroke	149 mm	5.9 in	
Torque Rise	39%		
Maximum Torque (VHP Plus)	1247 N·m	920 lb-ft	
Maximum Torque (AWD On)	1355 N·m	1,000 lb-ft	
Speed @ Rated Power	2,000 rpm		
Number of Cylinders	6		
Derating Altitude	3050 m	10,000 ft	
High Ambient – Fan Speed			
Standard	1,400 rpm		
Maximum	1,550 rpm		
Minimum	500 rpm		
Standard Capability	43° C	109° F	
High Ambient Capability	50° C	122° F	
Gear – Net Power	VHP Plus kW (hp)	AWD Off kW (hp)	AWD On kW (hp)
Forward			
1st	149 (200)	156 (210)	164 (220)
2nd	156 (210)	164 (220)	180 (241)
3rd	164 (220)	172 (231)	184 (247)
4th	172 (231)	176 (236)	188 (252)
5th	176 (236)	180 (241)	203 (272)
6th	180 (241)	184 (247)	203 (272)
7th	184 (247)	188 (252)	203 (272)
8th	188 (252)	188 (252)	203 (272)
Reverse			
1st	149 (200)	149 (200)	149 (200)
2nd	156 (210)	156 (210)	156 (210)
3rd–6th	164 (220)	164 (220)	164 (220)

Engine (cont'd)

- Net power is tested per ISO 9249, SAE J1349, and EEC 80/1269 Standards in effect at the time of manufacture.
- VHP Plus is standard for the 150/150 AWD.
- Net power advertised is the power available at rated speed of 2,000 rpm, measured at the flywheel when engine is equipped with fan running at minimum speed, air cleaner, muffler and alternator.
- No engine derating required up to 3050 m (10,000 ft).
- Power as declared per ISO 14396
Rated rpm 2,000
VHP+ = 189 kW (253 hp)
AWD = 204 kW (274 hp)
- All nonroad U.S. EPA Tier 4, European Union (EU) Stage V and Japan (MLIT) Step 4 diesel engines are required to use only Ultra Low Sulfur Diesel (ULSD) fuels containing 15 ppm (mg/kg) sulfur or less. Biodiesel blends up to B20 (20% blend by volume) are acceptable when blended with 15 ppm (mg/kg) sulfur or less ULSD. B20 should meet ASTM D7467 specification (biodiesel blend stock should meet Cat biodiesel spec, ASTM D6751 or EN 14214). Cat DEO-ULS or oils that meet the Cat ECF-3, API CJ-4, and ACEA E9 specification are required. Consult your OMM for further machine specific fuel recommendations.
- Cat engines equipped with a Selective Catalytic Reduction (SCR) system are required to use:
 - Diesel Exhaust Fluid (DEF) which meets the requirements outlined in the International Organization for Standardization (ISO) standard 22241-1.

Power Train

Forward/Reverse Gears	8 Forward/6 Reverse	
Transmission	APECS, Direct Drive, Powershift	
Brakes		
Service	Multiple Oil Disc	
Service, Surface Area	23 000 cm ²	3,565 in ²
Parking	Multiple Oil Disc	
Secondary	Dual Circuit	

Hydraulic System

Circuit Type	Parallel	
Pump Type	Variable Piston	
Pump Output	210 L/min	55.7 gal/min
Maximum System Pressure	24 150 kPa	3,500 psi
Reservoir Tank Capacity	64.0 L	16.9 gal
Standby Pressure	6100 kPa	885 psi

- Pump output measured at 2,150 rpm.

150/150 AWD Motor Graders Specifications

Operating Specifications

Top Speed		
Forward	46.6 km/h	29.0 mph
Reverse	36.8 km/h	23.0 mph
Turning Radius, Outside Front Tires	7.8 m	25 ft 7 in
Steering Range – Left/Right	50°	
Articulation Angle – Left/Right	20°	
Forward		
1st	4.1 km/h	2.5 mph
2nd	5.5 km/h	3.4 mph
3rd	8.0 km/h	5.0 mph
4th	11.0 km/h	6.9 mph
5th	17.1 km/h	10.6 mph
6th	23.3 km/h	14.5 mph
7th	32.0 km/h	19.9 mph
8th	46.6 km/h	29.0 mph
Reverse		
1st	3.2 km/h	2.0 mph
2nd	6.0 km/h	3.7 mph
3rd	8.7 km/h	5.4 mph
4th	13.5 km/h	8.4 mph
5th	25.3 km/h	15.7 mph
6th	36.8 km/h	23.0 mph

• Calculated with no slip and 14.0R24 tires.

Service Refill

Fuel Capacity	394 L	104 gal
Cooling System	57.0 L	15.0 gal
Hydraulic System		
Total	100 L	26.4 gal
Tank	64.0 L	16.9 gal
Engine Oil	30.0 L	7.9 gal
Trans./Diff./Final Drives	70.0 L	18.5 gal
Tandem Housing (Each)	76.0 L	20.0 gal
Front Wheel Spindle Bearing Housing	0.5 L	0.13 gal
Circle Drive Housing	7.0 L	1.8 gal
Diesel Exhaust Fluid	22.0 L	5.8 gal

Frame

Circle		
Diameter	1530 mm	60.2 in
Height	138 mm	5.4 in
Blade Beam Thickness	40.0 mm	1.6 in
Drawbar		
Height	152 mm	6.0 in
Width	76.2 mm	3.0 in
Thickness	12.7 mm	0.50 in
Front-Top/Bottom Plate		
Width	305 mm	12.0 in
Thickness	22.0 mm	0.87 in
Front Frame Structure		
Height	321 mm	12.6 in
Width	305 mm	12.0 in
Front Axle		
Height to Center	596 mm	23.5 in
Wheel Lean, Left/Right	18°	
Total Oscillation per Side	32°	

• Front-top/bottom plate – width tolerance ± 2.5 mm (0.098 in).

Tandems

Height	506 mm	19.9 in
Width	201 mm	7.9 in
Sidewall Thickness		
Inner	16.0 mm	0.63 in
Outer	18.0 mm	0.71 in
Drive Chain Pitch	50.8 mm	2.0 in
Wheel Axle Spacing	1523 mm	60.0 in
Tandem Oscillation		
Front Up	15°	
Front Down	25°	

150/150 AWD Motor Graders Specifications

Moldboard

Blade Width	3.7 m	12 ft
Moldboard		
Height	610 mm	24.0 in
Thickness	22.0 mm	0.87 in
Arc Radius	413 mm	16.3 in
Throat Clearance	166 mm	6.5 in
Cutting Edge		
Width	152 mm	6.0 in
Thickness	16.0 mm	0.60 in
End Bit		
Width	152 mm	6.0 in
Thickness	16.0 mm	0.60 in
Blade Pull		
Base GVW	11 672 kg	25,732 lb
Maximum GVW	15 541 kg	34,262 lb
Base GVW (AWD)	16 484 kg	36,341 lb
Maximum GVW (AWD)	22 512 kg	49,630 lb
Blade Down Pressure		
Base GVW	7475 kg	16,480 lb
Maximum GVW	13 294 kg	29,308 lb
Base GVW (AWD)	8351 kg	18,411 lb
Maximum GVW (AWD)	13 294 kg	29,308 lb

Blade Range

Circle Centershift		
Right	728 mm	28.7 in
Left	695 mm	27.4 in
Moldboard Sideshift		
Right	660 mm	26.0 in
Left	510 mm	20.1 in
Maximum Blade Position Angle	90°	
Blade Tip Range		
Forward	40°	
Backward	5°	
Maximum Shoulder Reach Outside of Tires		
Right	1978 mm	77.9 in
Left	1790 mm	70.5 in
Maximum Lift Above Ground	480 mm	18.9 in
Maximum Depth of Cut	715 mm	28.1 in

Ripper

Ripping Depth, Maximum	426 mm	16.8 in
Ripper Shank Holders	5	
Ripper Shank Holder Spacing	533 mm	21.0 in
Penetration Force	9440 kg	20,812 lb
Pryout Force	12 607 kg	27,794 lb
Machine Length Increase, Beam Raised	1031 mm	40.6 in

Scarifier

Front, V-Type: Working Width	1205 mm	47.4 in
Front, V-Type, 5 or 11 Tooth		
Working Width	1031 mm	40.6 in
Scarifying Depth, Maximum	467 mm	18.4 in
Scarifier Shank Holders	5/11	
Scarifier Shank Holder Spacing	116 mm	4.6 in
Mid, V-Type		
Working Width	1184 mm	46.6 in
Scarifying Depth, Maximum	292 mm	11.5 in
Scarifier Shank Holders	11	
Scarifier Shank Holder Spacing	116 mm	4.6 in
Rear		
Working Width	2133 mm	84.0 in
Scarifying Depth, Maximum	426 mm	16.8 in
Scarifier Shank Holders	9	
Scarifier Shank Holder Spacing	267 mm	10.5 in

Weights

Gross Vehicle Weight, Base		
Total	17 323 kg	38,191 lb
Front Axle	4355 kg	9,601 lb
Rear Axle	12 968 kg	28,590 lb
Gross Vehicle Weight, Maximum		
Total	25 013 kg	55,144 lb
Front Axle	7745 kg	17,075 lb
Rear Axle	17 268 kg	38,069 lb
Operating Weight, Typically Equipped		
Total	19 935 kg	43,950 lb
Front Axle	5692 kg	12,549 lb
Rear Axle	14 243 kg	31,401 lb

150/150 AWD Motor Graders Specifications

Weights – AWD

Gross Vehicle Weight, Base		
Total	18 316 kg	40,380 lb
Front Axle	4865 kg	10,726 lb
Rear Axle	13 451 kg	29,654 lb
Gross Vehicle Weight, Maximum		
Total	25 013 kg	55,144 lb
Front Axle	7745 kg	17,075 lb
Rear Axle	17 268 kg	38,069 lb
Operating Weight, Typically Equipped		
Total	20 827 kg	45,917 lb
Front Axle	6169 kg	13,601 lb
Rear Axle	14 658 kg	32,316 lb

- Base operating weight on standard machine configuration is calculated with full fuel tank, coolant, lubricants, operator and 14.0R24 tires with multi-piece (MP) rims.
- Typically equipped operating weight is calculated with push block, transmission guard, rear ripper/scarifier, 14.0R24 tires with multi-piece (MP) rims, and other equipment.

Standards

ROPS/FOPS	ISO 3471/ISO 3499
Steering	ISO 5010
Brakes	ISO 3450
Sound	ISO 6394; ISO 6395

- The declared dynamic operator sound pressure level is 71 dB(A) for the 150 and 150 AWD when “ISO 6396:2008” is used to measure the value for a European Union “CE” marked machine. The measurement was conducted at 70% of the maximum engine cooling fan speed. The sound level may vary at different engine cooling fan speeds.
- The declared exterior sound power level is 107 dB(A) for the 150 and 150 AWD when the value is measured according to the dynamic test procedures and the conditions that are specified in “ISO 6395:2008.” The measurement was conducted for a European Union “CE” marked machine at 70% of the maximum engine cooling fan speed. The sound level may vary at different engine cooling fan speeds and during diesel particulate filter regeneration.

Air Conditioning System

The air conditioning system on this machine contains the fluorinated greenhouse gas refrigerant R134a (Global Warming Potential = 1430). The system contains 1.8 kg of refrigerant which has a CO₂ equivalent of 2.574 metric tonnes.

160/160 AWD Motor Graders Specifications

Engine

Engine Model	Cat C9.3		
Emissions	U.S. EPA Tier 4 Final/ EU Stage V		
Base Power (1st gear) – Net	165 kW	221 hp	
Base Power (1st gear) – Net (Metric)	224 hp		
VHP Plus Range – Net	165-203 kW	221-272 hp	
VHP Plus Range – Net (Metric)	224-276 hp		
AWD Range – Net	172-219 kW	231-293 hp	
AWD Range – Net (Metric)	234-298 hp		
Displacement	9.3 L	567.5 in ³	
Bore	115 mm	4.5 in	
Stroke	149 mm	5.9 in	
Torque Rise	39%		
Maximum Torque (VHP Plus)	1355 N·m	1,000 lb-ft	
Maximum Torque (AWD On)	1464 N·m	1,079 lb-ft	
Speed @ Rated Power	2,000 rpm		
Number of Cylinders	6		
Derating Altitude	3050 m	10,000 ft	
High Ambient – Fan Speed			
Standard	1,400 rpm		
Maximum	1,550 rpm		
Minimum	500 rpm		
Standard Capability	43° C	109° F	
High Ambient Capability	50° C	122° F	
Gear – Net Power	VHP Plus kW (hp)	AWD Off kW (hp)	AWD On kW (hp)
Forward			
1st	165 (221)	172 (231)	180 (241)
2nd	172 (231)	180 (241)	195 (262)
3rd	180 (241)	188 (252)	199 (267)
4th	188 (252)	191 (257)	203 (272)
5th	191 (257)	195 (262)	219 (293)
6th	195 (262)	199 (267)	219 (293)
7th	199 (267)	203 (272)	219 (293)
8th	203 (272)	203 (272)	219 (293)
Reverse			
1st	165 (221)	165 (221)	165 (221)
2nd	172 (231)	172 (231)	172 (231)
3rd–6th	180 (241)	180 (241)	180 (241)

Engine (cont'd)

- Net power is tested per ISO 9249, SAE J1349, and EEC 80/1269 Standards in effect at the time of manufacture.
- VHP Plus is standard for the 160/160 AWD.
- Net power advertised is the power available at rated speed of 2,000 rpm, measured at the flywheel when engine is equipped with fan running at minimum speed, air cleaner, muffler and alternator.
- No engine derating required up to 3050 m (10,000 ft).
- Power as declared per ISO 14396
Rated rpm 2,000
VHP+ = 204 kW (274 hp)
AWD = 220 kW (295 hp)
- All nonroad U.S. EPA Tier 4, European Union (EU) Stage V and Japan (MLIT) Step 4 diesel engines are required to use only Ultra Low Sulfur Diesel (ULSD) fuels containing 15 ppm (mg/kg) sulfur or less. Biodiesel blends up to B20 (20% blend by volume) are acceptable when blended with 15 ppm (mg/kg) sulfur or less ULSD. B20 should meet ASTM D7467 specification (biodiesel blend stock should meet Cat biodiesel spec, ASTM D6751 or EN 14214). Cat DEO-ULS or oils that meet the Cat ECF-3, API CJ-4, and ACEA E9 specification are required. Consult your OMM for further machine specific fuel recommendations.
- Cat engines equipped with a Selective Catalytic Reduction (SCR) system are required to use:
– Diesel Exhaust Fluid (DEF) which meets the requirements outlined in the International Organization for Standardization (ISO) standard 22241-1.

Power Train

Forward/Reverse Gears	8 Forward/6 Reverse	
Transmission	APECS, Direct Drive, Powershift	
Brakes		
Service	Multiple Oil Disc	
Service, Surface Area	23 000 cm ²	3,565 in ²
Parking	Multiple Oil Disc	
Secondary	Dual Circuit Control	

Hydraulic System

Circuit Type	Parallel	
Pump Type	Variable Piston	
Pump Output	210 L/min	55.5 gal/min
Maximum System Pressure	24 150 kPa	3,503 psi
Reservoir Tank Capacity	64.0 L	16.9 gal
Standby Pressure	6100 kPa	885 psi

- Pump output measured at 2,150 rpm.

160/160 AWD Motor Graders Specifications

Operating Specifications

Top Speed		
Forward	47.4 km/h	29.5 mph
Reverse	37.4 km/h	23.3 mph
Turning Radius, Outside Front Tires	7.8 m	25 ft 7 in
Steering Range – Left/Right	50°	
Articulation Angle – Left/Right	20°	
Forward		
1st	4.1 km/h	2.6 mph
2nd	5.6 km/h	3.5 mph
3rd	8.1 km/h	5.1 mph
4th	11.2 km/h	7.0 mph
5th	17.4 km/h	10.8 mph
6th	23.7 km/h	14.7 mph
7th	32.6 km/h	20.3 mph
8th	47.4 km/h	29.5 mph
Reverse		
1st	3.3 km/h	2.0 mph
2nd	6.1 km/h	3.8 mph
3rd	8.8 km/h	5.5 mph
4th	13.7 km/h	8.5 mph
5th	25.7 km/h	16.0 mph
6th	37.4 km/h	23.3 mph

• Calculated with no slip and 14.0R24 tires.

Service Refill

Fuel Capacity	394 L	104 gal
Cooling System	57.0 L	15.0 gal
Hydraulic System		
Total	100 L	26.4 gal
Tank	64.0 L	16.9 gal
Engine Oil	30.0 L	7.9 gal
Trans./Diff./Final Drives	70.0 L	18.5 gal
Tandem Housing (Each)	87.0 L	22.9 gal
Front Wheel Spindle Bearing Housing	0.5 L	0.13 gal
Circle Drive Housing	7.0 L	1.8 gal
Diesel Exhaust Fluid	22.0 L	5.8 gal

Frame

Circle		
Diameter	1553 mm	61.1 in
Height	160 mm	6.3 in
Blade Beam Thickness	40.0 mm	1.6 in
Drawbar		
Height	152 mm	6.0 in
Width	76.2 mm	3.0 in
Thickness	12.7 mm	0.50 in
Front-Top/Bottom Plate		
Width	305 mm	12.0 in
Thickness	22.0 mm	0.87 in
Front Frame Structure		
Height	321 mm	12.6 in
Width	305 mm	12.0 in
Front Axle		
Height to Center	596 mm	23.5 in
Wheel Lean, Left/Right	18°	
Total Oscillation per Side	32°	

• Front-top/bottom plate – width tolerance ± 2.5 mm (0.098 in).

Tandems

Height	572 mm	22.5 in
Width	204 mm	8.0 in
Sidewall Thickness		
Inner	17.5 mm	0.69 in
Outer	18.0 mm	0.71 in
Drive Chain Pitch	50.8 mm	2.0 in
Wheel Axle Spacing	1523 mm	60.0 in
Tandem Oscillation		
Front Up	15°	
Front Down	25°	

160/160 AWD Motor Graders Specifications

Moldboard

Blade Width	4.2 m	14 ft
Moldboard		
Height	610 mm	24.0 in
Thickness	22.0 mm	0.87 in
Arc Radius	413 mm	16.3 in
Throat Clearance	166 mm	6.5 in
Cutting Edge		
Width	152 mm	6.0 in
Thickness	16.0 mm	0.60 in
End Bit		
Width	152 mm	6.0 in
Thickness	16.0 mm	0.60 in
Blade Pull		
Base GVW	11 762 kg	25,931 lb
Maximum GVW	15 541 kg	34,262 lb
Base GVW (AWD)	16 700 kg	36,817 lb
Maximum GVW (AWD)	22 512 kg	49,630 lb
Blade Down Pressure		
Base GVW	7713 kg	17,004 lb
Maximum GVW	13 294 kg	29,308 lb
Base GVW (AWD)	8589 kg	18,935 lb
Maximum GVW (AWD)	13 294 kg	29,308 lb

Blade Range

Circle Centershift		
Right	728 mm	28.7 in
Left	695 mm	27.4 in
Moldboard Sideshift		
Right	660 mm	26.0 in
Left	510 mm	20.1 in
Maximum Blade Position Angle	90°	
Blade Tip Range		
Forward	40°	
Backward	5°	
Maximum Shoulder Reach Outside of Tires		
Right	2278 mm	89.7 in
Left	2090 mm	82.3 in
Maximum Lift Above Ground	452 mm	17.8 in
Maximum Depth of Cut	750 mm	29.5 in

Ripper

Ripping Depth, Maximum	426 mm	16.8 in
Ripper Shank Holders	5	
Ripper Shank Holder Spacing	533 mm	21.0 in
Penetration Force	9440 kg	20,812 lb
Pryout Force	12 924 kg	28,493 lb
Machine Length Increase, Beam Raised	1031 mm	40.6 in

Scarifier

Front, V-Type: Working Width	1205 mm	47.4 in
Front, V-Type, 5 or 11 Tooth		
Working Width	1031 mm	40.6 in
Scarifying Depth, Maximum	467 mm	18.4 in
Scarifier Shank Holders	5/11	
Scarifier Shank Holder Spacing	116 mm	4.6 in
Mid, V-Type		
Working Width	1184 mm	46.6 in
Scarifying Depth, Maximum	292 mm	11.5 in
Scarifier Shank Holders	11	
Scarifier Shank Holder Spacing	116 mm	4.6 in
Rear		
Working Width	2133 mm	84.0 in
Scarifying Depth, Maximum	426 mm	16.8 in
Scarifier Shank Holders	9	
Scarifier Shank Holder Spacing	267 mm	10.5 in

Weights

Gross Vehicle Weight, Base		
Total	17 563 kg	38,719 lb
Front Axle	4494 kg	9,907 lb
Rear Axle	13 069 kg	28,812 lb
Gross Vehicle Weight, Maximum		
Total	25 013 kg	55,144 lb
Front Axle	7745 kg	17,075 lb
Rear Axle	17 268 kg	38,069 lb
Operating Weight, Typically Equipped		
Total	20 660 kg	45,547 lb
Front Axle	6004 kg	13,237 lb
Rear Axle	14 656 kg	32,310 lb

160/160 AWD Motor Graders Specifications

Weights – AWD

Gross Vehicle Weight, Base		
Total	18 555 kg	40,908 lb
Front Axle	5004 kg	11,033 lb
Rear Axle	13 551 kg	29,875 lb
Gross Vehicle Weight, Maximum		
Total	25 013 kg	55,144 lb
Front Axle	7745 kg	17,075 lb
Rear Axle	17 268 kg	38,069 lb
Operating Weight, Typically Equipped		
Total	21 552 kg	47,514 lb
Front Axle	6481 kg	14,289 lb
Rear Axle	15 071 kg	33,225 lb

- Base operating weight on standard machine configuration is calculated with full fuel tank, coolant, lubricants, operator and 14.0R24 tires with multi-piece (MP) rims.
- Typically equipped operating weight is calculated with push block, transmission guard, rear ripper/scarifier, 17.5R25 tires with multi-piece (MP) rims, and other equipment.

Standards

ROPS/FOPS	ISO 3471; ISO 3499
Steering	ISO 5010
Brakes	ISO 3450
Sound	ISO 6394; ISO 6395

- The declared dynamic operator sound pressure level is 71 dB(A) for the 160 and 160 AWD when “ISO 6396:2008” is used to measure the value for a European Union “CE” marked machine. The measurement was conducted at 70% of the maximum engine cooling fan speed. The sound level may vary at different engine cooling fan speeds.
- The declared exterior sound power level is 107 dB(A) for the 160 and 108 dB(A) for the 160 AWD when the value is measured according to the dynamic test procedures and the conditions that are specified in “ISO 6395:2008.” The measurement was conducted for a European Union “CE” marked machine at 70% of the maximum engine cooling fan speed. The sound level may vary at different engine cooling fan speeds and during diesel particulate filter regeneration.

Air Conditioning System

The air conditioning system on this machine contains the fluorinated greenhouse gas refrigerant R134a (Global Warming Potential = 1430). The system contains 1.8 kg of refrigerant which has a CO₂ equivalent of 2.574 metric tonnes.

Motor Graders Specifications

Dimensions

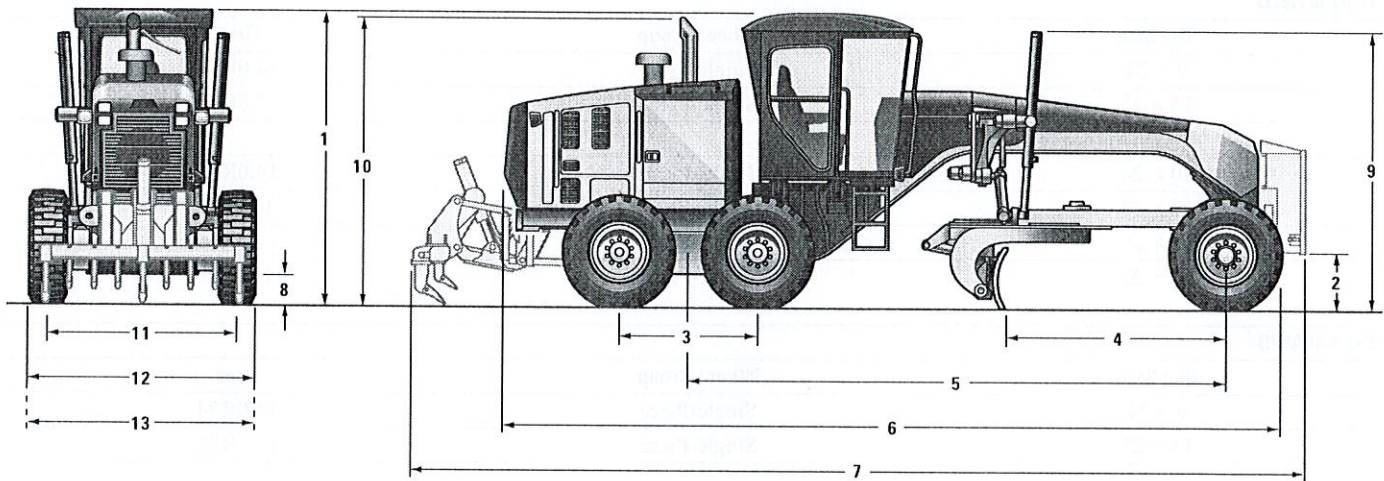

	140/140 AWD		150/150 AWD		160/160 AWD	
	mm	in	mm	in	mm	in
1 Height – Top of Cab	3308	130	3308	130	3308	130
2 Height – Front Axle Center	596	23.5	596	23.5	596	23.5
3 Length – Between Tandem Axles	1523	60.0	1523	60.0	1523	60.0
4 Length – Front Axle to Moldboard	2552	100	2552	100	2552	100
5 Length – Front Axle to Mid Tandem	6123	241	6123	241	6123	241
6 Length – Front Tire to Rear of Machine	8912	351	8912	351	8912	351
7 Length – Counterweight to Ripper	10 136	399	10 136	399	10 136	399
8 Ground Clearance at Rear Axle	339	13.3	339	13.3	339	13.3
9 Height to Top of Cylinders	3040	120	3040	120	3040	120
10 Height to Exhaust Stack	3256	128	3256	128	3256	128
11 Width – Tire Center Lines	2140	84.3	2140	84.3	2140	84.3
12 Width – Outside Rear Tires	2511	98.9	2511	98.9	2511	98.9
13 Width – Outside Front Tires	2511	98.9	2511	98.9	2511	98.9

• Calculated with 14.0R24 Tires.

Motor Graders Specifications

Optional Tire Arrangements

Common Tire Options

140/140 AWD			
Rim Size	Wheel Group	Tires	
9 × 24	Single-Piece	14.0R24	
13 × 25	Single-Piece	17.5R25	
10 × 24	Multi-Piece	14.0R24	
10 × 24	Multi-Piece	14.0-24	
14 × 25	Multi-Piece	17.5R25	
14 × 25	Multi-Piece	17.5-25	
150/150 AWD			
Rim Size	Wheel Group	Tires	
9 × 24	Single-Piece	14.0R24	
13 × 25	Single-Piece	17.5R25	
10 × 24	Multi-Piece	14.0R24	
10 × 24	Multi-Piece	14.0-24	
14 × 25	Multi-Piece	17.5R25	
14 × 25	Multi-Piece	17.5-25	
160/160 AWD			
Rim Size	Wheel Group	Tires	
9 × 24	Single-Piece	14.0R24	
13 × 25	Single-Piece	17.5R25	
10 × 24	Multi-Piece	14.0R24	
10 × 24	Multi-Piece	14.0-24	
14 × 25	Multi-Piece	17.5R25	
14 × 25	Multi-Piece	17.5-25	

Note: Consult your dealer for individual tire width, size and brand.

Standard Equipment

Standard equipment may vary. Consult your Cat dealer for details.

POWER TRAIN

- Air cleaner, dual stage, dry type, diesel, with automatic engine derate and automatic dust ejector, service indicator through Cat Messenger
- Air-to-air after cooler (ATAAC)
- Belt, serpentine, automatic tensioner
- Brakes, oil disc, four-wheel, hydraulic
- Demand fan, hydraulic, swing-out
- Diesel exhaust fluid tank, 22.0 L (5.8 gal) ground level access, and sediment drain
- Differential Lock/Unlock, Automatic
- Drain, engine oil, ecology
- Economy mode
- Electronic over speed protection
- Engine, C9.3, U.S. EPA Tier 4 Final/ EU Stage V emission standards
- Fuel tank, 394 L (104 gal), ground level access and sediment drain
- Parking brake – multi-disc, sealed, oil-cooled
- Priming pump, fuel
- Rear axle, modular
- Sediment drain, fuel tank
- Tandem drive
- Transmission, 8F/6R, powershift, direct drive, Advanced Productivity Electronic Control Strategy (APECS)

ELECTRICAL

- Alarm, back up
- Alternator, 150 ampere, sealed
- Batteries, maintenance free, heavy duty, 1125 CCA
- Breaker panel, ground accessible
- Cab harness and electrical hydraulic valves
- Electrical system, 24V
- Grade Control Ready – Cab harness, software, electrical hydraulic valves, bosses and brackets
- Lights, roof-mounted roading, reversing, LED stop and tail
- Product Link
- Starter, electric

OPERATOR ENVIRONMENT

- Accelerator
- Air conditioning with heater
- Arm and wrist rest, electronically adjustable
- Articulation, automatic Return-to-Center
- Cat Messenger operator information system
- Centershift pin indicator
- Coat hook
- Cup holder
- Display, digital speed and gear
- Doors, left and right side with wiper
- Gauge, machine level
- Gauge cluster (analog) – fuel, articulation, engine coolant temp, engine RPM, hydraulic oil temp, regen, DEF
- Hour meter, digital
- Joystick hydraulic controls right/left blade lift with float position, circle drive, blade sideshift and tip, centershift, front wheel lean, articulation and power steering
- Joystick, adjustable armrests
- Joystick gear selection
- Joystick hydraulic power steering
- Ladders, cab, left and right side
- Lights, night time cab
- Mirror, inside rearview, wide angle
- Power port, 12V
- Radio Ready, Entertainment
- ROPS cab, sound suppressed 70 dB(A)
- Seat, cloth-covered, comfort suspension
- Seat belt, retractable 76 mm (3 in)
- Storage area for cooler/lunchbox
- Throttle control, electronic
- Windows, laminated glass:
 - fixed front with intermittent wiper
 - door with intermittent wipers (3)
- Windows: tempered
 - left and right side wipers
 - rear and intermittent wiper

FLUIDS

- Antifreeze
- Extended Life Coolant to -35°C (-30°F)

TIRES, RIMS AND WHEELS

- Partial allowance for tires on 254×607 mm (10×24 in) multi-piece rims is included in the base machine price and weight

OTHER STANDARD EQUIPMENT

- Accumulators, brake, dual certified
- Anti-glare paint
- Bumper, rear, integrated with hitch
- CD ROM Parts Book
- Clutch, circle drive slip
- Cutting edges
 - 152×16 mm ($6 \times 5/8$ in)
 - curved DH-2 steel
 - 19 mm ($3/4$ in) mounting bolts
- Doors (3), engine compartment, locking
- Drawbar – 6 shoes, replaceable wear strips
- Electrical hydraulic valves, hydraulic lines for base 8 functions
- Endbits
 - 16 mm ($5/8$ in) DH-2 steel
 - 19 mm ($3/4$ in) mounting bolts
- Fluid check, ground level
- Frame, articulated, with safety lock
- Ground level engine shutdown
- Hammer (emergency exit)
- Horn, electric
- Hydraulic lines for base functions
- Lockout, hydraulic implement (for roading and servicing)
- Moldboard
- Mounting, cab roof accessories
- Pump, hydraulic, high capacity, 98 cm^3 (6 in^3)
- Radiator, cleanout access (both sides with swing doors)
- Secondary steering
- Serviceability, LH side
- S-O-SSM ports: engine, hydraulic, transmission, coolant, fuel
- Tandem walkway/guards
- Tool box

Optional Equipment

Optional Equipment

Optional equipment may vary. Consult your Cat dealer for details.

	kg*	lb*		kg*	lb*		kg*	lb*
ELECTRICAL			POWER TRAIN			WORK TOOLS/G.E.T.		
• Alternator, 280 ampere	2	5	• All Wheel Drive	892	1,967	• Blade extension, left hand, 610 mm (2 ft)	113	249
• Batteries:			• Precleaner, snow	2	5	• Blade extension, right hand, 610 mm (2 ft)	113	249
– extreme duty, 1,400 CCA	14	30	• Starter, extreme duty, 1,000 Amps	22	48	• Counterweight	427	939
• Lights:			• Transmission, autoshift	2	5	• Cutting edges, curved	43	95
– Headlights, high	38	84	OTHER ATTACHMENTS			• Endbits, overlay	24	52
– Headlights, low	35	77	• Auto Articulate			• Front lift group, mounting	5	11
– Working lights, basic	9	20	• Stable Blade			• Front lift group, mechanical	680	1,500
– Working lights, plus, LED	10	22	• Cat GRADE:			• Grader bit, narrow and super penetration	181	400
– Warning: beacon or strobe	2	5	– Digital Blade Slope Meter			• Mid-Mount Scarifier, Package	917	2,017
– Mounting for warning light	5	11	– Cross Slope Indicate			• Moldboard		
GUARDS			– Cross Slope			– 4267 mm × 610 mm × 22 mm (14 ft × 24 in × 7/8 in)	147	323
• Articulation guard	5	11	– Cat Production Measurement			– 4267 mm × 686 mm × 25 mm (14 ft × 27 in × 1 in)	284	625
• Fenders, front	121	266	• AccuGrade ARO	46	101	160/160 AWD only:	472	1,040
• Fenders, front, AWD	56	124	• Integrated cross slope	47	103	– 4877 mm × 686 mm × 25 mm (16 ft × 27 in × 1 in)		
• Fenders, rear	156	344	• Accumulators, blade lift	55	121	• Push plate	1285	2,833
• Front axle guard	13	30	• Camera, rearview	9	20	• Ripper, rear	1042	2,292
• Sound suppression (bottom)	110	243	• Cat Product Link 321SR	13	29	• Ripper tooth	28	61
• Sound suppression (enclosure)	15	33	• Cat Product Link 522	13	29	• Scarifier, front	434	956
• Transmission	141	311	• Circle Saver	4.5	10	• Snow Arrangement	161	355
OPERATOR ENVIRONMENT			• Drain, ecology, engine Wiggins	2	5	• Snow Wing Ready Package	119	262
• Mirrors, outside:			• Heater, engine coolant:			• Tow hitch	53	116
– heated 24V	15	33	– 120V	1	3	MACHINE ARRANGEMENTS		
– mounted	15	33	– 240V	1	3	• Canadian Arrangement	2	4
• Comfort Plus Arrangement	2	4	• Hydraulic arrangements with one or more additional hydraulic valves are available for rear ripper, dozer, snow plow and snow wing.			• European Arrangement	289	637
• Comfort Premium Arrangement	3	7	• Snow wing mounting, frame ready	91	200	• TUV Roding Arrangement	451	994
			• Starting aid, ether	0.5	1			
			• Reversing fan, automatic or manual	6	13			

*Weights shown are to be added to the standard configuration when option is chosen.

For more complete information on Cat products, dealer services, and industry solutions, visit us on the web at www.cat.com

© 2019 Caterpillar
All rights reserved

Materials and specifications are subject to change without notice. Featured machines in photos may include additional equipment. See your Cat dealer for available options.

CAT, CATERPILLAR, LET'S DO THE WORK, their respective logos, "Caterpillar Yellow," the "Power Edge" and Cat "Modern Hex" trade dress as well as corporate and product identity used herein, are trademarks of Caterpillar and may not be used without permission.

VisionLink is a trademark of Trimble Navigation Limited, registered in the United States and in other countries.

AEHQ7144-04 (07-2019)
Replaces AEHQ7144-03
Build Number: 15A



MOTOR GRADERS	
BID SPECIFICATION FOR 140 OR EQUIVALENT	
Bid specs are intended for use by North American buyers only and are subject to change. Model configuration may change depending on country of use. Please contact your local Caterpillar dealer for the most up-to-date specifications for your area.	
Category	Specification
BASIC SPECIFICATIONS	Machine shall be designed and built by the manufacturer.
BASIC SPECIFICATIONS	Base Machine Weight shall not be less than 31,508 lb (14,212 kg). Weight shall include: standard machine configuration, lubricants, coolants, full fuel tank and operator of 200 lbs (91 kg).
BASIC SPECIFICATIONS	Max saleable weight of the machine shall not be less than 50,420 lb (22,870 kg). Weight shall be the heaviest possible combination of compatible attachments, also including lubricants, full fuel tank and operator of 200 lbs (91 kg).
BASIC SPECIFICATIONS	Machine length from the front outside edge tire to end of tow hitch shall not be less than 334.8 in (8,504 mm).
BASIC SPECIFICATIONS	Machine Wheel Base (distance from front axle to mid tandem) shall not be less than 239.6 in (6,086 mm).
BASIC SPECIFICATIONS	Machine length from counterweight to ripper shall not exceed 394.2 in (10,013 mm).
BASIC SPECIFICATIONS	Machine height to top of the cab shall not exceed 132 in (3,354 mm).
BASIC SPECIFICATIONS	Front frame shall be a flanged box section construction which removes welds from high stress areas
BASIC SPECIFICATIONS	The rear frame shall have two box section channels with an integrated bumper.
BASIC SPECIFICATIONS	A standard rear hitch shall be provided.
ENGINE	Engine shall be designed and built by the manufacturer.
ENGINE	Engine shall be a turbo-charged, direct injection, four stroke, 6-cylinder diesel engine.
ENGINE	Engine shall be electronically controlled for more efficient fuel injection and fuel burn.
ENGINE	Engine displacement shall not be less than 7.2L (439 in ³).
ENGINE	Engine will increase its low idle speed to 1,000 rpm when the battery voltage is below 24.5 volts for more than 5 minutes to ensure adequate system voltage and battery reliability.
ENGINE	Engine shall develop a rated net flywheel power of a least 171 HP (128 kW) in 1st gear and 191 HP (143 kW) in 4th gear through 8th gear.
ENGINE	Rated engine power shall not be achieved at an engine speed greater than 2000 rpm.
ENGINE	Peak engine power shall not be achieved at an engine speed greater than 2000 rpm.
ENGINE	Engine shall be isolation/resilient mounted to minimize sound and vibration.
ENGINE	Engine shall be certified EPA Tier 3 and European Union Stage IIIa
ENGINE	Altitude deration will not occur at altitudes less than 10,000 ft (3048 m). The deration rate above 3048 m (10,000 ft) shall be 1.5% per 305 m (1000 ft).
ENGINE	Engine shall allow for at least 500 hours of operation between oil changes.
ENGINE	Engine enclosure and daily service points shall be accessible from ground level, and grouped on the left side of the machine.
ENGINE	Ether starting aid shall be available and must automatically meter ether injection to prevent engine damage.
ENGINE	Engine shall automatically lower engine torque and alert the operator if critical conditions are detected.
ENGINE	Engine compartment doors shall be lockable without the use of external locks.
ENGINE	A jacket water heater shall be available to assist in cold weather starting.
POWERTRAIN/TRANSMISSION	Transmission shall be designed and built by the machine manufacturer.
POWERTRAIN/TRANSMISSION	Transmission shall be a direct drive, power shift, countershaft type.
POWERTRAIN/TRANSMISSION	Transmission shall not have less than 8 forward speeds and 6 reverse speeds.
POWERTRAIN/TRANSMISSION	Transmission shall have 5 working gears between 0-10.8 mph (0-17.4 km/h), for dirt applications.
POWERTRAIN/TRANSMISSION	Differential Lock/Unlock shall be electro-hydraulically controlled, as a standard feature.
POWERTRAIN/TRANSMISSION	Differential Lock/Unlock shall not have speed restrictions for engaging/disengaging.
POWERTRAIN/TRANSMISSION	Differential Lock/Unlock shall be a multi-disc design.
POWERTRAIN/TRANSMISSION	Final drive shall be a planetary design.
POWERTRAIN/TRANSMISSION	A programmable auto-shift transmission option shall be available.
POWERTRAIN/TRANSMISSION	Machine shall be equipped with an electronic inching pedal for improved modulation and machine control.
POWERTRAIN/TRANSMISSION	Transmission shall be isolated/resilient mounted to reduce sound and vibration.
BRAKES	Service brakes shall be multi-disc, oil-cooled and completely sealed.
BRAKES	Service brakes shall be air actuated, utilizing dual independent brake circuits.
BRAKES	Entire braking system shall meet all requirements of ISO 3450: 1996.
BRAKES	Service brakes shall provide a minimum of 3,712 in ² (23,948 cm ²) of total friction material surface area used at each of the four tandem wheels to eliminate braking loads on the power train.
BRAKES	Parking brake shall be multi-disc, oil-cooled, air actuated and sealed
HYDRAULIC SYSTEM	Hydraulics system shall be a closed center, load sensing type, with a variable displacement, proportional priority pressure axial piston-type pump.
HYDRAULIC SYSTEM	Standard hydraulic implement pump shall produce between 0 and 20.9 gallon/min (79.0 L/min) of max oil flow.
HYDRAULIC SYSTEM	Optional high flow implement pump shall produce between 0 and 55.5 gallon/min (210.0 L/min) of max oil flow.
HYDRAULIC SYSTEM	Implement valves shall be proportional priority pressure compensating for consistent response, when multi-functioning any combination of implement controls and independent of engine speed.
HYDRAULIC SYSTEM	Hydraulic system shall be fully sealed, using Duo-cone and O-ring seals to prevent contamination and spillage.
HYDRAULIC SYSTEM	All implement hydraulic connections shall have O-ring face seals for leak prevention.
HYDRAULIC SYSTEM	Lock valves shall be integrated into the main implement valve to prevent cylinder drift.
HYDRAULIC SYSTEM	The maximum hydraulic system pressure shall be no more than 3,698.5 psi (25,500 kPa).
HYDRAULIC SYSTEM	The hydraulic stand-by pressure shall be no more than 522 psi (3600 kPa).
FRONT AXLE AND TANDEMS	Front axle shall be an arched design for maximum ground clearance.

MOTOR GRADERS	
BID SPECIFICATION FOR 140 OR EQUIVALENT	
Bid specs are intended for use by North American buyers only and are subject to change. Model configuration may change depending on country of use. Please contact your local Caterpillar dealer for the most up-to-date specifications for your area.	
Category	Specification
FRONT AXLE AND TANDEMS	Front axle oscillation shall be no less than 32 degrees total, per side 16 degrees up, 16 degrees down.
FRONT AXLE AND TANDEMS	Front wheel steering angle shall be no less than 47.5 degrees left or right.
FRONT AXLE AND TANDEMS	Front wheel spindle bearings shall be a large diameter roller bearing.
FRONT AXLE AND TANDEMS	Front wheel spindle maintenance intervals shall be no less than 2000 hrs.
FRONT AXLE AND TANDEMS	Mechanical steering stops located at each wheel and steering cylinder relief valves shall be present to prevent steering system damage during normal operation.
FRONT AXLE AND TANDEMS	Maximum front wheel lean shall be no less than 18 degrees left or right.
FRONT AXLE AND TANDEMS	Machine turning radius shall not exceed 24 ft 9 in (7.5 m) using front steering, full articulation and unlocked differential.
FRONT AXLE AND TANDEMS	Steering tie rod ends shall be heat induction hardened.
FRONT AXLE AND TANDEMS	Tandem chain pitch shall not be less than 2.0 in (50.8 mm).
FRONT AXLE AND TANDEMS	Distance between center of tandem wheels shall be no less than 60 in (1523 mm).
FRONT AXLE AND TANDEMS	Tandems shall be capable of oscillating 15 degrees front tandem up and 25 degrees front tandem down, with full machine articulation and having no interference between tandem wheel and machine structure.
OPERATORS STATION	An enclosed cab with ROPS (Rollover Protective Structure) according to ISO 3471: 1986-1997 shall be provided.
OPERATORS STATION	FOPS (Falling Object Protective Structure) shall be provided according to ISO 3449.
OPERATORS STATION	Cab shall be isolation-mounted to the front frame section of the machine.
OPERATORS STATION	Cab doors shall have a hold-open clasp with a ground-level release and in addition to, a release in the cab.
OPERATORS STATION	Cab shall have fixed front window of laminated glass with intermittent wiper.
OPERATORS STATION	Wipers shall be available on rear windows.
OPERATORS STATION	A rear sun shade shall be available.
OPERATORS STATION	A rear defroster fan shall be available.
OPERATORS STATION	Left and right side cab doors shall be standard.
OPERATORS STATION	Operator cab fresh air-filter shall be accessible for clean out and replacement, from behind the operator's seat
OPERATORS STATION	A 25,000 BTU/h (12.3 kW) heater with integral pressurizer and four-speed fan shall be standard
OPERATORS STATION	Machine shall have no less than 14 adjustable vents, positioned to direct air to front windows and operator.
OPERATORS STATION	Auxiliary controls shall be available for control of attachment implements and/or work tools
OPERATORS STATION	An instrument cluster shall be provided that includes a differential lock, throttle lock, brake air, coolant temperature, fuel and articulation angle gauge.
OPERATORS STATION	Digital machine hour meter shall be provided.
OPERATORS STATION	Seat shall be a cloth-covered suspension seat with, 3-inch (76 mm) retractable seat belts, with adjustments for fore-aft position, seat height, seat back angle, thigh support, and lumbar support.
OPERATORS STATION	Radio ready arrangement including 24V to 12V converter, two speakers, antenna and wiring shall be standard.
OPERATORS STATION	Machine shall have the AccuGrade™ system fully integrated into the machine design with integral hydraulic and electrical components as part of optional performance package with high flow implement pump
OPERATORS STATION	AccuGrade™ automatic blade control system attachment ready option shall be available from the factory. This option shall include additional mounting brackets and electrical harnesses for easy installation of the electronics kit.
DRAWBAR, CIRCLE & MOLDBOARD	Moldboard shall have a bank slope angle capability of at least 90 degrees to both sides.
DRAWBAR, CIRCLE & MOLDBOARD	There will be no more than 6 replaceable wear inserts between the circle and drawbar
DRAWBAR, CIRCLE & MOLDBOARD	Drawbar wear strips shall be replaceable drop-in inserts, made from nylon composite material.
DRAWBAR, CIRCLE & MOLDBOARD	Circle outside diameter shall be no less than 60.2 in (1530 mm).
DRAWBAR, CIRCLE & MOLDBOARD	Circle shall be a single piece, rolled-ring forging, with raised wear surfaces on the top and bottom.
DRAWBAR, CIRCLE & MOLDBOARD	Circle teeth contact surfaces shall be induction-hardened on the front 240 degrees of the circle.
DRAWBAR, CIRCLE & MOLDBOARD	Moldboard shall have a hydraulic tip control through a range of 40 degrees fore and 5 degrees aft.
DRAWBAR, CIRCLE & MOLDBOARD	The standard moldboard shall be at least 12 ft (3657 mm) long, 24 in (610 mm) high and no less than 7/8 in (22 mm) thick.
DRAWBAR, CIRCLE & MOLDBOARD	A 14 ft (4267 mm) long, 24 in (610 mm) high and no less than 7/8 in (22 mm) thick moldboard shall be available.
DRAWBAR, CIRCLE & MOLDBOARD	The standard mounting hardware for cutting edges and end bits shall be 3/4 in (19 mm)
DRAWBAR, CIRCLE & MOLDBOARD	Moldboard slide rails shall be constructed of a heat-treated, high carbon steel.
DRAWBAR, CIRCLE & MOLDBOARD	Slide rails shall be hardened and continuously welded
DRAWBAR, CIRCLE & MOLDBOARD	Throat clearance with standard moldboard shall be at least 4.7 in (120 mm).
DRAWBAR, CIRCLE & MOLDBOARD	Blade lift and center shift cylinders shall have replaceable bronze-alloy wear inserts in the ball sockets with removable shims to insure the ability to remove free play throughout the useful wear insert life.
DRAWBAR, CIRCLE & MOLDBOARD	Link bar shall have 7 positions for increased versatility.

MOTOR GRADERS	
BID SPECIFICATION FOR 140 OR EQUIVALENT	
Bid specs are intended for use by North American buyers only and are subject to change. Model configuration may change depending on country of use. Please contact your local Caterpillar dealer for the most up-to-date specifications for your area.	
Category	Specification
DRAWBAR, CIRCLE & MOLDBOARD	The moldboard retention system shall have two retention points located on the left and right side of the moldboard. The surface area shall not be less than 58016 mm ² (89.92 in ²)
DRAWBAR, CIRCLE & MOLDBOARD	The drawbar shall feature welded protective wear plates to prevent lift group contact with the primary drawbar structure.
ELECTRICAL	Machine shall have, 750 CCA heavy-duty maintenance-free batteries standard.
ELECTRICAL	Machine shall have 190 amp-hour, 1400 CCA extra heavy-duty batteries available.
ELECTRICAL	Machine shall have an 115-amp alternator as standard.
ELECTRICAL	Starting system shall be a 24V direct electric type.
ELECTRICAL	A 24 V to 12 V converter with 10-amp capacity shall be standard.
ELECTRICAL	Electrical system shall have a master disconnect switch with a removable key (in addition to the ignition switch), accessible from the ground level.
ELECTRICAL	A 24V to 12V converter with 25-amp capacity shall be available.
ELECTRICAL	White reversing lamps and red stop lamps shall be standard.
ELECTRICAL	High and low bar headlights with front turn signals shall be available.
SERVICEABILITY	A guard shall be available to protect the machine's transmission from debris.
SERVICEABILITY	A guard shall be available to suppress sound from the engine.
SERVICEABILITY	A two-way communication tool shall give service technicians easy access to stored diagnostic data and allow configuration of machine parameters.
SERVICEABILITY	Machine shall provide 3 points of contact on all areas of the machine, for mounting and dismounting.
SERVICEABILITY	The articulation joint shall have mechanical locking device to prevent frame articulation while servicing or transporting machine.
SERVICEABILITY	Left and right side tandem case assemblies shall be covered with punched steel plate to provide an adequate platform for standing and walking.
SERVICEABILITY	High-speed engine oil drain system shall be made optional
SERVICEABILITY	Sampling ports shall be accessible from the tandem level and provide access to the engine, hydraulic, coolant, and fuel ports.
MINIMUM SERVICE FILL CAPACITIES	Standard fuel tank capacity shall not be less than 86.6 gallons (305 L).
MINIMUM SERVICE FILL CAPACITIES	Standard cooling system capacity shall not be less than 10.6 gallons (40 L).
MINIMUM SERVICE FILL CAPACITIES	Standard hydraulic tank capacity shall not be less than 14.5 gallons (55 L).
MINIMUM SERVICE FILL CAPACITIES	Standard engine oil capacity shall not be less than 4.8 gallons (18 L).
MINIMUM SERVICE FILL CAPACITIES	Standard tandem housing capacity shall not be less than 16.9 gallons (64 L) each.
MINIMUM SERVICE FILL CAPACITIES	Standard front wheel spindle bearing housing shall not be less than 0.1 gallons (0.5 L).
MINIMUM SERVICE FILL CAPACITIES	Standard circle drive housing capacity shall not be less than 1.9 gallons (7 L)
SAFETY AND ENVIRONMENTAL	Machine shall have back-up lights and sounding alarm as standard when reverse gears are selected.
SAFETY AND ENVIRONMENTAL	A circle drive slip clutch shall be provided as standard, to reduce horizontal moldboard impact damage.
SAFETY AND ENVIRONMENTAL	Blade lift accumulators shall be available, to reduce vertical impact damage.
SAFETY AND ENVIRONMENTAL	An external emergency kill switch shall be available for ground level engine shut down.
SAFETY AND ENVIRONMENTAL	Electrical system shall have a master disconnect switch with a removable key and lock (in addition to the ignition switch).
SAFETY AND ENVIRONMENTAL	A guard shall be available to protect the machine's transmission from debris.
SAFETY AND ENVIRONMENTAL	Machine shall provide dual exits allowing for emergency egress should one side become obstructed
SAFETY AND ENVIRONMENTAL	Machine shall have laminated glass for the front windows and doors to protect the operator from shattered glass.
ADDITIONAL FEATURES	A rear ripper/scarifier shall be available.
ADDITIONAL FEATURES	Rear ripper shall have five ripper shank holders and 9 scarifier shank holders.
ADDITIONAL FEATURES	Rear ripper shall have a working penetration of maximum 18.2 in (462 mm) and a penetration force of at least 19,166 lb (8694 kg)
ADDITIONAL FEATURES	A front lift group shall be available
ADDITIONAL FEATURES	A front scarifier and mid-mount scarifier shall be available.
ADDITIONAL FEATURES	A snow wing frame ready option shall be available.
ADDITIONAL FEATURES	Rear fenders shall meet ISO-3457 requirements and shall not interfere with the ability to fully open any cab or engine enclosure, or service access doors.
ADDITIONAL FEATURES	An integrated communication tool providing flow of vital machine data and location shall be available. This system shall give automatic updates on machine parameters such as machine hours, machine condition, location, fault codes and alarms.
ADDITIONAL FEATURES	All core machine systems shall be electronically connected optimizing performance and preventing machine damage

Effective with sales to the first user on or after June 1, 2015

CATERPILLAR LIMITED WARRANTY

For Selected Machine Models Designated by Caterpillar with 12 Month/Unlimited Hour Warranty

Worldwide

Caterpillar Inc. or any of its subsidiaries ("Caterpillar") warrants the following products sold by it to be free from defects in material and workmanship:

- New earthmoving, construction, material handling, forestry product, paving product, compact wheel loader, mini hydraulic excavator, skid steer loader, multi terrain loader, and compact track loader machines designated by Caterpillar as having 12-months/unlimited hour warranty. See your Cat® dealer for a complete listing of covered models.

- Attachments/work tools installed on such machines prior to delivery (unless covered by the Cat Work Tool warranty statement or another manufacturer's warranty). Hammer tool points and compacting plates used on hydraulic hammers are not warranted.

An additional warranty against breakage is applicable to certain Cat ground engaging tools. An additional warranty against wear is applicable to all landfill compactor tips when used in residential waste landfills. Refer to the applicable warranty statements for coverage detail.

This warranty does not apply to:

- Cat Batteries
- Mobil-trac belts, rubber tracks used on multi terrain loaders, compact track loaders, and mini hydraulic excavators
- Cat Work Tools
- Select models designated by Caterpillar that are sold in India and China

These products are covered by other Caterpillar warranties.

This warranty is subject to the following:

Warranty Period

For new machines and work tools/attachments the warranty period is 12-months/unlimited hours, starting from date of delivery to the first user.

Note:

- For hydraulic line's quick connect/disconnect components sold on compact wheel loaders, mini hydraulic excavators, skid steer loaders, multi terrain loaders, and compact track loader machines, the warranty period is 50 hours starting from the date of delivery to the first user.
- For Draglines, Electric Rope Shovels, Hard Rock Movers, Hard Rock Feeders; the warranty period is not to exceed 24 months from shipment of the last major component from the Caterpillar place of manufacture.

Caterpillar Responsibilities

If a defect in material or workmanship is found during the warranty period, Caterpillar will, during normal working hours and at a place of business of a Cat dealer or other source approved by Caterpillar:

- Provide (at Caterpillar's choice) new, remanufactured, or Caterpillar approved repaired parts or assembled components needed to correct the defect.

Note: New, remanufactured, or Caterpillar approved replacement parts provided under the terms of this warranty are warranted for the remainder of the warranty period applicable to the product in which installed as if such parts were original components of that product. Items replaced under this warranty become the property of Caterpillar.

- Replace lubricating oil, filters, antifreeze, and other service items made unusable by the defect.
- Provide reasonable and customary labor needed to correct the defect.

User Responsibilities

The user is responsible for:

- Providing proof of delivery date to the first user.

- Labor costs, except as stated under "Caterpillar Responsibilities."
- Transportation costs, except as stated under "Caterpillar Responsibilities."
- Premium or overtime labor costs.
- Parts shipping charges in excess of those that are considered usual and customary.
- Local taxes, if applicable.
- Costs to investigate complaints, unless the problem is caused by a defect in Caterpillar material or workmanship.
- Giving timely notice of a warrantable failure and promptly making the product available for repair.
- Performance of the required maintenance (including use of proper fuel, oil, lubricants, and coolant) and items replaced due to normal wear and tear.
- Allowing Caterpillar access to all electronically stored data.

Limitations

Caterpillar is not responsible for:

- Failures resulting from any use or installation that Caterpillar judges improper.
- Failures resulting from attachments, accessory items, and parts not sold or approved by Caterpillar.
- Failures resulting from abuse, neglect, and/or improper storage or repair.
- Failures resulting from user's delay in making the product available after being notified of a potential product problem.
- Failures resulting from unauthorized repair or adjustments, and unauthorized fuel setting changes.

(Continued on the reverse side....)

This warranty covers every major component of the products. Claims under this warranty should be submitted to a place of business of a Cat dealer or other source approved by Caterpillar. For further information concerning either the location to submit claims or Caterpillar as the issuer of this warranty, write Caterpillar Inc., 100 N. E. Adams St., Peoria, IL USA 61629.

Caterpillar's obligations under this Limited Warranty are subject to, and shall not apply in contravention of, the laws, rules, regulations, directives, ordinances, orders, or statutes of the United States, or of any other applicable jurisdiction, without recourse or liability with respect to Caterpillar.

A) For products operating outside of Australia, Fiji, Nauru, New Caledonia, New Zealand, Papua New Guinea, the Solomon Islands, and Tahiti, the following is applicable:

NEITHER THE FOREGOING EXPRESS WARRANTY NOR ANY OTHER WARRANTY BY CATERPILLAR, EXPRESS OR IMPLIED, IS APPLICABLE TO ANY ITEM CATERPILLAR SELLS THAT IS WARRANTED DIRECTLY TO THE USER BY ITS MANUFACTURER.

THIS WARRANTY IS EXPRESSLY IN LIEU OF ANY OTHER WARRANTIES, EXPRESS OR IMPLIED, INCLUDING ANY WARRANTY OF MERCHANTABILITY OR FITNESS FOR A PARTICULAR PURPOSE, EXCEPT CATERPILLAR EMISSION-RELATED COMPONENTS WARRANTY FOR NEW ENGINES, WHERE APPLICABLE. REMEDIES UNDER THIS WARRANTY ARE LIMITED TO THE PROVISION OF MATERIAL AND SERVICES, AS SPECIFIED HEREIN.

CATERPILLAR IS NOT RESPONSIBLE FOR INCIDENTAL OR CONSEQUENTIAL DAMAGES.

CATERPILLAR EXCLUDES ALL LIABILITY FOR OR ARISING FROM ANY NEGLIGENCE ON ITS PART OR ON THE PART OF ANY OF ITS EMPLOYEES, AGENTS, OR REPRESENTATIVES IN RESPECT OF THE MANUFACTURE OR SUPPLY OF GOODS OR THE PROVISION OF SERVICES RELATING TO THE GOODS.

IF OTHERWISE APPLICABLE, THE VIENNA CONVENTION ON CONTRACTS FOR THE INTERNATIONAL SALE OF GOODS IS EXCLUDED IN ITS ENTIRETY.

B) For products operating in Australia, Fiji, Nauru, New Caledonia, New Zealand, Papua New Guinea, the Solomon Islands, and Tahiti, the following is applicable:

THIS WARRANTY IS IN ADDITION TO WARRANTIES AND CONDITIONS IMPLIED BY STATUTE AND OTHER STATUTORY RIGHTS AND OBLIGATIONS THAT BY ANY APPLICABLE LAW CANNOT BE EXCLUDED, RESTRICTED OR MODIFIED ("MANDATORY RIGHTS"). ALL OTHER WARRANTIES OR CONDITIONS, EXPRESS OR IMPLIED (BY STATUTE OR OTHERWISE), ARE EXCLUDED, WITHOUT LIMITING THE FOREGOING PROVISIONS OF THIS PARAGRAPH, WHERE A PRODUCT IS SUPPLIED FOR BUSINESS PURPOSES, THE CONSUMER GUARANTEES UNDER THE CONSUMER GUARANTEES ACT 1993 (NZ) WILL NOT APPLY.

NEITHER THIS WARRANTY NOR ANY OTHER CONDITION OR WARRANTY BY CATERPILLAR, EXPRESS OR IMPLIED (SUBJECT ONLY TO THE MANDATORY RIGHTS), IS APPLICABLE TO ANY ITEM CATERPILLAR SELLS THAT IS WARRANTED DIRECTLY TO THE USER BY ITS MANUFACTURER.

IF THE MANDATORY RIGHTS MAKE CATERPILLAR LIABLE IN CONNECTION WITH SERVICES OR GOODS, THEN TO THE EXTENT PERMITTED UNDER THE MANDATORY RIGHTS, THAT LIABILITY SHALL BE LIMITED AT CATERPILLAR'S OPTION TO (a) IN THE CASE OF SERVICES, THE SUPPLY OF THE SERVICES AGAIN OR THE PAYMENT OF THE COST OF HAVING THE SERVICES SUPPLIED AGAIN AND (b) IN THE CASE OF GOODS, THE REPAIR OR REPLACEMENT OF THE GOODS, THE SUPPLY OF EQUIVALENT GOODS, THE PAYMENT OF THE COST OF SUCH REPAIR OR REPLACEMENT OR THE ACQUISITION OF EQUIVALENT GOODS.

CATERPILLAR EXCLUDES ALL LIABILITY FOR OR ARISING FROM ANY NEGLIGENCE ON ITS PART OR ON THE PART OF ANY OF ITS EMPLOYEES, AGENTS OR REPRESENTATIVES IN RESPECT OF THE MANUFACTURE OR SUPPLY OF GOODS OR THE PROVISION OF SERVICES RELATING TO THE GOODS.

CATERPILLAR IS NOT LIABLE FOR INCIDENTAL OR CONSEQUENTIAL DAMAGES UNLESS IMPOSED UNDER MANDATORY RIGHTS. IF OTHERWISE APPLICABLE, THE VIENNA CONVENTION (CONTRACTS FOR THE INTERNATIONAL SALE OF GOODS) IS EXCLUDED IN ITS ENTIRETY.

C) For products supplied in Australia:

IF THE PRODUCTS TO WHICH THIS WARRANTY APPLIES ARE:

I. PRODUCTS OF A KIND ORDINARILY ACQUIRED FOR PERSONAL, DOMESTIC OR HOUSEHOLD USE OR CONSUMPTION; OR

II. PRODUCTS THAT COST AUD 40,000 OR LESS,

WHERE THOSE PRODUCTS WERE NOT ACQUIRED FOR THE PURPOSE OF RE-SUPPLY OR FOR THE PURPOSE OF USING THEM UP OR TRANSFORMING THEM IN THE COURSE OF PRODUCTION OR MANUFACTURE OR IN THE COURSE OF REPAIRING OTHER GOODS OR FIXTURES, THEN THIS SECTION C APPLIES.

THE FOLLOWING MANDATORY TEXT IS INCLUDED PURSUANT TO THE AUSTRALIAN CONSUMER LAW AND INCLUDES REFERENCES TO RIGHTS THE USER MAY HAVE AGAINST THE DIRECT SUPPLIER OF THE PRODUCTS: OUR GOODS COME WITH GUARANTEES THAT CANNOT BE EXCLUDED UNDER THE AUSTRALIAN CONSUMER LAW. YOU ARE ENTITLED TO A REPLACEMENT OR REFUND FOR A MAJOR FAILURE AND COMPENSATION FOR ANY OTHER REASONABLY FORESEEABLE LOSS OR DAMAGE. YOU ARE ALSO ENTITLED TO HAVE THE GOODS REPAIRED OR REPLACED IF THE GOODS FAIL TO BE OF ACCEPTABLE QUALITY AND THE FAILURE DOES NOT AMOUNT TO A MAJOR FAILURE. THE INCLUSION OF THIS TEXT DOES NOT CONSTITUTE ANY REPRESENTATION OR ACCEPTANCE BY CATERPILLAR OF LIABILITY TO THE USER OR ANY OTHER PERSON IN ADDITION TO THAT WHICH CATERPILLAR MAY HAVE UNDER THE AUSTRALIAN CONSUMER LAW.

TO THE EXTENT THE PRODUCTS FALL WITHIN THIS SECTION C BUT ARE NOT OF A KIND ORDINARILY ACQUIRED FOR PERSONAL, DOMESTIC OR HOUSEHOLD USE OR CONSUMPTION, CATERPILLAR LIMITS ITS LIABILITY TO THE EXTENT IT IS PERMITTED TO DO SO UNDER THE AUSTRALIAN CONSUMER LAW TO, AT ITS OPTION, THE REPAIR OR REPLACEMENT OF THE PRODUCTS, THE SUPPLY OF EQUIVALENT PRODUCTS, OR THE PAYMENT OF THE COST OF SUCH REPAIR OR REPLACEMENT OR THE ACQUISITION OF EQUIVALENT PRODUCTS.

THE WARRANTY SET OUT IN THIS DOCUMENT IS GIVEN BY CATERPILLAR INC. OR ANY OF ITS SUBSIDIARIES, 100 N. E. ADAMS ST, PEORIA, IL USA 61629, TELEPHONE 1 309 675 1000. THE USER IS RESPONSIBLE FOR ALL COSTS ASSOCIATED WITH MAKING A CLAIM UNDER THE WARRANTY SET OUT IN THIS DOCUMENT, EXCEPT AS EXPRESSLY STATED OTHERWISE IN THIS DOCUMENT, AND THE USER IS REFERRED TO THE BALANCE OF THE DOCUMENT TERMS CONCERNING CLAIM PROCEDURES, CATERPILLAR RESPONSIBILITIES AND USER RESPONSIBILITIES.

TO THE EXTENT PERMISSIBLE BY LAW, THE TERMS SET OUT IN THE REMAINDER OF THIS WARRANTY DOCUMENT (INCLUDING SECTION B) CONTINUE TO APPLY TO PRODUCTS TO WHICH THIS SECTION C APPLIES.

©2014 Caterpillar All Rights Reserved. CAT, CATERPILLAR, their respective logos, "Caterpillar Yellow," the "Power Edge" trade dress as well as corporate and product identity used herein, are trademarks of Caterpillar and may not be used without permission.

CONTROL YOUR COSTS MINIMIZE YOUR RISKS

This plan safeguards your investments in new, used and rebuilt machines beyond the standard warranty period. It includes all parts and labor to protect you against failures caused by defects in materials and workmanship. With the Powertrain Equipment Protection Plan, you can increase the predictability of service and maintenance costs—and reduce unplanned downtime.

WHAT WE DO

- Perform necessary inspections to confirm eligibility
- Install parts approved by Caterpillar on covered repairs
- Validate your enrollment in the program

WHAT YOU DO

- Operate equipment according to the Cat Operation & Maintenance Manual (OMM)
- Have recommended preventive maintenance performed at intervals specified in the OMM
- Upon request, provide proof of preventive maintenance compliance (receipts, copies of work orders, invoices)
- Promptly provide the machine for repair in the event of a covered failure

Engine - Internal Components	Camshaft & Camshaft Bearings	Hydrostatic Pumps &
Oil Cooler	Timing / Accessory Gears	Drive Motors
Manifolds	Timing Chain / Belt	Linkage / lines Connected to
Fan Motor	Inlet / Exhaust Valve	Hystat Pump
Water Pump	Valve Cover & Base	Drive (pilot / eh) Control Valves
Fuel injection Pumps	Valve Spring & Guide	Bevel and Transfer Case
Injectors	Rocker Arm	Brake and Transfer Case
Lift / Transfer Pump	Rocker Shaft Assembly	Axles
Senders / Solenoids / Sensors	Push Rod	Axle Seals
Thermostat	Balancer	Final Drive & Wheel
Flywheel & Torque Converter	Fuel Pump / Governor Drive	Final Drive Case / Bore
Engine Oil Filter Mount	Oil Pump	Final Drive Chain
Turbocharger	Oil Pan Group	Final Drive Gears
AC Compressor / Condenser	Fan & Fan Drive	Axle Shaft
Electronic Control Modules	Transmissions	Drive Axle Oil Pump
Oil Hoses / Lines (non-hydrostatic)	Hydraulic Controls	Steering
Cylinder Block	Transmission Oil Filter Base	Steering Clutch
Piston	Transmission Gears	Steering Clutch & Brake Control Valve
Piston Rings	Final Drives/Planetary	Hydraulic Systems
Piston & Connecting Rod	Drive Shafts	Hydraulic Oil Coolers
Crankshaft, Main Bearings & Rod Bearings	Transfer Case	

EXCLUSIONS

If a component is not listed, it may not be included in the plan. Other exclusions include:

- > Improper or abusive use of the machine
- > Lubricating oil, antifreeze, filters, consumables and other maintenance items replaced during the covered component repair, unless such items are rendered unusable by a covered component failure
- > Failures caused by normal wear-out
- > Freight charges for parts shipments
- > Travel time and mileage involved in getting to a job site
- > Hauling costs and / or retrieval costs
- > Overtime labor costs
- > Repair costs resulting from the failure of any non-covered components
- > Downtime loss
- > Equipment rental charges
- > Any incidental / consequential damages or costs incurred as a result of a covered component failure.
- > Modifications unless approved by Caterpillar

Examples of covered and excluded components or items are listed here. The actual dealer contract will govern. For a complete list of included components and more information on Cat Equipment Protection Plans, contact your local Cat dealer.



Click any for help

[Home](#)

[My Cases](#)

[New Case](#)

[View Cases](#)

[Search Cases](#)

[My Profile](#)

[Edit Profile](#)

[Change Password](#)

[Change Security Questions](#)

[My Company](#)

[Edit Company Profile](#)

[Add New User](#)

[View Existing Users](#)

[Close Company Account](#)

[My Reports](#)

[View Reports](#)

[My Resources](#)

[View Essential Resources](#)

[Take Tutorial](#)

[View User Manual](#)

[Contact Us](#)

Company Information

Company Name: Thompson Tractor Co., Inc.

[View / Edit](#)

Company ID Number: 47130

Doing Business As (DBA) Name:

DUNS Number:

Physical Location:

Address 1: 2401 Pinson Highway

Address 2:

City: Birmingham

State: AL

Zip Code: 35217

County: JEFFERSON

Mailing Address:

Address 1: P O. Box 10367

Address 2:

City: Birmingham

State: AL

Zip Code: 35202-0367

Additional Information:

Employer Identification Number: 630377478

Total Number of Employees: 1,000 to 2,499

Parent Organization:

Administrator:

Organization Designation:

Employer Category:

NAICS Code: 423 - MERCHANT WHOLESALERS, DURABLE GOODS

[View / Edit](#)

Total Hiring Sites: 40

[View / Edit](#)

Total Points of Contact: 3

[View / Edit](#)

[View IDIU](#)

Company ID Number: 47130

the Employer issues a tentative nonconfirmation based upon a photo non-match. The Employer will determine whether the employee contests the tentative nonconfirmation as soon as possible after the Employer receives it.

4. If the employee contests a tentative nonconfirmation issued by DHS, the Employer will provide the employee with a referral letter and instruct the employee to contact the Department through its toll-free hotline within 8 Federal Government work days.

5. If the employee contests a tentative nonconfirmation based upon a photo non-match, the Employer will provide the employee with a referral letter to DHS. DHS will electronically transmit the result of the referral to the Employer within 10 Federal Government work days of the referral unless it determines that more than 10 days is necessary.

6. The Employer agrees that if an employee contests a tentative nonconfirmation based upon a photo non-match, the Employer will send a copy of the employee's Form I-551 or Form I-766 to DHS for review by:

- Scanning and uploading the document, or
- Sending a photocopy of the document by an express mail account (furnished and paid for by DHS).

7. The Employer understands that if it cannot determine whether there is a photo match/non-match, the Employer is required to forward the employee's documentation to DHS by scanning and uploading, or by sending the document as described in the preceding paragraph, and resolving the case as specified by the Immigration Services Verifier at DHS who will determine the photo match or non-match.

ARTICLE IV

SERVICE PROVISIONS

The SSA and DHS will not charge the Employer for verification services performed under this MOU. The Employer is responsible for providing equipment needed to make inquiries. To access the E-Verify System, an Employer will need a personal computer with Internet access.

ARTICLE V

PARTIES

This MOU is effective upon the signature of all parties, and shall continue in effect for as long as the SSA and DHS conduct the E-Verify program unless modified in writing by the mutual consent of all parties, or terminated by any party upon 30 days prior written notice to the others. Any and all system enhancements to the E-Verify program by DHS or SSA, including but not limited to the E-Verify checking against additional data sources and instituting new verification procedures, will be covered under this MOU and will not cause the need for a supplemental MOU that outlines these changes. DHS agrees to train employers on all changes made to E-Verify through the use of mandatory refresher tutorials and updates to the E-Verify manual. Even

Company ID Number: 47130

**INFORMATION REQUIRED
FOR THE E-VERIFY PROGRAM**

Information relating to your Company:

Company Name: Thompson Tractor Co., Inc.

Company Facility Address: 2401 Pinson Highway
Birmingham, AL 35217

Company Alternate Address: P.O. Box 10367
Birmingham, AL 35202-0367

County or Parish: JEFFERSON

Employer Identification Number: 630377478

North American Industry
Classification Systems Code: 423

Parent Company: _____

Number of Employees: 1,000 to
2,499 Number of Sites Verified for: 5

Are you verifying for more than 1 site? If yes, please provide the number of sites verified for in each State.

- GEORGIA 5 site(s)

Information relating to the Program Administrator(s) for your Company on policy questions or operational problems:

Name: Kimberly A Stark
Telephone Number: (205) 849 - 4279 Fax Number: (205) 849 - 4565
E-mail Address: kimberlystark@thompsontractor.com

Name: Frank M Wright
Telephone Number: (205) 849 - 4267 Fax Number: (205) 849 - 4854
E-mail Address: frankwright@thompsontractor.com

**Request for Taxpayer
Identification Number and Certification**

Give form to the requester. Do not send to the IRS.

Print or type
See Specific Instructions on page 2.

Name (as shown on your income tax return) Thompson Tractor Co., Inc. DBA Thompson Power Systems, Thompson Lift Truck Co.	
Business name, if different from above and The Cat Rent Store	
Check appropriate box: <input type="checkbox"/> Individual/Sole proprietor <input checked="" type="checkbox"/> Corporation <input type="checkbox"/> Partnership <input type="checkbox"/> Limited liability company. Enter the tax classification (D=disregarded entity, C=corporation, P=partnership) ▶ <input checked="" type="checkbox"/> Exempt payee <input type="checkbox"/> Other (see instructions) ▶	
Address (number, street, and apt. or suite no.) P O Box 10367 2401 Pinson Hwy, Tarrant, AL 35217	Requester's name and address (optional)
City, state, and ZIP code Birmingham, AL 35202-0367	
List account number(s) here (optional) Lockbox Remit To: P O Box 934005, Atlanta, GA 31193-4005	

Part I Taxpayer Identification Number (TIN)

Enter your TIN in the appropriate box. The TIN provided must match the name given on Line 1 to avoid backup withholding. For individuals, this is your social security number (SSN). However, for a resident alien, sole proprietor, or disregarded entity, see the Part I Instructions on page 3. For other entities, it is your employer identification number (EIN). If you do not have a number, see *How to get a TIN* on page 3.

Note. If the account is in more than one name, see the chart on page 4 for guidelines on whose number to enter.

Social security number : : :
or
Employer identification number 63 : 0377478

Part II Certification

Under penalties of perjury, I certify that:

1. The number shown on this form is my correct taxpayer identification number (or I am waiting for a number to be issued to me), and
2. I am not subject to backup withholding because: (a) I am exempt from backup withholding, or (b) I have not been notified by the Internal Revenue Service (IRS) that I am subject to backup withholding as a result of a failure to report all interest or dividends, or (c) the IRS has notified me that I am no longer subject to backup withholding, and
3. I am a U.S. citizen or other U.S. person (defined below).

Certification Instructions. You must cross out item 2 above if you have been notified by the IRS that you are currently subject to backup withholding because you have failed to report all interest and dividends on your tax return. For real estate transactions, item 2 does not apply. For mortgage interest paid, acquisition or abandonment of secured property, cancellation of debt, contributions to an individual retirement arrangement (IRA), and generally, payments other than interest and dividends, you are not required to sign the Certification, but you must provide your correct TIN. See the Instructions on page 4.

Sign Here	Signature of U.S. person ▶ <i>Linda L. Dunbar, Controller</i>	Date ▶
------------------	---	--------

General Instructions

Section references are to the Internal Revenue Code unless otherwise noted.

Purpose of Form

A person who is required to file an information return with the IRS must obtain your correct taxpayer identification number (TIN) to report, for example, income paid to you, real estate transactions, mortgage interest you paid, acquisition or abandonment of secured property, cancellation of debt, or contributions you made to an IRA.

Use Form W-9 only if you are a U.S. person (including a resident alien), to provide your correct TIN to the person requesting it (the requester) and, when applicable, to:

1. Certify that the TIN you are giving is correct (or you are waiting for a number to be issued),
2. Certify that you are not subject to backup withholding, or
3. Claim exemption from backup withholding if you are a U.S. exempt payee. If applicable, you are also certifying that as a U.S. person, your allocable share of any partnership income from a U.S. trade or business is not subject to the withholding tax on foreign partners' share of effectively connected income.

Note. If a requester gives you a form other than Form W-9 to request your TIN, you must use the requester's form if it is substantially similar to this Form W-9.

Definition of a U.S. person. For federal tax purposes, you are considered a U.S. person if you are:

- An individual who is a U.S. citizen or U.S. resident alien,
- A partnership, corporation, company, or association created or organized in the United States or under the laws of the United States,
- An estate (other than a foreign estate), or
- A domestic trust (as defined in Regulations section 301.7701-7).

Special rules for partnerships. Partnerships that conduct a trade or business in the United States are generally required to pay a withholding tax on any foreign partners' share of income from such business. Further, in certain cases where a Form W-9 has not been received, a partnership is required to presume that a partner is a foreign person, and pay the withholding tax. Therefore, if you are a U.S. person that is a partner in a partnership conducting a trade or business in the United States, provide Form W-9 to the partnership to establish your U.S. status and avoid withholding on your share of partnership income.

The person who gives Form W-9 to the partnership for purposes of establishing its U.S. status and avoiding withholding on its allocable share of net income from the partnership conducting a trade or business in the United States is in the following cases:

- The U.S. owner of a disregarded entity and not the entity.