

BID SUBMITTAL FORM
Alabama County Joint Bid Program
Heavy Equipment – Bid Item: Heavy Duty Motor Grader-Option A

Company Name: THOMPSON TRACTOR COMPANY

Address: PO BOX 10367
BIRMINGHAM AL 35202-0367

Bid Submitted by: JAY SMITH
(Name of company representative)

Title: SALES OPERATIONS MGR E-mail address: jaysmtih@thompsontractor.com

Phone: 205-849-4242 Fax: _____

By submitting this bid, we agree:

Initials

The equipment model number identified below meets the bid specs for this bid item

JAS

That the bid price will be honored for all counties for the period from **July 1, 2026** to **December 31, 2026**.

JAS

The equipment will be delivered at the bid price to all counties participating in the joint bid program.

JAS

The company acknowledges the freight preparation and delivery price is to be included in the total bid price for the standard machine.

JAS

The company representative listed above will be the contact person for purchasing this bid item under the joint bid program.

JAS

The bid is accompanied by a current catalog or model specification document for the model number identified below.

JAS

The bid is accompanied by a copy of the manufacturer's standard warranty as required in the bid specifications.

JAS

The bid includes the E-Verify documentation required by Alabama law.

We comply with, and if awarded the contract, we will comply with, the requirements of Section 41-16-50 and Sections 41-16-160 to -166, Code of Alabama 1975.

JAS

If awarded the bid, a performance bond will be provided upon request.

JAS

The bid documents include the **Manufacturer's Suggested Retail Price Sheet (MSRP) for the Standard Machine.**

JAS

Total Bid Price for Standard Machine: \$ 372,057
(Total Bid Price for Standard Machine Includes Freight Preparation, Delivery and Standard Warranty Costs) *

Freight Preparation and Delivery: \$ 11,870
(Included in Standard Machine Bid Price)

Manufacturer's Suggested Retail Price for Standard Machine: \$ 558,429

Equipment Model #: CATERPILLAR 150

Description: MOTOR GRADER

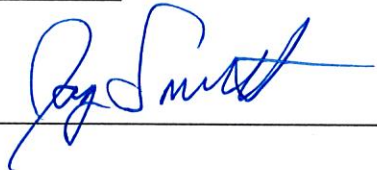
Signature of company representative submitting bid:  _____

Title: SALES OPERATIONS MANAGER

* **NOTE:** Award will be made based on the total cost of the **Standard Machine**. The total cost of the standard machine is to include freight preparation, delivery and standard warranty cost. Freight preparation and delivery will be excluded from the total bid price of the standard machine in determining the percentage discount for any available options.

BID SUBMITTAL FORM: OPTION COST SHEET

By submitting this bid, we agree:

To offer any available options at the percent difference between the Manufacturer's Suggested Retail Price Sheet and the actual bid price on the Standard Machine*



The bid documents include the **Manufacturer's Suggested Retail Price Sheet (MSRP)** for the Standard Machine



Equipment Model #: CATERPILLAR 150

Description: MOTOR GRADER

Signature of company representative submitting bid:  _____

Title: SALES OPERATIONS MANAGER

***Note:** The percent difference between the **Manufacturer's Suggested Retail Price Sheet (MSRP)** for the standard machine as specified by these **Bid Specifications** and the actual price bid by the vendor will be calculated to determine the percentage discount to be applied to any available options. The bid price of the freight preparation and delivery cost shall be excluded in determining the percentage discount to be applied to available options. Any individual county may choose to add any available option to the standard machine at the percentage discount at the time of purchase.

**BID SPECIFICATIONS
FOR
HEAVY DUTY MOTOR GRADER – OPTION A**

GENERAL

These specifications shall be construed as the minimum acceptable standards for a heavy-duty motor grader. Should the manufacturer's current published data or specifications exceed these standards, the manufacturer's standards shall be considered minimum and shall be furnished. All integral parts not specifically mentioned in the scope of these specifications that are necessary to provide a complete working unit shall be furnished. Additionally, the machine offered for bid shall include all standard manufacturer's equipment. The motor graders must be a new current production model and shall meet all EPA and other applicable standards at the time of manufacture.

The use of specific names or numbers in the specifications is not intended to restrict the bidder or any seller or manufacturer but is intended solely for the purpose of indicating the type, size, and quality of equipment considered best adapted to the uses of counties participating in this joint bid.

BID SUBMITTAL FORM

Each bidder must submit his or her bid on the Bid Submittal Form included in the invitation to bid package. All written warranties to be submitted shall be attached to the Bid Submittal Form.

BID PRICE

The price bid shall include all destination charges, delivery charges, title fees, rebates and all other applicable costs and refunds.

MANUALS

Each unit shall be provided with one (1) copy of the operator's manual, one (1) copy of the repair manual and one (1) copy of the current parts manual. Units will not be accepted for delivery until the manuals as outlined above are received by the purchaser.

REPLACEMENT PARTS AVAILABILITY

Parts must be available for 5 years or 7,500 hours of use for the piece of equipment bid. If replacement parts are not delivered within three (3) working days of an order being placed, the bidder will deliver an equivalent machine for the County to use at no cost to the County until such time as the parts are delivered to the County so it can affect repairs to its machine.

WARRANTY

Bidders shall submit a copy of the manufacturer's standard warranty. Warranty shall include service response time of a maximum of 36 hours within notification by county.

Yes No
Page # _____
or
Attachment

ENGINE

Engine shall be a turbo-charged, direct injection, four-stroke, **6-cylinder** diesel engine and shall be electronically controlled for more efficient fuel injection and fuel burn.

Engine Shall be designed and manufactured by the machine manufacturer.

Yes No
Page # 1, 6, 23

Engine displacement shall not be less than **567 cu. in.** and shall develop, as standard, a rated net power of at least **200 HP** in 1st gear,

210 HP in 2nd gear, **220 HP** in 3rd gear,

231 HP in 4th gear, **236 HP** in 5th gear,

241 HP in 6th gear, **247 HP** in 7th gear

and **252 HP** in 8th gear.

Yes No
Page # 23

Engine shall be isolation/resilient mounted to minimize sound and vibration and shall meet currently required EPA emission regulations for manufacturer.

Yes No
Page # 6, 10, 23

Engine compartment enclosure doors shall be lockable without the use of external locks and accessible from the ground. All daily service points shall be accessible from ground level and grouped together.

Yes No
Page # 14, 17, 33
Bid Spec p-2

Engine will increase its low idle to **1,000 rpm** when the battery voltage is below **24.5 volts** for more than **5 minutes** to ensure adequate system voltage and battery reliability.

Yes No
Page # 17, Bid Spec p.1

STARTING SYSTEM

Shall be equipped with a **24-volt** electrical system. **100-amp** alternator.

Yes No
Page # 33

TRANSMISSION-8 Forward Speeds and 6 Reverse Speeds

Shall be designed and built by the machine manufacturer and shall be a direct drive, power shift, counter-shaft type transmission.

Yes No
Page # 8, 11, 23

Shall be equipped with built-in self-diagnostic capability

Yes No
Page # 17

A controlled throttle shifting system shall be standard to smooth directional gear changes without use of the inching pedal.

Yes No
Page # 8

Electronic Throttle Control (cruise control) shall be standard and shall be controlled by a push button, located on a **3-axis** joystick as standard on the right joystick control for resuming and decreasing throttle set.

Yes No
Page # 5, 33

Direction control shall be a **3-position** rocker switch for selecting forward, neutral, and reverse, while gear selection shall be controlled by dual push-buttons for up-shifting and down-shifting, both of which shall be incorporated into a single, **3-axis**, multi-function, left-hand joystick control.

Yes No
Page # 5, Bid Spec
P. 5

Differential Lock/Unlock shall be electro-hydraulically controlled, via a push-button, located on a single **3-axis**, multi-function, right-hand joystick control.

Yes No
Page # Bid Spec P. 3

Final drive shall be a planetary design.

Yes No
Page # Bid Spec P. 2

Machine shall be equipped with an electronic inching pedal for improved modulation and machine control, and with electronic over-speed protection to protect the engine and transmission from over speeding.

Yes No
Page # Bid Spec P. 2

Also, to be equipped with transmission guard.

Yes No
Page # 26

TANDEM

Machine to be equipped with differential lock/unlock electro-hydraulically controlled with a multi-disc design.

Yes No
Page # 6, 23, 24
Bid Spec P. 2

Tandems shall be capable of oscillating **15 degrees** front tandem up and **25 degrees** front tandem down, with full machine articulation and having no interference between tandem wheel and machine structure

Yes No
Page # 23, 24

CONTROLS AND HYDRAULICS

Hydraulics system shall be a closed center, load sensing type, with a variable Displacement, axial piston-type pump.

Yes No
Page # 10, Bid Spec P. 3

Implement valves shall be electro-hydraulic, designed and built by the machine manufacturer.

Yes No
Page # 5, 10, Bid Spec
P. 3

Lock valves shall be integrated into the main implement valve to prevent cylinder drift.

Yes No
Page # Bid Spec P. 3

Blade lift cylinders shall have independent float capability, actuated by two, multi-functioning, **3-axis** joystick controls and auxiliary controls inside the cab.

Yes No
Page # 10, Bid Spec
P. 3

Hydraulic controls shall be joystick actuated.

Yes No
Page # 5, 33

BLADES

Machine shall be equipped with **14 ft. long, 24 in** high and no less than **7/8** in thick moldboard with hydraulic side shift and tip control.

Yes No
Page # 16, 150 PRICE PAGE

Blade shall also include reversible overlay end bits.

Yes No
Page # 34

All blade functions shall be hydraulically or electronically actuated.

Yes No
Page # 9, 10

Blade lift accumulators shall be available, to reduce vertical impact damage.

Yes No
Page # 15, 32, 34

DRAWBAR AND CIRCLE

Circle shall be a single piece, rolled-ring forging with raised wearing surface top and bottom

Yes No
Page # BID SPEC. 2

Must be equipped with replaceable wear strips between circle and support shoes.

Yes No
Page # 9, 33

Rear drawbar shall be equipped with slip clutch designed to protect the circle, drawbar, and moldboard from shock when end of blade encounters, hidden objects.

Yes No
Page # 15

Drawbar shall feature welded protective wear plates to prevent lift group contact with the primary drawbar structure.

Yes No
Page # BID SPEC. 2

The circle shall be steel construction with 6 replaceable wear shoes.

Yes No
Page # 33, BID SPEC. P. 2

FRAME

Articulated type main frame.

Yes No
Page # 33

Articulation joint shall have mechanical locking device to prevent frame articulation while servicing or transporting machine.

Yes No
Page # 33

Shall be that of a flanged box section type frame that runs from the front bolster to the articulation joints.

Yes No
Page # 9

STEERING

Fully hydraulic, **2-cylinder** steering system, with front steering wheel angle not less than **47.5°** left or right.

Yes No
Page # 12, BID SPEC. P. 2

Machine, drawbar, circle, and moldboard shall be controlled with a maximum of two multifunction, **3-axis**, joysticks, as standard.

Yes No
Page # 4, 33
BID SPEC P. 2

Joystick controls shall be mounted to adjustable pedestals, hard mounted to the cab floor, independent of the operator seat.

Yes No
Page # 5, 6, 7, 8, 9, 10, 11, 12, 13, 14, 15, 16, 17, 18, 19, 20, 21, 22, 23, 24, 25, 26, 27, 28, 29, 30, 31, 32, 33, 34, 35, 36, 37, 38, 39, 40, 41, 42, 43, 44, 45, 46, 47, 48, 49, 50, 51, 52, 53, 54, 55, 56, 57, 58, 59, 60, 61, 62, 63, 64, 65, 66, 67, 68, 69, 70, 71, 72, 73, 74, 75, 76, 77, 78, 79, 80, 81, 82, 83, 84, 85, 86, 87, 88, 89, 90, 91, 92, 93, 94, 95, 96, 97, 98, 99, 100 Spec p. 3

Joystick Steering capabilities shall be ISO 5010:1992

Yes No
Page # 26

Primary steering shall be achieved via a left-hand joystick, using an intuitive steering control system.

Yes No
Page # 81, 82, 83, 84, 85, 86, 87, 88, 89, 90, 91, 92, 93, 94, 95, 96, 97, 98, 99, 100 Spec p. 1

Secondary steering shall be a standard feature.

Yes No
Page # 15, 23

TIRES

All six wheels shall be **10 in by 24 in size** multi-piece tire rims and shall provide mounting for **14.00 R24** tires.

Yes No
Page # 32

Tires shall be Goodyear, Bridgestone/Firestone, or Michelin only, **14.00 x R24 12PR** Bias Tires.

Yes No
Page # 150 tire options

BRAKES

Service brakes shall be multi-disc, oil-cooled and completely sealed.

Yes No
Page # 8

OIL ANALYSIS

To be included at no cost of the duration of the warranty period selected at intervals recommended by the manufacturer's warranty and maintenance schedule.

Yes No
Page #

WEIGHT (STANDARD OPERATING)

Base machine weight shall not be less than **38,190 lbs.** Weight shall include standard machine configuration, lubricants, coolants, full fuel tank and operator of **200lbs** This is factory specified operating weight only. No additional weights may be added for purpose of meeting these specifications.

Yes No
Page # 4, 25, 26

150 HEAVY DUTY MOTOR GRAD A

150	HEAVY DUTY MOTOR GRADER A	2026 Pricing
548-8074	150 MOTOR GRADER	\$517,007
680-0909	REGIONAL PACKAGE JOYSTICK	\$0
243-6704	14' PLUS MOLDBOARD	\$2,662
	BLADE, 14' X 27" X 1"	\$0
233-7143	14' CUTTING EDGE	\$376
233-7160	OVERLAY END BITS	\$479
651-1837	TOP ADJUST DRAWBAR	\$0
650-3412	COLD WEATHER PACKAGE (ETHER STARTING AID)	\$984
626-4219	BLADE LIFT ACCUMULATORS	\$6,069
648-7316	GRAVITY ENGINE OIL DRAIN	\$0
650-3417	BASE 10 HYDRAULICS	\$0
648-7308	HEAVY DUTY ELECTRIC STARTER	\$0
648-7312	150 AMP ALTERNATOR	\$0
585-6621	JUMP START RECEPTACLE	\$0
599-0265	FOLD DOWN LIGHTS	\$1,775
626-8101	NO WORK LIGHTS	\$0
626-6868	REAR PLUS TURN LIGHTS	\$1,617
626-1559	WARNING LIGHT MOUNTING	\$944
626-1521	CAB PLUS: (STANDARD GLASS)	\$1,435
506-2611	STANDARD SEAT	\$2,637
594-6360	SEAT BELT W/ INDICATOR	\$0
626-8054	REAR VISION CAMERA	\$2,188
466-1323	OUTSIDE MOUNTED MIRRORS	\$638
626-1552	RADIO W/ BLUETOOTH	\$755
626-6846	PRODUCT LINK, CELLULAR PLE643/743	\$0
676-0280	CAT GRADE W/ CROSS SLOPE	\$0
594-9610	SWING OUT FAN	\$0
650-3391	R134A REFRIGERANT	\$0
680-9068	COOLANT -40C	\$0
252-0679	14.0R24 MX XGLA2 * G2 MICHELIN TIRES	\$13,025
	RADIAL TIRES WITH MULTI-PIECE RIMS	\$0
607-7305	TOWING HITCH	\$709
594-3135	JOYSTICK DECALS	\$0
548-5882	GP FILM	\$0
421-8926	SERIALIZED MEDIA KIT	\$0
610-2053	TRANSMISSION GUARD	\$4,427
580-0241	ADDITIONAL REAR STEP	\$392
521-3250	CIRCLE GREASER	\$311
0P-2918	STORAGE PROTECTION	\$0
0P-2265	ROLL ON - ROLL OFF	\$0
	TOTAL BID PRICE FOR STANDARD MACHINE	\$372,057
	FREIGHT PREPARATION AND DELIVERY	\$11,870
	TOTAL MANUFACTURER'S SUGGESTED RETAIL PRICE FOR STANDARD MACHINE	\$558,429

USE	REF NO.	LANE 2 / 3 MANDATORY	Ship Weight lbs	LIST PRICE AT DEALER
-----	---------	----------------------	-----------------	----------------------

LANE SELECTION

LANE SELECTION

OP-9002	LANE 2 ORDER	0	NC
	Only for dealers enrolled in the Base Orders Management (BOM) program.		
OP-9003	LANE 3 ORDER	0	NC

REGIONAL PACKAGES

REGIONAL PACKAGES

L	680-0909	REGIONAL PACKAGE, GENERAL JOY	0	NC
---	----------	-------------------------------	---	----

PERFORMANCE PACKAGES

MOLDBOARD PACKAGES

L	243-6702	MOLDBOARD, 12'	0	NC
		Moldboard 12- x 24- x 7/8- (3658 x 610 x 22mm) with hydraulic side shift		
L	243-6703	MOLDBOARD, 14' BASIC	166	
		Moldboard 14- x 25- x 7/8- (4267 x 635 x 22mm) with hydraulic side shift		
L	243-6704	MOLDBOARD, 14' PLUS	460	
		Moldboard 14- x 27- x 1- (4267 x 686 x 25mm) with hydraulic side shift		

CUTTING EDGE & GRADER BITS

L	233-7139	CUTTING EDGE, 12' BLADE	44	NC
		6" x 5/8" (152 x 16 mm) curved cutting edge. ONLY FOR USE WITH: 243-6702 MOLDBOARD, 3.7M		
L	233-7143	CUTTING EDGE, 14' BLADE	55	
		8- x 3/4" (203 x 19 mm) curved cutting edge ONLY FOR USE WITH: 243-6703 MOLDBOARD, 4.3M BASIC 243-6704 MOLDBOARD, 4.3M PLUS		
L	646-1355	GRADERBIT2 STANDARD BIT 14	0	
		For use in Lane 3 only Serrated edge with 70 replaceable carbide tipped narrow bits with a tool-less retention system. ONLY FOR USE WITH: 243-6703 MOLDBOARD, 4.3M BASIC 243-6704 MOLDBOARD, 4.3M PLUS		
L	646-1531	GRADERBIT2 WIDE BIT 14	0	
		For use in Lane 3 only Straight edge with 70 replaceable carbide tipped wide bits with a tool-less retention system. ONLY FOR USE WITH: 243-6703 MOLDBOARD, 4.3M BASIC 243-6704 MOLDBOARD, 4.3M PLUS		

END BIT & OVERLAY

L	233-7148	END BITS, STANDARD	0	NC
		Moldboard end bits, standard, without overlay.		

USE	REF NO.	LANE 2 / 3 MANDATORY	Ship Weight lbs	LIST PRICE AT DEALER
-----	---------	----------------------	-----------------	----------------------

PERFORMANCE PACKAGES (CONT.)

END BIT & OVERLAY (Cont.)

L	233-7160	END BITS, OVERLAY	52	
		Moldboard end cutting bit with a reversible overlay to protect the moldboard and cutting edge.		
		ONLY FOR USE WITH: 233-7143 CUTTING EDGE, 4.3M BLADE		
		CANNOT BE USED WITH: 233-7139 CUTTING EDGE		
		646-1355 GRADERBIT2 STANDARD BIT 14'		
		646-1531 GRADERBIT2 WIDE BIT 14'		

DRAWBAR ARRANGEMENT

L	651-4003	DRAWBAR, HPC	0	
		Caterpillar High Performance Circle replaces circle shoes and wear strips with a roller bearing. System eliminates need for circle adjustment and reduces maintenance. Ideal for customers in application with high wear rate of circle strips, or applications where maintaining circle tightness without adjustment for precise finish grading is required. Includes top mounted nested greasebank for ease of greasing and reinforced circle for durability. Setscrew moldboard wear strip adjustment.		
		ONLY FOR USE WITH: 676-0283 CAT GRADE, CROSS SLOPE, HPC or 676-0285 CAT GRADE, 3D MASTLESS, HPC or 676-0286 CAT GRADE, 3D READY, HPC		
L	651-1837	DRAWBAR, TOP ADJUST	0	NC
		Top Adjust Drawbar and Circle. Top-adjust circle wear strips. Setscrew moldboard wear strip adjustment. Adjustment allows for DCM assembly to keep tighter grades. Ideal for customers who perform finish grading work and frequently maintain their drawbar, circle and moldboard for factory tightness		
		ONLY FOR USE WITH: 676-0280 CAT GRADE, CROSS SLOPE, TOP AD or 676-0281 CAT GRADE, 3D MASTLESS, TOP AD or 676-0282 CAT GRADE, 3D READY, TOP AD		

WEATHER PACKAGES

L	548-8060	WEATHER, STANDARD	0	NC
		Recommended for year around use when typical ambient temperature range is 0C (32F) to 43C (110F) and operating at altitude below 1220 m (4000 feet). Includes 10W Hydraulic Oil and 1125 CCA battery.		
L	548-8031	WEATHER, STANDARD, AWD	0	NC
		Recommended for year around use when typical ambient temperature range is 0C (32F) to 43C (110F) and operating at altitude below 1220 m (4000 feet). Includes 10W Hydraulic Oil and 1125 CCA battery.		
L	650-3412	COLD WEATHER PACKAGE	0	
		Recommended for year around use when typical ambient temperature range is -18C (0F) to 43C (110F) and operating at altitude below 1220 m (4000 feet). INCLUDES: - Starting Aid, Ether - Batteries, Extreme Duty -1400 CCA - Oil, Hydraulic, 10W		

USE	REF NO.	LANE 2 / 3 MANDATORY	Ship Weight lbs	LIST PRICE AT DEALER
-----	---------	----------------------	-----------------	----------------------

TIRES, RIMS, AND WHEELS

TIRES

**To calculate tire loads with machine attachments, please reference the MG Tire Selection Pocket Guide (media #AEXQ0403),

Available on the Electronic Sales Library.
 All tire selections should be made with consideration for planned machine attachments (OEM and aftermarket) and their additional weight. Each tire has a maximum load rating that is not to be exceeded. The tire selection should be based on the maximum of all tire position loads on the machine. Assistance for calculating the highest tire load can be found in the Tire Load Worksheet in the back of the Caterpillar Motor Graders Tire Selection Pocket Guide. Failure to abide by the load ratings of the tires without first consulting the local tire supplier representative could result in nullification of the tire warranty

TIRES (TND)

MICHELIN

L	252-0679	TIRES, 14.0R24 MX XGLA2 * G2 MP 1,069 Michelin XGLA2 1* on 10" x 24" multi-piece rims. THE TIRE MANUFACTURER DOES NOT RECOMMEND THIS TIRE FOR INDIVIDUAL TIRE LOADS EXCEEDING (7824 lbs) 3550 kg.** This tire delivers excellent traction with an aggressive, non-directional tread. The large contact patch improves handling and stability over a wide range of underfoot conditions.
L	252-0701	TIRES, 14.0 R24 MX XSNO+ * G2 MP 1,282 SUITABLE FOR SNOW Michelin XSNO 1* on 10" x 24" multi-piece rims. THE TIRE MANUFACTURER DOES NOT RECOMMEND THIS TIRE FOR INDIVIDUAL TIRE LOADS EXCEEDING (7824 lbs) 3550 kg.** Designed for all season use with a reduced operating cost. Provides excellent traction on snow and ice. This tire is suitable for all season applications, providing smooth and comfortable operation.
L	252-0771	TIRES, 17.5R25 MX XTLA * L2 MP 1,371 Michelin XTLA 1* on 14" x 25" multi-piece rims. THE TIRE MANUFACTURER DOES NOT RECOMMEND THIS TIRE FOR INDIVIDUAL TIRE LOADS EXCEEDING (8045 lbs) 3650 kg.** This tire will give exceptional traction and long, even treadwear. The reinforced crown of the tire provides increased stability in a wide variety of applications and conditions.
L	252-0777	TIRES, 17.5R25 MX XSNO+ * G2 MP 1,093 SUITABLE FOR SNOW Michelin XSNO+ 1* on 14" x 25" multi-piece rims. THE TIRE MANUFACTURER DOES NOT RECOMMEND THIS TIRE FOR INDIVIDUAL TIRE LOADS EXCEEDING (8045 lbs) 3650 kg.** Designed for all season use with a reduced operating cost. Provides excellent traction on snow and ice. This tire is suitable for all season applications, providing smooth and comfortable operation.

USE	REF NO.	LANE 2 / 3 MANDATORY	Ship Weight lbs	LIST PRICE AT DEALER
-----	---------	----------------------	-----------------	----------------------

TIRES, RIMS, AND WHEELS (CONT.)

BRIDGESTONE

L	648-0073	TIRES, 14.0R24 BS VSWAS G2 MP 0 Bridgestone VSWAS 1* on 10" x 24" multi-piece rims. THE TIRE MANUFACTURER DOES NOT RECOMMEND THIS TIRE FOR INDIVIDUAL TIRE LOADS EXCEEDING (8045 lbs) 3650 kg.** This tire is an all-steel radial tire that provide excellent traction in snow dirt and mud. This tire is also suitable for summer use.		
L	252-0714	TIRES, 14.0 R24 BS VKT * G2 MP 1, 540 Bridgestone VKT 1* on 10" x 24" multi-piece rims. THE TIRE MANUFACTURER DOES NOT RECOMMEND THIS TIRE FOR INDIVIDUAL TIRE LOADS EXCEEDING 3650 kg (8,045 lbs).** Ideal for heavy duty applications, this tire is built to provide long even wear, flotation and traction all while delivering a smooth vibration free ride		
L	252-0775	TIRES, 17.5R25 BS VKT * D2A MP 1, 810 Bridgestone VKT 1* on 14" x 25" multi-piece rims. THE TIRE MANUFACTURER DOES NOT RECOMMEND THIS TIRE FOR INDIVIDUAL TIRE LOADS EXCEEDING (8045 lbs) 3650 kg.** Ideal for heavy duty applications, this tire is built to provide long even wear, flotation and traction all while delivering a smooth vibration free ride		
L	648-0075	TIRES, 17.5R25 BS VSWAS G2 MP 0 Bridgestone VSWAS 1* on 14" x 25" multi-piece rims. THE TIRE MANUFACTURER DOES NOT RECOMMEND THIS TIRE FOR INDIVIDUAL TIRE LOADS EXCEEDING (8045 lbs) 3650 kg.** This tire is an all-steel radial tire that provide excellent traction in snow dirt and mud. This tire is also suitable for summer use.		

MAXAM

L	578-9460	TIRES 14.00R24 MA MS202 * MP 0 Maxam MS202 2* on 10 x 24 multi-piece rims. THE TIRE MANUFACTURER DOES NOT RECOMMEND THIS TIRE FOR INDIVIDUAL TIRE LOADS EXCEEDING (8600 lbs) 3650kg.* Non-directional pattern designed to maximize traction in soft and rocky conditions. Provides excellent traction in mud, snow and ice while giving a smooth ride and cut resistance.		
L	578-9458	TIRES 17.5R25 MA MS202 ** MP 0 Maxam MS202 2* on 14- x 25- multi-piece rims. THE TIRE MANUFACTURER DOES NOT RECOMMEND THIS TIRE FOR INDIVIDUAL TIRE LOADS EXCEEDING (8600 lbs) 3900kg.* Non-directional pattern designed to maximize traction in soft and rocky conditions. Provides excellent traction in mud, snow and ice while giving a smooth ride and cut resistance.		

SOIL TRACTION

L	515-5399	TIRES, 14.0R24 SOIL TRACTION MP 0 Tire group received will be one of the tire groups listed below: - Bridgestone VKT 1* on 10" x 24" multi-piece rims. - Michelin XGLA2 1* on 10" x 24" multi-piece rims. THE TIRE MANUFACTURER DOES NOT RECOMMEND THIS TIRE FOR INDIVIDUAL TIRE LOADS EXCEEDING (8045 lbs) 3650 kg.**		
---	----------	--	--	--

USE	REF NO.	LANE 2 / 3 MANDATORY	Ship Weight lbs	LIST PRICE AT DEALER
-----	---------	----------------------	-----------------	----------------------

TIRES, RIMS, AND WHEELS (CONT.)

SOIL TRACTION (Cont.)

L 515-5400 TIRES, 17.5R25 SOIL TRACTION MP 0
 Tire group received will be one of the tire groups listed below:
 - Bridgestone VKT 1* on 14" x 25" multi-piece rims.
 - Michelin XTLA 1* on 14" x 25" multi-piece rims.
 THE TIRE MANUFACTURER DOES NOT RECOMMEND THIS TIRE FOR INDIVIDUAL TIRE LOADS EXCEEDING (8045 lbs) 3650 kg.**

TIRES (AWD)

MICHELIN

L 249-7845 TIRES, 14.0R24 MX XSNO + * G2 MP 1,261
 Michelin XSNO 1* on 10" x 24" multi-piece rims.
 THE TIRE MANUFACTURER DOES NOT RECOMMEND THIS TIRE FOR INDIVIDUAL TIRE LOADS EXCEEDING (7824 lbs) 3550 kg.**
 Designed for all season use with a reduced operating cost. Provides excellent traction on snow and ice. This tire is suitable for all season applications, providing smooth and comfortable operation.

L 252-0681 TIRES, 14.0R24 MX XGLA2 * G2 MP 1,048
 Michelin XGLA2 1* on 10" x 24" multi-piece rims.
 THE TIRE MANUFACTURER DOES NOT RECOMMEND THIS TIRE FOR INDIVIDUAL TIRE LOADS EXCEEDING (7824 lbs) 3550 kg.**
 This tire delivers excellent traction with an aggressive, non-directional tread. The large contact patch improves handling and stability over a wide range of underfoot conditions.

L 252-0773 TIRES, 17.5R25 MX XTLA * L2 MP 268
 Michelin XTLA 1* on 14" x 25" multi-piece rims.
 THE TIRE MANUFACTURER DOES NOT RECOMMEND THIS TIRE FOR INDIVIDUAL TIRE LOADS EXCEEDING (8045 lbs) 3650 kg.**
 This tire will give exceptional traction and long, even treadwear. The reinforced crown of the tire provides increased stability in a wide variety of applications and conditions.

L 252-0779 TIRES, 17.5R25 MX XSNO + * G2 MP 903
 Michelin XSNO+ 1* on 14" x 25" multi-piece rims.
 THE TIRE MANUFACTURER DOES NOT RECOMMEND THIS TIRE FOR INDIVIDUAL TIRE LOADS EXCEEDING (8045 lbs) 3650 kg.**
 Designed for all season use with a reduced operating cost. Provides excellent traction on snow and ice. This tire is suitable for all season applications, providing smooth and comfortable operation.

BRIDGESTONE

L 648-0078 TIRES, 14.0R24 BS VSWAS G2 MP 0
 Bridgestone VSWAS 1* on 10" x 24" multi-piece rims.
 THE TIRE MANUFACTURER DOES NOT RECOMMEND THIS TIRE FOR INDIVIDUAL TIRE LOADS EXCEEDING (8045 lbs) 3650 kg.**
 This tire will give exceptional traction and long, even treadwear. The reinforced crown of the tire provides increased stability in a wide variety of applications and conditions.

USE	REF NO.	LANE 2 / 3 MANDATORY	Ship Weight lbs	LIST PRICE AT DEALER
-----	---------	----------------------	-----------------	----------------------

TIRES, RIMS, AND WHEELS (CONT.)

BRIDGESTONE (Cont.)

L	252-0716	TIRES, 14.0R24 BS VKT * G2 MP 1,519 Bridgestone VKT 1* on 10" x 24" multi-piece rims. THE TIRE MANUFACTURER DOES NOT RECOMMEND THIS TIRE FOR INDIVIDUAL TIRE LOADS EXCEEDING (8045 lbs) 3650 kg.** Ideal for heavy duty applications, this tire is built to provide long even wear, flotation and traction all while delivering a smooth vibration free ride		
L	249-7841	TIRES, 17.5R25 BS VKT * D2A MP 1,620 Bridgestone VKT 1* on 14" x 25" multi-piece rims. THE TIRE MANUFACTURER DOES NOT RECOMMEND THIS TIRE FOR INDIVIDUAL TIRE LOADS EXCEEDING (8045 lbs) 3650 kg.** Ideal for heavy duty applications, this tire is built to provide long even wear, flotation and traction all while delivering a smooth vibration free ride		
L	648-0080	TIRES, 17.5R25 BS VSWAS G2 MP 0 Bridgestone VSWAS 1* on 14" x 25" multi-piece rims. THE TIRE MANUFACTURER DOES NOT RECOMMEND THIS TIRE FOR INDIVIDUAL TIRE LOADS EXCEEDING (8045 lbs) 3650 kg.** This tire is an all-steel radial tire that provide excellent traction in snow dirt and mud. This tire is also suitable for summer use.		
L	600-4199	TIRES, 550/65R25 BS VTS *L3 MP 0 For availability please contact facility before placing the order Offers optimum traction and low ground pressure for fine grading applications. Bridgestone VTS 1* on 14" x 25" multi-piece rims. THE TIRE MANUFACTURER DOES NOT RECOMMEND THIS TIRE FOR INDIVIDUAL TIRE LOADS EXCEEDING (8045 lbs) 3650 kg.** Tire features a low profile design that rejects stones and optimizes operator comfort while providing excellent traction and stability in quarry, and construction applications.		

MAXAM

L	578-9463	TIRES 14.00R24 MA MS202 * MP 0 Maxam MS202 1* on 10- x 24- multi-piece rims. THE TIRE MANUFACTURER DOES NOT RECOMMEND THIS TIRE FOR INDIVIDUAL TIRE LOADS EXCEEDING (8377 lbs) 3800kg.** Non-directional pattern designed to maximize traction in soft and rocky conditions. Provides excellent traction in mud, snow and ice while giving a smooth ride and cut resistance.		
L	578-9462	TIRES 17.5R25 MA MS202 ** MP 0 Maxam MS202 2* on 14- x 25- multi-piece rims. THE TIRE MANUFACTURER DOES NOT RECOMMEND THIS TIRE FOR INDIVIDUAL TIRE LOADS EXCEEDING (8600 lbs) 3900kg.** Non-directional pattern designed to maximize traction in soft and rocky conditions. Provides excellent traction in mud, snow and ice while giving a smooth ride and cut resistance.		

USE	REF NO.	LANE 2 / 3 MANDATORY	Ship Weight lbs	LIST PRICE AT DEALER
-----	---------	----------------------	-----------------	----------------------

TIRES, RIMS, AND WHEELS (CONT.)

SOIL TRACTION

L	515-5404	TIRES, 14.0R24 SOIL TRACTION MP 0 Tire group received will be one of the tire groups listed below: - Bridgestone VKT 1* on 10" x 24" multi-piece rims. - Michelin XGLA2 1* on 10" x 24" multi-piece rims. THE TIRE MANUFACTURER DOES NOT RECOMMEND THIS TIRE FOR INDIVIDUAL TIRE LOADS EXCEEDING (8045 lbs) 3650 kg.**		
L	515-5405	TIRES, 17.5R25 SOIL TRACTION MP 0 Tire group received will be one of the tire groups listed below: - Bridgestone VKT 1* on 14" x 25" multi-piece rims. - Michelin XTLA 1* on 14" x 25" multi-piece rims. THE TIRE MANUFACTURER DOES NOT RECOMMEND THIS TIRE FOR INDIVIDUAL TIRE LOADS EXCEEDING (8045 lbs) 3650 kg.**		

WORK TOOLS

REAR WORK TOOLS

L	585-4527	NO HITCH 0 Provides a plate that bolts to the bumper that allows for attachment points for ripper or auxiliary hoses. CANNOT BE USED WITH: 610-2053 GUARD, TRANSMISSION, W/MOUNT		NC
L	607-7305	HITCH, TOWING (ISO) 0 Retrieval hitch. Does not include pin. CANNOT BE USED WITH: 618-6161 GUARD, TRANSMISSION, W/MOUNT		
L	594-9944	RIPPER, STANDARD (ISO) 0 Hydraulic, rear mounted ripper with three straight ripper shanks with CapSure CR300 Hammerless ripper tips. Can accommodate two additional ripper shanks and nine scarifier teeth which must be ordered separately. CANNOT BE USED WITH: 618-6161 GUARD, TRANSMISSION, W/O MOUNT		
L	646-8314	RIPPER, MASTLESS SW RDY (ISO) 0 Hydraulic, rear mounted ripper with three straight ripper shanks with CapSure CR300 Hammerless ripper tips. Includes the mount for the Caterpillar Mastless Snow Wing on the right side of the ripper backplate. Can accommodate two additional ripper shanks, nine scarifier teeth, and the Caterpillar Mastless Snow wing which must be ordered separately. CANNOT BE USED WITH: 580-0241 STEP, ADDITIONAL ON REAR FRAME 618-6161 GUARD, TRANSMISSION, W/O MOUNT		

DOCUMENTATION

DECAL PACKAGES

L	594-3135	DECALS, PICTOGRAPH (ISO), JOY 0 Provides decals as required by ISO		NC
---	----------	---	--	----

FILM - PRODUCTION FACILITY

L	548-5882	FILM GP - BRAZIL TAX 0 Mandatory for machines built in Brazil		NC
---	----------	--	--	----

150

140/150/160

Motor Graders

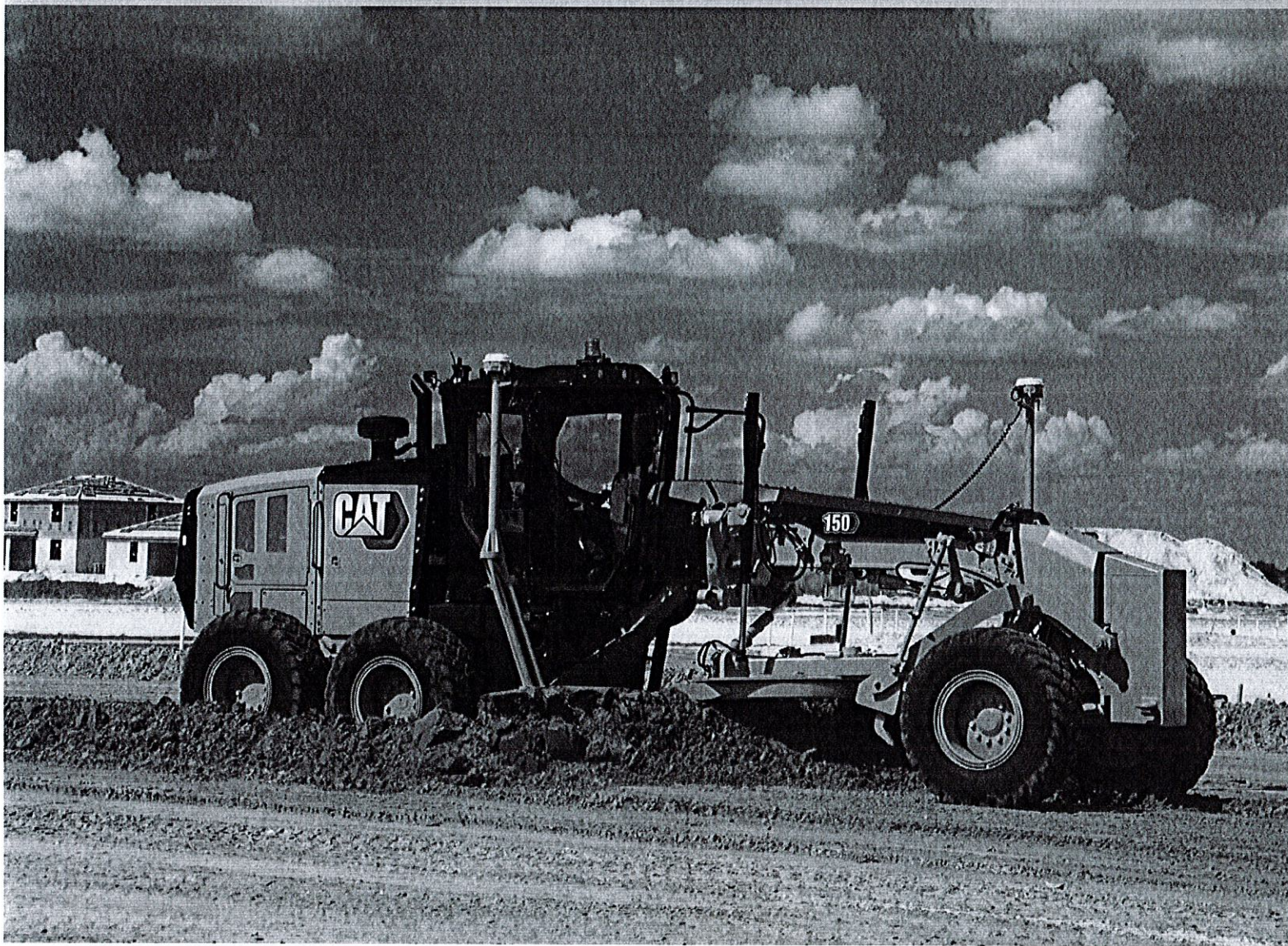

	140/140 AWD		150/150 AWD		160/160 AWD	
Engine Model	Cat® C9.3		Cat C9.3		Cat C9.3	
Base Power (1st gear) – Net	133 kW	179 hp	149 kW	200 hp	165 kW	221 hp
Base Power (1st gear) – Net (Metric)		181 hp		202 hp		224 hp
VHP Plus Range – Net	133-172 kW	179-231 hp	149-188 kW	200-252 hp	165-203 kW	221-272 hp
VHP Plus Range – Net (Metric)		181-234 hp		202-255 hp		224-276 hp
AWD Range – Net	141-188 kW	189-252 hp	156-203 kW	210-272 hp	172-219 kW	231-293 hp
AWD Range – Net (Metric)		192-255 hp		213-276 hp		234-298 hp
Moldboard – Blade Width	3.7 m	12 ft	3.7 m	12 ft	4.2 m	14 ft
Operating Weight, Typically Equipped	19 344 kg	42,647 lb	19 935 kg	43,950 lb	20 660 kg	45,547 lb
Operating Weight, Typically Equipped AWD	20 236 kg	44,614 lb	20 827 kg	45,917 lb	21 552 kg	47,514 lb

Features

Emissions Reduction

Cat emissions reduction technology is designed to be transparent to the operator and meets U.S. EPA Tier 4 Final/EU Stage V standards.

Operator Comfort

Industry leading cab and intuitive joystick controls give you unmatched comfort and visibility. New seat offers you heated/ventilated options.

Ease of Service

Drawbar-Circle-Moldboard features make it easy to maintain factory tightness for better grading results. New engine enclosure lights make service more convenient in low light.

Efficient Performance

New Economy Mode helps you save fuel – up to 10 percent.

Integrated Technologies

Cat Connect makes smart use of technology and services to help you monitor, manage and enhance job site operations.

Safety

Features like Operator Not Present monitoring, hydraulic lockout and redundant steering and braking systems help you meet your safety goals.

Contents

Operator Station.....	4
Machine and Implement Controls.....	5
Engine.....	6
Emissions Technology.....	7
Power Train.....	8
Structures and Drawbar-Circle-Moldboard.....	9
Hydraulics.....	10
All Wheel Drive (AWD).....	11
Integrated Technologies.....	12
Safety.....	14
Work Tools and Attachments.....	16
Smart Machine Systems.....	17
Serviceability and Customer Support.....	17
Sustainability.....	18
Specifications.....	19
Standard Equipment.....	33
Optional Equipment.....	34
Notes.....	35

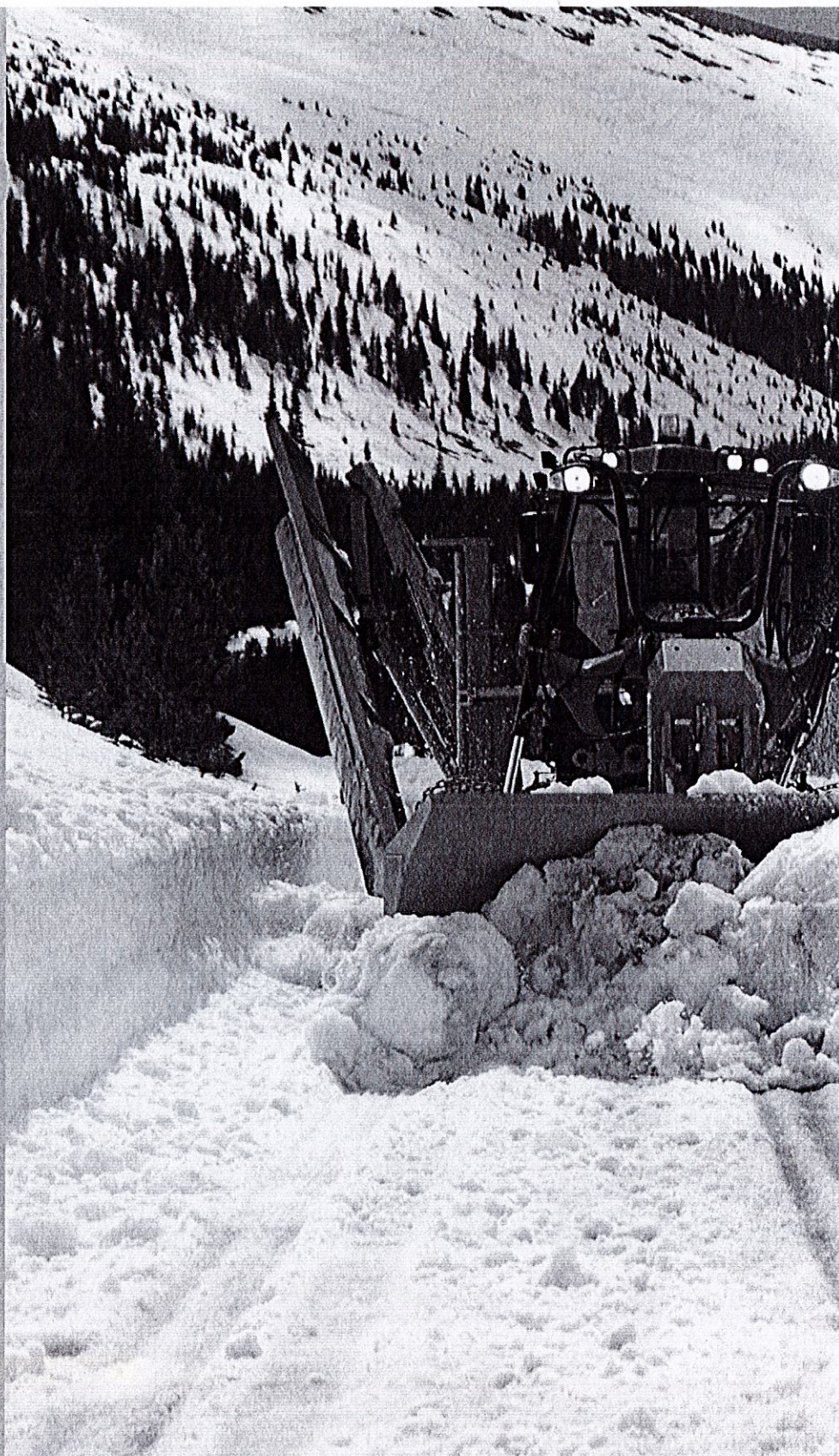



The 140/150/160 Motor Graders bring the latest emissions reduction technology to the most durable, productive and comfortable motor graders on the market. From building roads to maintaining them, motor graders are designed to help you get more work done in less time. Outstanding durability, unprecedented operator comfort and ease of service help to maximize your return on investment. The 140/150/160 Motor Graders meet U.S. EPA Tier 4 Final/EU Stage V standards.

Operator Station

Comfort, productivity, advanced technology

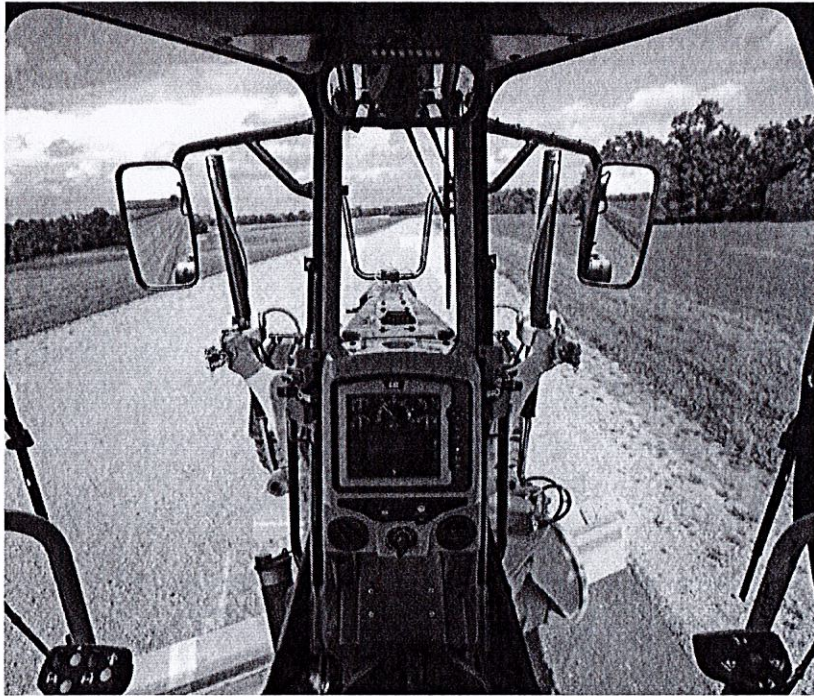

Visibility

Good visibility is key to your safety and efficiency. Angled cab doors, tapered engine enclosure and a sloped rear window make it easy to see the moldboard and tires, as well as behind the machine. An optional rear vision camera further enhances lines of sight all around the machine.

In-Dash Instrument Cluster

A redesigned message display shows machine performance and diagnostic information, including DEF tank levels. Now located in the center console, it also displays Cat Grade Control Cross Slope readings conveniently in front of the operator.

Comfort and Control

Experience the most comfortable cab in the industry. Joystick controls replace levers, so hand and arm movement is reduced by 78%, helping reduce operator fatigue for better productivity. Rocker and control switches are in easy reach.

An updated seat with softer cushions and three-position cushion tilt adds to your overall comfort. You can even upgrade to a heated or heated/ventilated seat. An optional seat belt indicator feature is also available. Control pods can be adjusted electronically, making it easy to set your ideal operating position. Multiple isolation mounts significantly reduce sound and vibration for a more relaxed work environment.

The high capacity Heating, Ventilation and Air Conditioning (HVAC) system dehumidifies and pressurizes the cab, seals out dust and helps keep windows clear. Pop-out louvers circulate fresh air. An optional deluxe radio with CD features MP3 and Bluetooth technology.

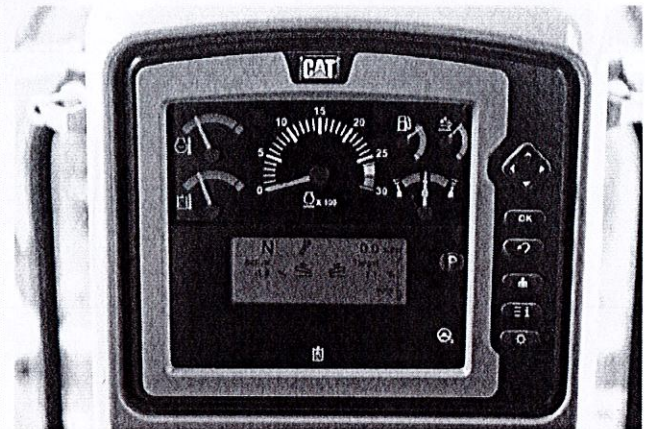

Machine and Implement Controls

Unprecedented precision and ease of operation



Two electro-hydraulic joysticks with electronically adjustable control pods help position operators for optimal comfort, visibility and productive operation.

Joystick Functions

The left joystick controls machine direction, steering, articulation, return-to-center, wheel lean, gear selection, left moldboard lift cylinder and float.

The right joystick controls drawbar, circle and moldboard functions as well as electronic throttle control and manual differential lock/unlock.

The steer tire angle matches the joystick position. A brake tensioning system holds the joystick in position until the operator moves it. The steering control automatically reduces steering sensitivity at higher ground speeds for predictable control.

Infinitely variable roller switches control the rear ripper and/or front lift group (when equipped). Optional Programmable Auxiliary Hydraulic Pod controls up to six additional hydraulic circuits.

Electronic Throttle Control

Electronic Throttle Control helps improve productivity by providing the best match of horsepower and torque for the demands of the application.

Articulation Return-to-Center

Automatically returns the machine to a straight frame position from any angle with the touch of a button.

Selectable Blade Lift Modes

Choose the blade lift modulation mode that best fits your application or operating style: Fine, Normal, or Coarse.

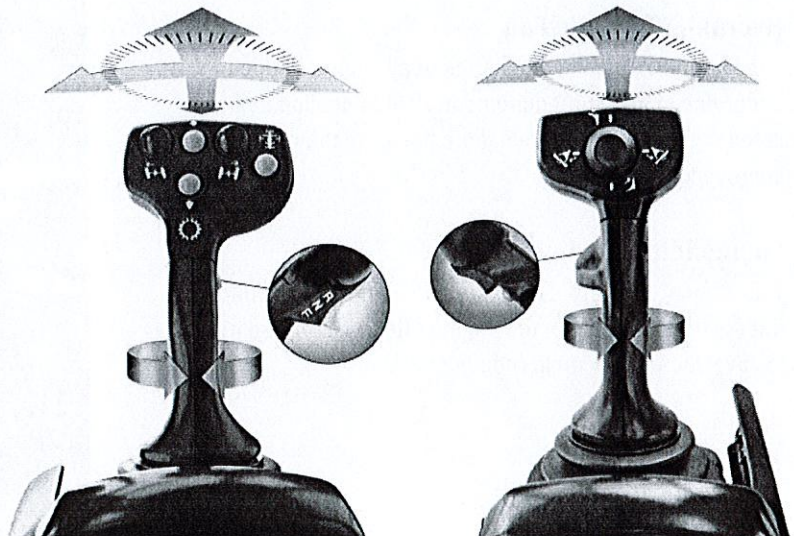

Engine

Power and reliability

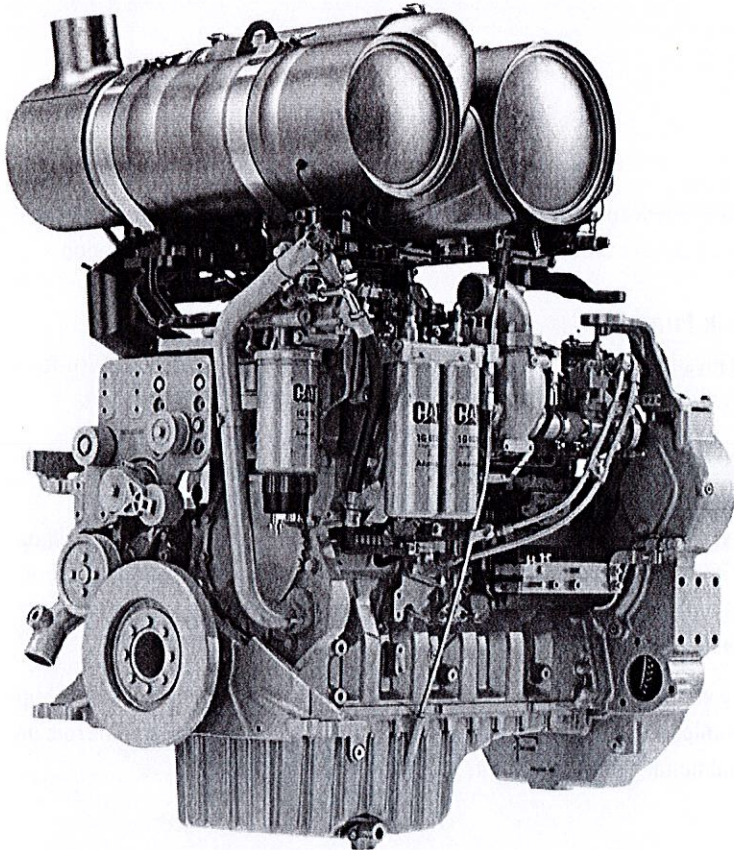

A Cat C9.3 engine gives you the performance you need to maintain consistent grading speeds for maximum productivity. Every U.S. EPA Tier 4 Final/EU Stage V engine is equipped with a combination of proven electronic, fuel, air and aftertreatment components. Applying proven technologies systematically and strategically helps meet your high expectations for productivity, fuel efficiency, reliability and service life.

Hydraulic Demand Fan

The hydraulic demand fan automatically adjusts speed according to cooling requirements. When cooling demand is reduced, you benefit from more power to the ground and improved fuel efficiency.

Engine Idle Shutdown Timer

This standard feature can be software-enabled by your Cat dealer to shut down the engine after a set period of time to save you fuel and help reduce emissions.

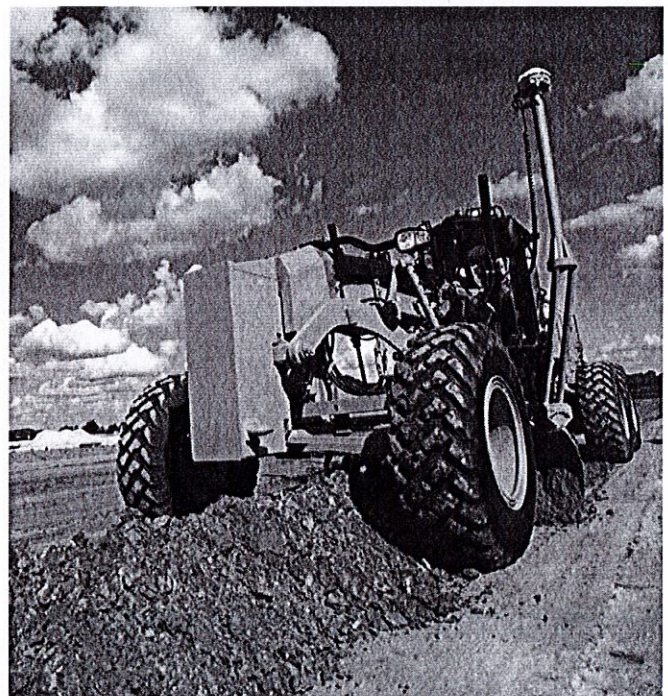

Emissions Technology

Proven, integrated solutions

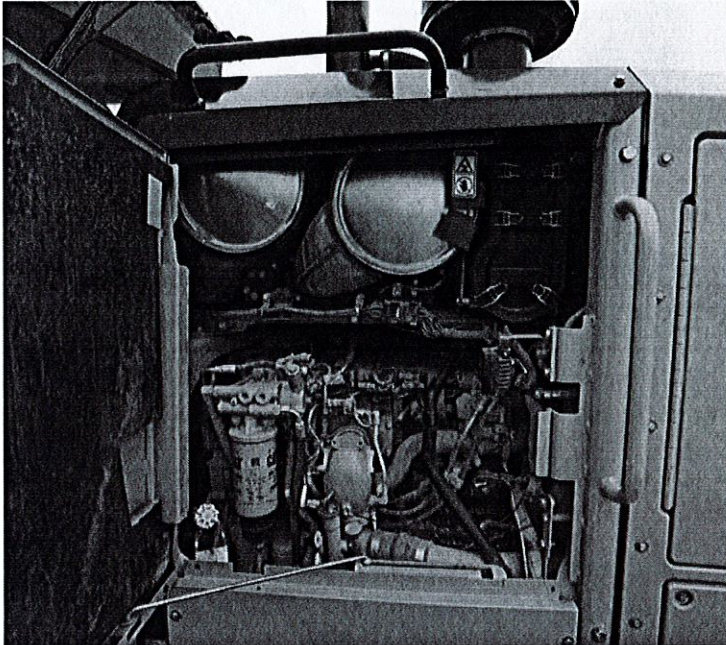

Emissions reduction technology on the 140/150/160 Motor Graders is designed to be transparent, with no action required from the operator. There is no need to stop. Regeneration runs automatically at cold start-up and, if needed, in the background while you work.

Aftertreatment Technologies

Caterpillar designed Tier 4 Interim products with Tier 4 Final standards in mind. To meet the additional 80 percent reduction in NOx emissions required by EPA Tier 4 Final/EU Stage V emission standards, Caterpillar engineers only needed to add one new system to the already proven aftertreatment solution in use, Selective Catalytic Reduction (SCR).



Diesel Exhaust Fluid

Selective Catalytic Reduction utilizes Diesel Exhaust Fluid (DEF), which can be conveniently filled from ground level. Simply refill the DEF tank when you refuel. A gauge on the dash shows your fluid level.

When you turn the machine off, a pump will automatically purge the DEF lines. A light located inside the rear engine compartment will turn off, telling you the purge is complete and that it is safe to turn off the electrical disconnect. If the engine/aftertreatment temperatures are high, a Delayed Engine Shutdown will activate automatically to cool the machine and then purge the lines.



For complete aftertreatment information, please refer to your machine's Operation and Maintenance Manual.

Power Train

Maximum power to the ground

- Standard Automatic Differential Lock/Unlock monitors machine and application parameters to unlock/re-lock the differential during operation, improving production and enhancing comfort while protecting the power train.
- Full Electronic Clutch Pressure Control optimizes inching modulation for smooth shifts and directional changes.
- Programmable Autoshift option simplifies operation by allowing you to program the transmission to shift at optimal points to match your application.
- New standard Economy Mode can be turned on to help save fuel by reducing engine speed so the machine works in a more efficient range. The average fuel savings is up to 10 percent, depending on the application.
- Power Shift Countershaft Transmission maximizes power to the ground.
- Engine Over-Speed Protection prevents downshifting until an acceptable safe travel speed has been established.

Front and Rear Axles

The sealed spindle keeps front axle bearings lubricated and protected from contaminants. The Cat "Live Spindle" design places the larger tapered roller bearing on the outside, where the load is greater, extending bearing life. A bolt-on modular rear axle improves serviceability and contamination control with easy access to differential components.

Hydraulic Brakes

Oil-bathed multi-disc service brakes are hydraulically actuated for smooth, predictable braking and lower operating costs. Brakes are located at each tandem wheel and have a large total brake surface area to give you dependable stopping power and longer life.

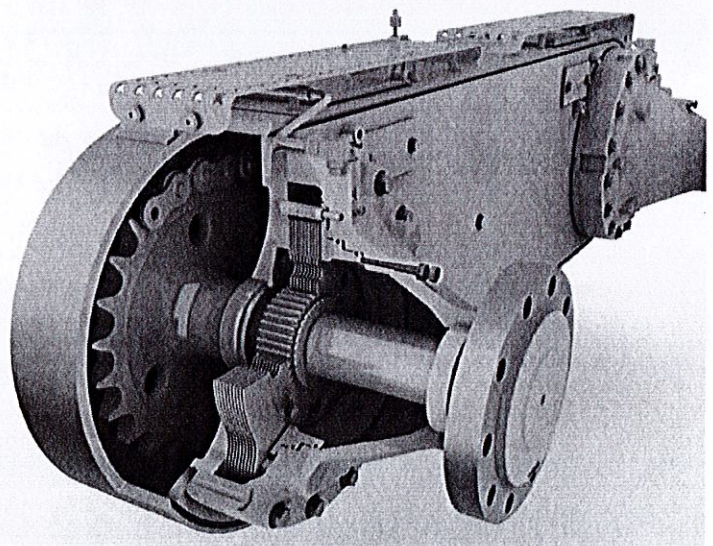
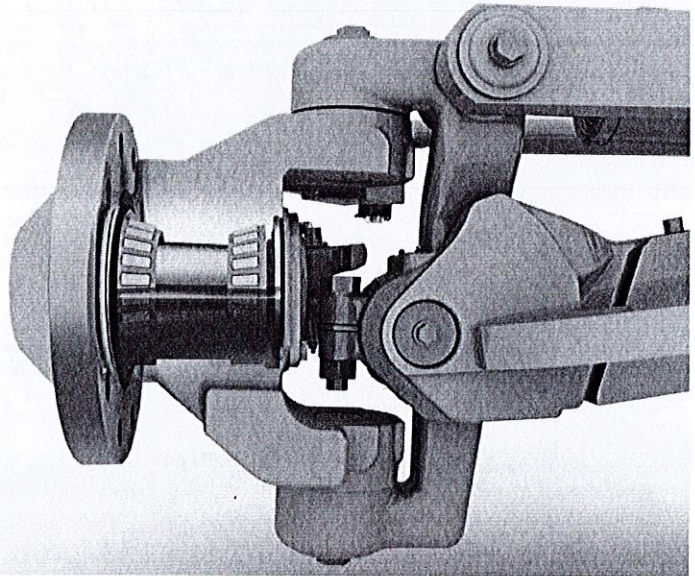
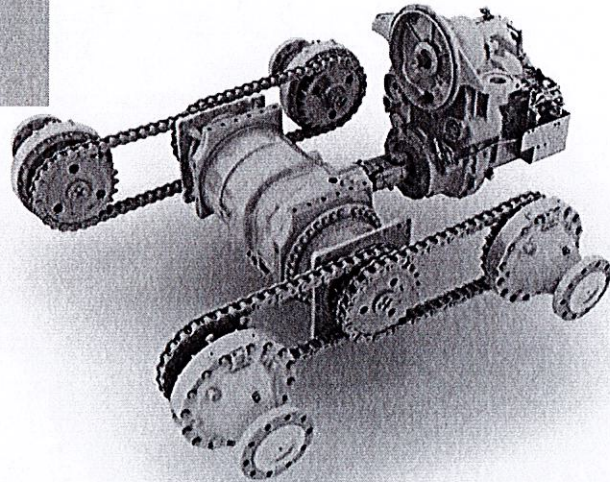

Structures and Drawbar-Circle-Moldboard

Service ease and precise blade control

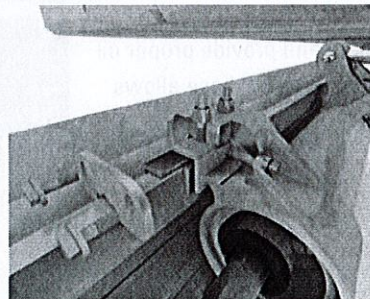
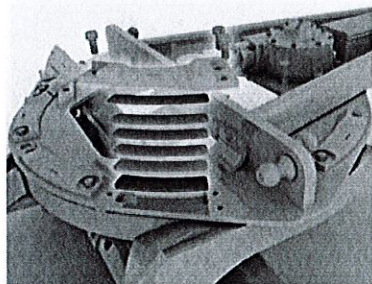
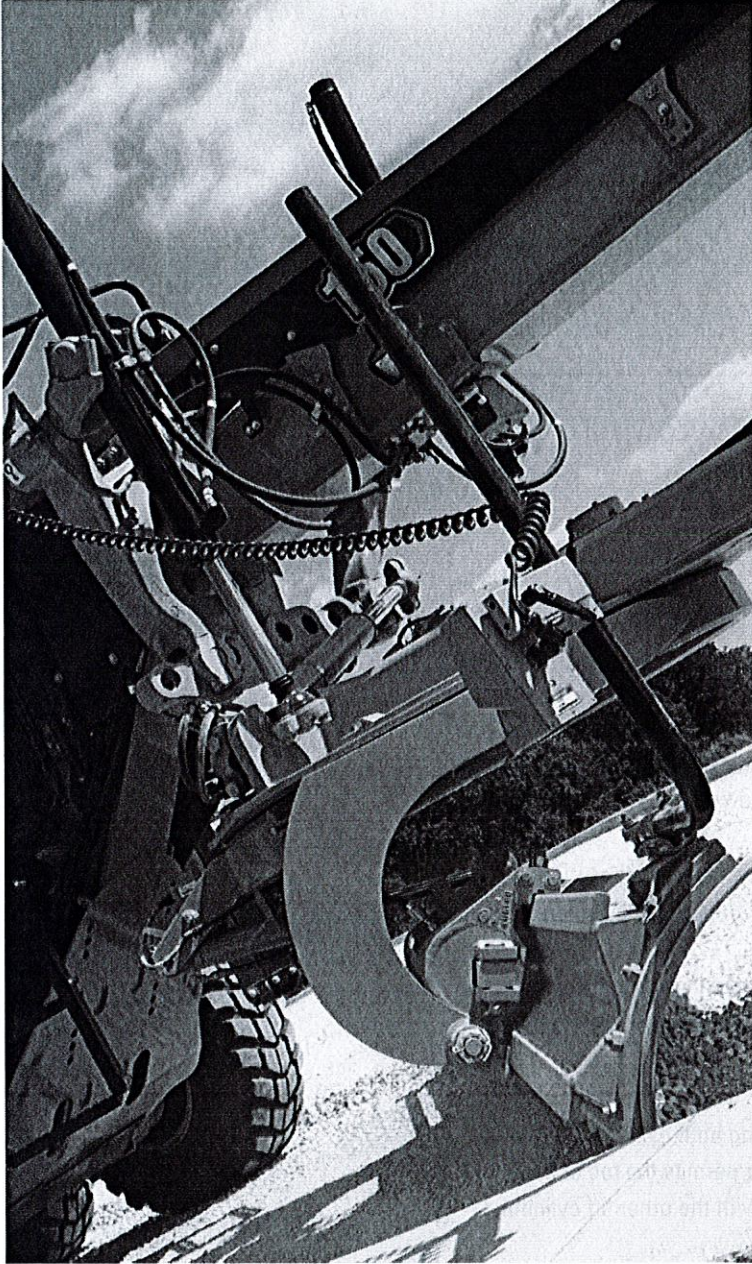

Caterpillar designs motor grader frame and drawbar components to give you performance and durability. The one-piece forged steel circle stands up to high stress loads, and a sacrificial wear system helps keep your service time and costs down.

The articulation hitch features a large tapered roller bearing to carry loads evenly and smoothly. It is sealed to prevent contamination and a locking pin prevents articulation for safety during service or transport.

Easy Maintenance for More Uptime

The drawbar, circle and moldboard are designed to make it easy to keep the components tight. One person can easily adjust or replace the patented top-adjust drawbar wear inserts from the top of the drawbar plate, reducing downtime to save you money. Durable nylon composite wear inserts maximize circle torque and component life. Sacrificial brass wears strips between the blade mounting group and moldboard can be easily adjusted and replaced. The Shimless Moldboard Retention System uses vertical and horizontal adjusting screws to keep moldboard wear strips aligned for reduced blade chatter and precise blade control.

Blade Angle and Moldboard

An aggressive blade angle, optimized moldboard curvature and large throat clearance help you work more efficiently by allowing material to roll more freely along the blade.

Heat-treated rails, hardened cutting edges and end bits, and heavy duty bolts to give you greater moldboard reliability and long service life. The link bar allows extreme moldboard positioning for easier bank sloping and ditch cutting/cleaning.

Hydraulics

Advanced machine control



Responsive Hydraulics

A proven load-sensing system and advanced electro-hydraulics give you superior implement control and responsive hydraulic performance that helps make your operator's job easier. Continuously matching hydraulic flow/pressure to power demands creates less heat and reduces power consumption.

- Consistent, Predictable Movement – Proportional Priority Pressure-Compensating (PPP-C) valves have different flow rates for the head and rod ends of the cylinder, so you can count on consistent, predictable implement response.
- Balanced Flow – Hydraulic flow is proportioned to give you confidence that all implements will operate simultaneously without slowing the engine or speed of some implements.

Blade Float

Allows the blade to move freely under its own weight. By floating both cylinders, the blade can follow the contours of the ground. Floating only one cylinder permits the toe of the blade to follow a hard surface while the operator controls the slope with the other lift cylinder.

Independent Oil Supply

Large, separate hydraulic oil supplies prevent cross-contamination and provide proper oil cooling, which reduces heat build-up and extends component life. Cat XT™ hose allows high pressures for maximum power and reduced downtime.

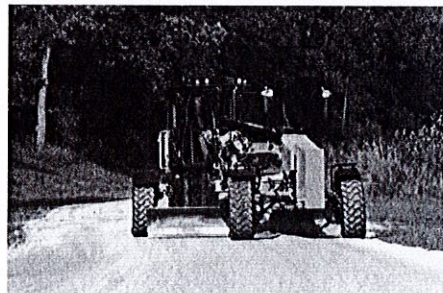
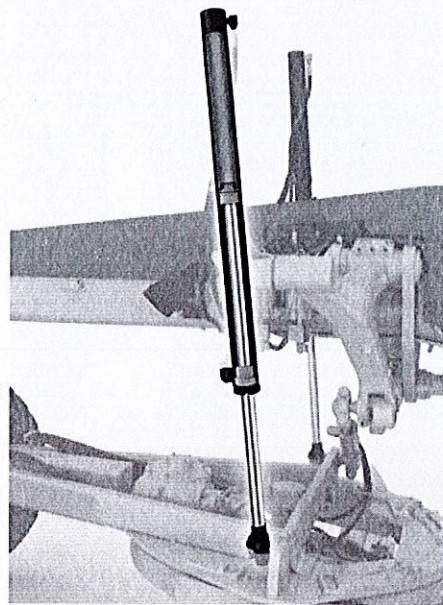

All Wheel Drive (AWD)

Expanded machine versatility

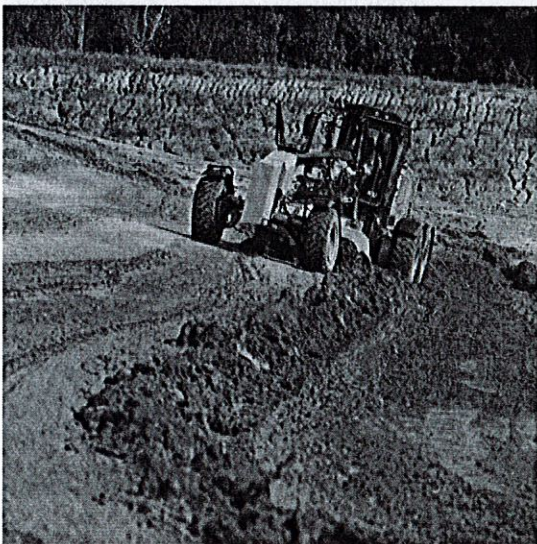

■ Without Steering Compensation ■ With Steering Compensation

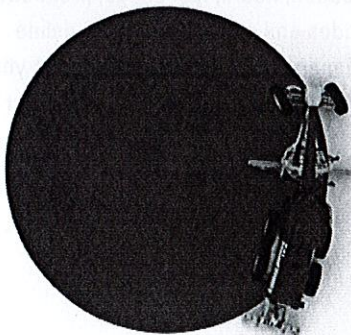

If you work in soft underfoot conditions where traction can be a challenge, optional All Wheel Drive (AWD) can give you the additional power to the ground you need to work more efficiently in mud, gravel, sand or snow. The added traction helps reduce sliding on side slopes.

- Dedicated left and right pumps give you more precise hydraulic control. The infinitely variable pumps and motors maximize torque in each gear.
- AWD automatically increases horsepower to maximize your power to the ground.
- Standard Hydrostatic Mode disengages the transmission and provides hydraulic power to the front wheels only. Infinitely variable ground speed between 0-8 km/h (0-5 mph) is ideal for precise finish work.
- Cat Steering Compensation System enables a "powered turn" by adjusting the outside front tire speed up to 50% faster than the inside tire. This gives you improved control, reduces surface damage and greatly reduces turning radius in poor underfoot conditions.

Integrated Technologies

Monitor, manage, and enhance job site operations



Cat Connect makes smart use of technology and services to improve your job site efficiency. Using the data from technology-equipped machines, you'll get more information and insight into your equipment and operations than ever before.

Cat Connect technologies offer improvements in these key areas:



Equipment Management – increase uptime and reduce operating costs.



Productivity – monitor production and manage job site efficiency



Safety – enhance job site awareness to keep your people and equipment safe.

Featured Cat Connect technologies include:

Link

Link technologies provide wireless capability to machines enabling two-way transfer of information collected by on-board sensors, control modules, and other Cat Connect technologies using off-board apps, such as our VisionLink software.

Product Link™/VisionLink®

Product Link takes the guesswork out of equipment management. Track location, hours, fuel usage, productivity, idle time, diagnostic codes and more through the online VisionLink interface. Manage your fleet in real time so you can maximize efficiency, improve productivity, and lower operating costs.



Grade

Grade technologies combine digital design data, in-cab guidance, and automatic blade controls to enhance grading accuracy, reduce rework, and lower costs related to production earthmoving and rough, fine and finish grade applications.

Cat Grade Control Cross Slope

Cat Grade Control Cross Slope is an optional fully integrated, factory installed system that helps your operator improve grading efficiency and more easily maintain accurate cross slopes. The system automatically controls one side of the blade, reducing manual operator inputs by as much as 50 percent. Experienced operators can maintain peak efficiency levels throughout more of the work day, while less experienced operators can be more productive faster. The system is job-ready from day one, and scalable for the future with AccuGrade™ upgrade kits that provide additional 2D and/or 3D control.



Cat AccuGrade

AccuGrade is an optional dealer-installed grade control system that provides higher accuracy capabilities to the Cat Cross Slope system by adding Sonic, Laser, GPS, and/or Universal Total Station (UTS) technology when the job requires. In-cab guidance helps operators work more confidently and get to grade faster, in fewer passes, using less material, improving productivity and accuracy by nearly 50 percent over conventional methods. Grade stakes and checkers are minimized, making the job site safer and more cost effective. An AccuGrade Attachment Ready Option can be ordered as a factory or dealer-installed option. It includes built-in mounting points and internal wiring for easy installation of the AccuGrade system.

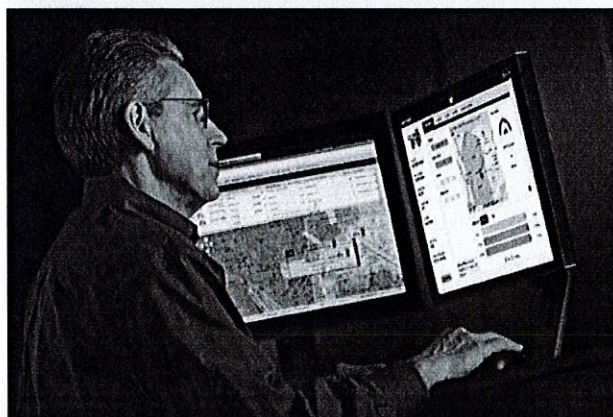

Safety

Designed with protection in mind

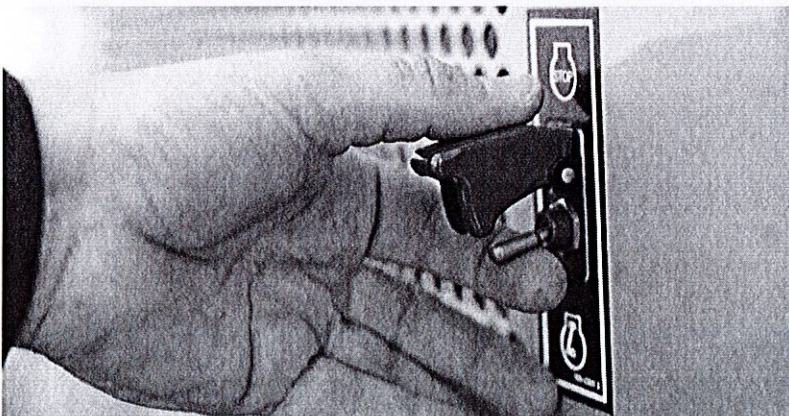
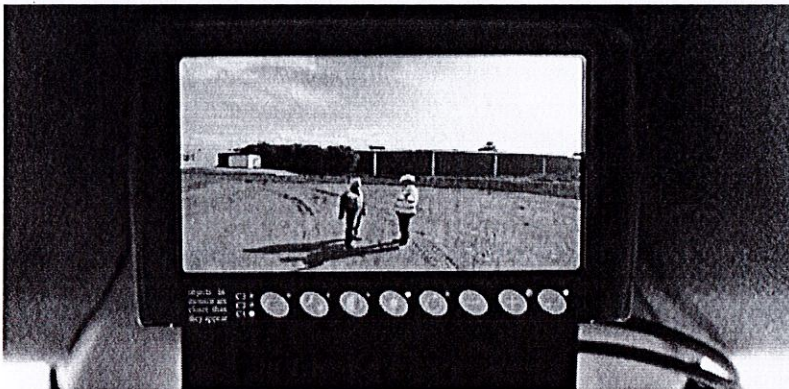

Safety Features

- Optional rearview camera with in-cab monitor
- New optional seat belt indicator light reminds operator to fasten safety belt
- Grouped, ground level service points
- Laminated front window glass
- Optional LED Lighting
- Ground-level electrical disconnect switch
- Ground-level engine shutoff switch
- Anti-glare paint eases night operation
- Optional front and rear fenders

Operator Presence Monitoring System

Standard system keeps the parking brake engaged and hydraulic implements disabled until the operator is seated and the machine is ready for operation.

Speed Sensitive Steering

Standard function makes steering less sensitive as ground speed increases for greater operator confidence and control.

Secondary Steering System

Standard feature automatically engages an electric hydraulic pump in case of a drop in steering pressure so the operator can steer the machine to a stop.

Hydraulic Lockout

Disables all implement functions while still providing machine steering control. This standard safety feature is especially useful while roading.

Brake Systems

Brakes are located at each tandem wheel to eliminate braking loads on the power train. Redundant brake systems utilize accumulators to enable stopping in case of machine failure.

Walkways and Grab Rails

Perforated steel tandem walkways and convenient grab rails give you a sturdy platform when moving on, off and around the machine.

Circle Drive Slip Clutch

Protects the drawbar, circle and moldboard from shock loads when the blade encounters an immovable object. This standard feature also reduces the possibility of abrupt directional changes in poor traction conditions.

Blade Lift Accumulators

Help absorb impact loads to the moldboard by allowing vertical blade travel. This optional feature helps reduce wear and aids operator safety.

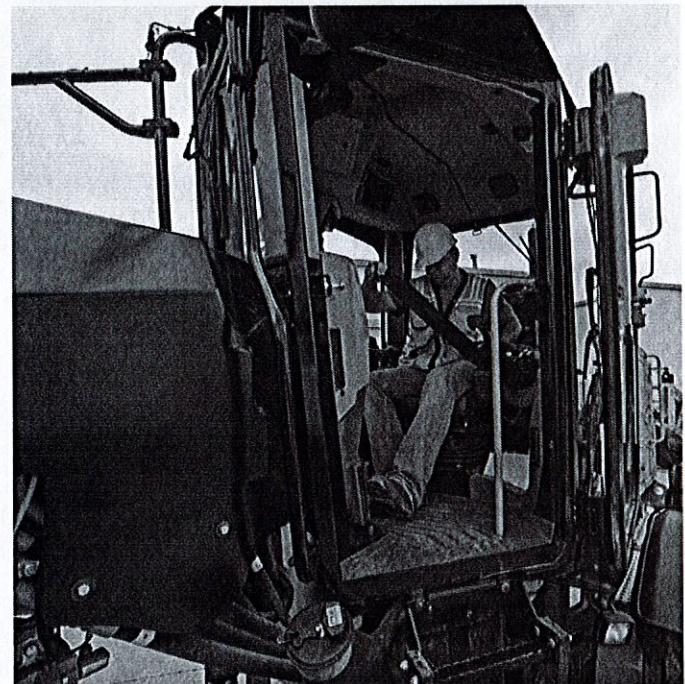

Work Tools and Attachments

Equip your machine for the job

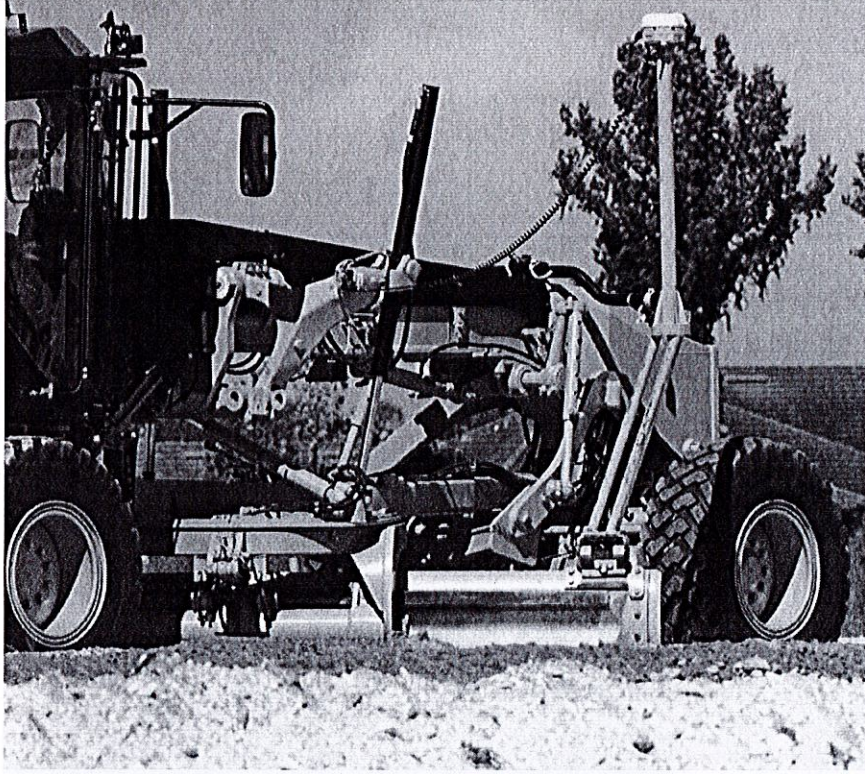

Moldboard Options

The 140, 150, and 160 motor graders come equipped with a 3.7 m (12 ft) moldboard.

An optional 4.3 m (14 ft) blade is available for all models, as well as a 4.9 m (16 ft) moldboard for the 160.

Ground Engaging Tools (GET)

A variety of tools are available from Cat Work Tools, including cutting edges, graderbits and end bits, all designed for maximum service life and productivity.

Front Mounted Groups

A front mounted push plate or front lift group are available. The front lift group can be combined with a front dozer blade or front scarifier for added versatility.

Rear Ripper/Scarifier

Made to penetrate tough material fast and rip thoroughly for easier movement with the moldboard. The ripper includes three shanks (with holders for five). Nine scarifier shanks can also be added for additional versatility.

Snow Removal Work Tools

Snow plow, snow wing and mounting options increase machine versatility and utilization throughout the year.

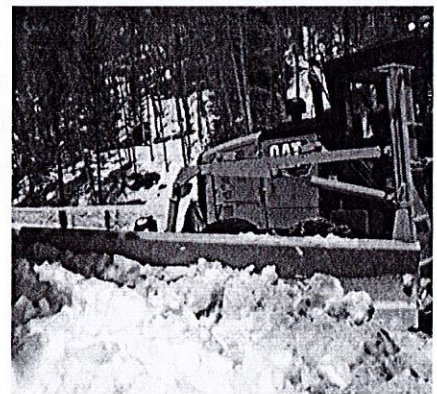

Smart Machine Systems

Advanced Diagnostics

- Cat Messenger, combined with full systems integration, enhances diagnostic capability for quick analysis of critical data.
- Electronic Technician (Cat ET) lets service technicians access stored diagnostic data and configure machine parameters through the Cat Data Link.
- Low Battery Elevated Idle raises idle speed when low system voltage is detected, ensuring adequate system voltage and improving battery reliability.
- Automatic Engine Deration protects the engine by automatically lowering engine torque output and alerting the operator if critical conditions are detected.

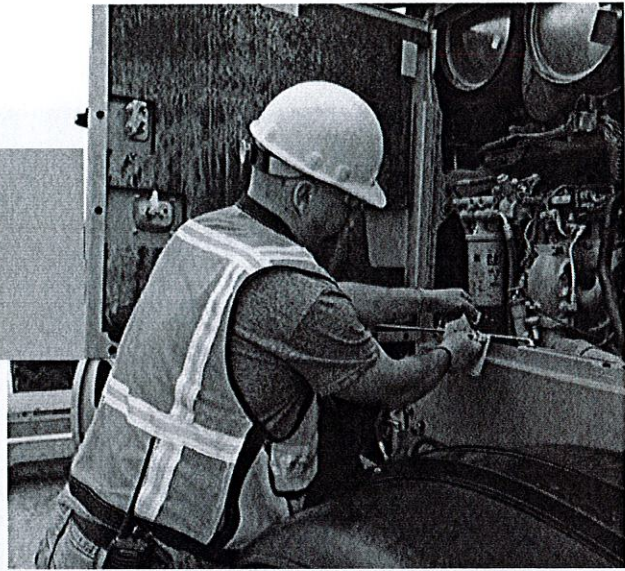

Serviceability and Customer Support

When uptime counts

Cat motor graders are designed to help you increase uptime and reduce costs. Grouped service points and extended service intervals save maintenance time. New optional LED lights in the left hand compartment makes it more convenient to service the machine in low light.

Unparalleled Dealer Support

When it comes to supporting you, Cat dealers are second to none. From machine selection and purchase to maintenance support and rebuilds, Cat dealers have the experience and capabilities to help keep you up and running.



Sustainability

Thinking generations ahead



Fuel Efficiency

- Integrated machine systems and technologies improve productivity for greater accuracy, allowing the machine to do more work per gallon of fuel.
- New Economy Mode feature allows the machine to work in the most efficient engine speed range to help reduce fuel use.

Green House Gas Emissions

- Reduced fuel consumption means reduced CO₂ emissions.

Material Efficiency and Lifecycle Costs

- Replaceable wear parts save maintenance time and cost, and extend major component life.
- Major components are built to be rebuilt, eliminating waste and saving customers money by giving the machine and/or major components a second – and even third – life.
- Approximately 95% of machine materials can be recycled (ISO 16714) to conserve valuable natural resources and further enhance machine end-of-life value.

Sound

- Reduced engine noise and quieter cabs mean lower operator and spectator sound levels.

Safety

- Ecology drains help make draining fluids more convenient and help prevent spills.
- Cartridge style hydraulic fluid filters provide safe clean draining of filters prior to replacement, helping to prevent fluid spills.
- A variety of safety features help safeguard operators and others on the job site.

150/150 AWD Motor Graders Specifications

Engine

Engine Model	Cat C9.3		
Emissions	U.S. EPA Tier 4 Final/ EU Stage V		
Base Power (1st gear) – Net	149 kW	200 hp	
Base Power (1st gear) – Net (Metric)	202 hp		
VHP Plus Range – Net	149-188 kW	200-252 hp	
VHP Plus Range – Net (Metric)	202-255 hp		
AWD Range – Net	156-203 kW	210-272 hp	
AWD Range – Net (Metric)	213-276 hp		
Displacement	9.3 L	567.5 in ³	
Bore	115 mm	4.5 in	
Stroke	149 mm	5.9 in	
Torque Rise	39%		
Maximum Torque (VHP Plus)	1247 N·m	920 lb-ft	
Maximum Torque (AWD On)	1355 N·m	1,000 lb-ft	
Speed @ Rated Power	2,000 rpm		
Number of Cylinders	6		
Derating Altitude	3050 m	10,000 ft	
High Ambient – Fan Speed			
Standard	1,400 rpm		
Maximum	1,550 rpm		
Minimum	500 rpm		
Standard Capability	43° C	109° F	
High Ambient Capability	50° C	122° F	
Gear – Net Power	VHP Plus kW (hp)	AWD Off kW (hp)	AWD On kW (hp)
Forward			
1st	149 (200)	156 (210)	164 (220)
2nd	156 (210)	164 (220)	180 (241)
3rd	164 (220)	172 (231)	184 (247)
4th	172 (231)	176 (236)	188 (252)
5th	176 (236)	180 (241)	203 (272)
6th	180 (241)	184 (247)	203 (272)
7th	184 (247)	188 (252)	203 (272)
8th	188 (252)	188 (252)	203 (272)
Reverse			
1st	149 (200)	149 (200)	149 (200)
2nd	156 (210)	156 (210)	156 (210)
3rd–6th	164 (220)	164 (220)	164 (220)

Engine (cont'd)

- Net power is tested per ISO 9249, SAE J1349, and EEC 80/1269 Standards in effect at the time of manufacture.
- VHP Plus is standard for the 150/150 AWD.
- Net power advertised is the power available at rated speed of 2,000 rpm, measured at the flywheel when engine is equipped with fan running at minimum speed, air cleaner, muffler and alternator.
- No engine derating required up to 3050 m (10,000 ft).
- Power as declared per ISO 14396
Rated rpm 2,000
VHP+ = 189 kW (253 hp)
AWD = 204 kW (274 hp)
- All nonroad U.S. EPA Tier 4, European Union (EU) Stage V and Japan (MLIT) Step 4 diesel engines are required to use only Ultra Low Sulfur Diesel (ULSD) fuels containing 15 ppm (mg/kg) sulfur or less. Biodiesel blends up to B20 (20% blend by volume) are acceptable when blended with 15 ppm (mg/kg) sulfur or less ULSD. B20 should meet ASTM D7467 specification (biodiesel blend stock should meet Cat biodiesel spec, ASTM D6751 or EN 14214). Cat DEO-ULS or oils that meet the Cat ECF-3, API CJ-4, and ACEA E9 specification are required. Consult your OMM for further machine specific fuel recommendations.
- Cat engines equipped with a Selective Catalytic Reduction (SCR) system are required to use:
 - Diesel Exhaust Fluid (DEF) which meets the requirements outlined in the International Organization for Standardization (ISO) standard 22241-1.

Power Train

Forward/Reverse Gears	8 Forward/6 Reverse
Transmission	APECS, Direct Drive, Powershift
Brakes	
Service	Multiple Oil Disc
Service, Surface Area	23 000 cm ² 3,565 in ²
Parking	Multiple Oil Disc
Secondary	Dual Circuit

Hydraulic System

Circuit Type	Parallel
Pump Type	Variable Piston
Pump Output	210 L/min 55.7 gal/min
Maximum System Pressure	24 150 kPa 3,500 psi
Reservoir Tank Capacity	64.0 L 16.9 gal
Standby Pressure	6100 kPa 885 psi

- Pump output measured at 2,150 rpm.

150/150 AWD Motor Graders Specifications

Operating Specifications

Top Speed		
Forward	46.6 km/h	29.0 mph
Reverse	36.8 km/h	23.0 mph
Turning Radius, Outside Front Tires		
	7.8 m	25 ft 7 in
Steering Range – Left/Right		
	50°	
Articulation Angle – Left/Right		
	20°	
Forward		
1st	4.1 km/h	2.5 mph
2nd	5.5 km/h	3.4 mph
3rd	8.0 km/h	5.0 mph
4th	11.0 km/h	6.9 mph
5th	17.1 km/h	10.6 mph
6th	23.3 km/h	14.5 mph
7th	32.0 km/h	19.9 mph
8th	46.6 km/h	29.0 mph
Reverse		
1st	3.2 km/h	2.0 mph
2nd	6.0 km/h	3.7 mph
3rd	8.7 km/h	5.4 mph
4th	13.5 km/h	8.4 mph
5th	25.3 km/h	15.7 mph
6th	36.8 km/h	23.0 mph

• Calculated with no slip and 14.0R24 tires.

Service Refill

Fuel Capacity	394 L	104 gal
Cooling System	57.0 L	15.0 gal
Hydraulic System		
Total	100 L	26.4 gal
Tank	64.0 L	16.9 gal
Engine Oil	30.0 L	7.9 gal
Trans./Diff./Final Drives	70.0 L	18.5 gal
Tandem Housing (Each)	76.0 L	20.0 gal
Front Wheel Spindle Bearing Housing	0.5 L	0.13 gal
Circle Drive Housing	7.0 L	1.8 gal
Diesel Exhaust Fluid	22.0 L	5.8 gal

Frame

Circle		
Diameter	1530 mm	60.2 in
Height	138 mm	5.4 in
Blade Beam Thickness	40.0 mm	1.6 in
Drawbar		
Height	152 mm	6.0 in
Width	76.2 mm	3.0 in
Thickness	12.7 mm	0.50 in
Front-Top/Bottom Plate		
Width	305 mm	12.0 in
Thickness	22.0 mm	0.87 in
Front Frame Structure		
Height	321 mm	12.6 in
Width	305 mm	12.0 in
Front Axle		
Height to Center	596 mm	23.5 in
Wheel Lean, Left/Right	18°	
Total Oscillation per Side	32°	

• Front-top/bottom plate – width tolerance ± 2.5 mm (0.098 in).

Tandems

Height	506 mm	19.9 in
Width	201 mm	7.9 in
Sidewall Thickness		
Inner	16.0 mm	0.63 in
Outer	18.0 mm	0.71 in
Drive Chain Pitch	50.8 mm	2.0 in
Wheel Axle Spacing	1523 mm	60.0 in
Tandem Oscillation		
Front Up	15°	
Front Down	25°	

150/150 AWD Motor Graders Specifications

Moldboard

Blade Width	3.7 m	12 ft
Moldboard		
Height	610 mm	24.0 in
Thickness	22.0 mm	0.87 in
Arc Radius	413 mm	16.3 in
Throat Clearance	166 mm	6.5 in
Cutting Edge		
Width	152 mm	6.0 in
Thickness	16.0 mm	0.60 in
End Bit		
Width	152 mm	6.0 in
Thickness	16.0 mm	0.60 in
Blade Pull		
Base GVW	11 672 kg	25,732 lb
Maximum GVW	15 541 kg	34,262 lb
Base GVW (AWD)	16 484 kg	36,341 lb
Maximum GVW (AWD)	22 512 kg	49,630 lb
Blade Down Pressure		
Base GVW	7475 kg	16,480 lb
Maximum GVW	13 294 kg	29,308 lb
Base GVW (AWD)	8351 kg	18,411 lb
Maximum GVW (AWD)	13 294 kg	29,308 lb

Blade Range

Circle Centershift		
Right	728 mm	28.7 in
Left	695 mm	27.4 in
Moldboard Sideshift		
Right	660 mm	26.0 in
Left	510 mm	20.1 in
Maximum Blade Position Angle	90°	
Blade Tip Range		
Forward	40°	
Backward	5°	
Maximum Shoulder Reach Outside of Tires		
Right	1978 mm	77.9 in
Left	1790 mm	70.5 in
Maximum Lift Above Ground	480 mm	18.9 in
Maximum Depth of Cut	715 mm	28.1 in

Ripper

Ripping Depth, Maximum	426 mm	16.8 in
Ripper Shank Holders	5	
Ripper Shank Holder Spacing	533 mm	21.0 in
Penetration Force	9440 kg	20,812 lb
Pryout Force	12 607 kg	27,794 lb
Machine Length Increase, Beam Raised	1031 mm	40.6 in

Scarifier

Front, V-Type: Working Width	1205 mm	47.4 in
Front, V-Type, 5 or 11 Tooth		
Working Width	1031 mm	40.6 in
Scarifying Depth, Maximum	467 mm	18.4 in
Scarifier Shank Holders	5/11	
Scarifier Shank Holder Spacing	116 mm	4.6 in
Mid, V-Type		
Working Width	1184 mm	46.6 in
Scarifying Depth, Maximum	292 mm	11.5 in
Scarifier Shank Holders	11	
Scarifier Shank Holder Spacing	116 mm	4.6 in
Rear		
Working Width	2133 mm	84.0 in
Scarifying Depth, Maximum	426 mm	16.8 in
Scarifier Shank Holders	9	
Scarifier Shank Holder Spacing	267 mm	10.5 in

Weights

Gross Vehicle Weight, Base		
Total	17 323 kg	38,191 lb
Front Axle	4355 kg	9,601 lb
Rear Axle	12 968 kg	28,590 lb
Gross Vehicle Weight, Maximum		
Total	25 013 kg	55,144 lb
Front Axle	7745 kg	17,075 lb
Rear Axle	17 268 kg	38,069 lb
Operating Weight, Typically Equipped		
Total	19 935 kg	43,950 lb
Front Axle	5692 kg	12,549 lb
Rear Axle	14 243 kg	31,401 lb

150/150 AWD Motor Graders Specifications

Weights – AWD

Gross Vehicle Weight, Base		
Total	18 316 kg	40,380 lb
Front Axle	4865 kg	10,726 lb
Rear Axle	13 451 kg	29,654 lb
Gross Vehicle Weight, Maximum		
Total	25 013 kg	55,144 lb
Front Axle	7745 kg	17,075 lb
Rear Axle	17 268 kg	38,069 lb
Operating Weight, Typically Equipped		
Total	20 827 kg	45,917 lb
Front Axle	6169 kg	13,601 lb
Rear Axle	14 658 kg	32,316 lb

- Base operating weight on standard machine configuration is calculated with full fuel tank, coolant, lubricants, operator and 14.0R24 tires with multi-piece (MP) rims.
- Typically equipped operating weight is calculated with push block, transmission guard, rear ripper/scarifier, 14.0R24 tires with multi-piece (MP) rims, and other equipment.

Standards

ROPS/FOPS	ISO 3471/ISO 3499
Steering	ISO 5010
Brakes	ISO 3450
Sound	ISO 6394; ISO 6395

- The declared dynamic operator sound pressure level is 71 dB(A) for the 150 and 150 AWD when "ISO 6396:2008" is used to measure the value for a European Union "CE" marked machine. The measurement was conducted at 70% of the maximum engine cooling fan speed. The sound level may vary at different engine cooling fan speeds.
- The declared exterior sound power level is 107 dB(A) for the 150 and 150 AWD when the value is measured according to the dynamic test procedures and the conditions that are specified in "ISO 6395:2008." The measurement was conducted for a European Union "CE" marked machine at 70% of the maximum engine cooling fan speed. The sound level may vary at different engine cooling fan speeds and during diesel particulate filter regeneration.

Air Conditioning System

The air conditioning system on this machine contains the fluorinated greenhouse gas refrigerant R134a (Global Warming Potential = 1430). The system contains 1.8 kg of refrigerant which has a CO₂ equivalent of 2.574 metric tonnes.

Motor Graders Specifications

Dimensions

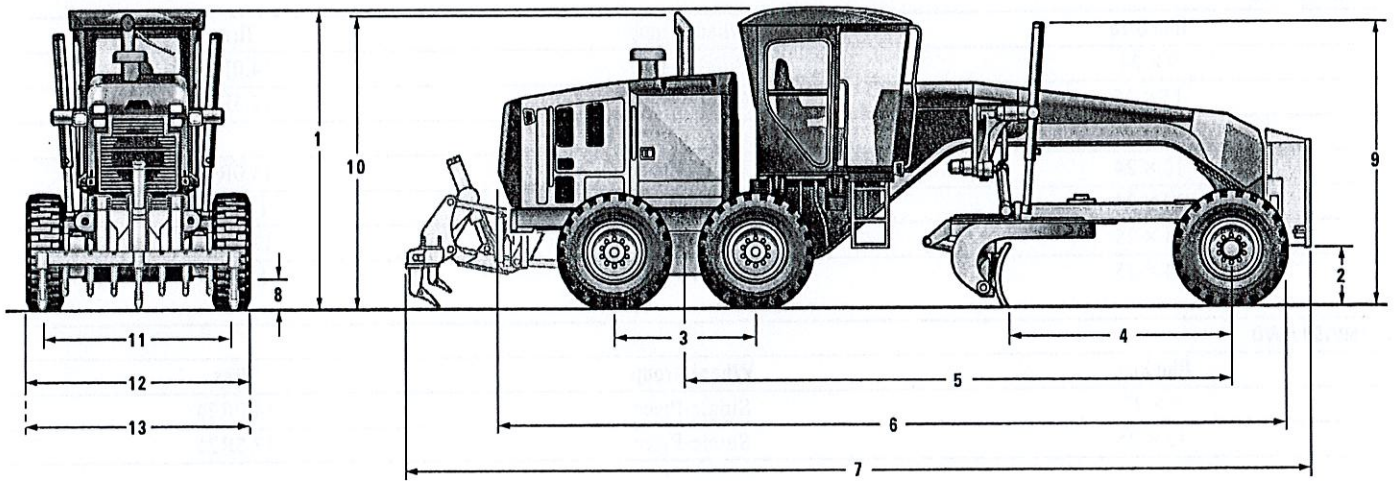

	140/140 AWD		150/150 AWD		160/160 AWD	
	mm	in	mm	in	mm	in
1 Height - Top of Cab	3308	130	3308	130	3308	130
2 Height - Front Axle Center	596	23.5	596	23.5	596	23.5
3 Length - Between Tandem Axles	1523	60.0	1523	60.0	1523	60.0
4 Length - Front Axle to Moldboard	2552	100	2552	100	2552	100
5 Length - Front Axle to Mid Tandem	6123	241	6123	241	6123	241
6 Length - Front Tire to Rear of Machine	8912	351	8912	351	8912	351
7 Length - Counterweight to Ripper	10 136	399	10 136	399	10 136	399
8 Ground Clearance at Rear Axle	339	13.3	339	13.3	339	13.3
9 Height to Top of Cylinders	3040	120	3040	120	3040	120
10 Height to Exhaust Stack	3256	128	3256	128	3256	128
11 Width - Tire Center Lines	2140	84.3	2140	84.3	2140	84.3
12 Width - Outside Rear Tires	2511	98.9	2511	98.9	2511	98.9
13 Width - Outside Front Tires	2511	98.9	2511	98.9	2511	98.9

• Calculated with 14.0R24 Tires.

Motor Graders Specifications

Optional Tire Arrangements

Common Tire Options

140/140 AWD

Rim Size	Wheel Group	Tires
9 × 24	Single-Piece	14.0R24
13 × 25	Single-Piece	17.5R25
10 × 24	Multi-Piece	14.0R24
10 × 24	Multi-Piece	14.0-24
14 × 25	Multi-Piece	17.5R25
14 × 25	Multi-Piece	17.5-25

150/150 AWD

Rim Size	Wheel Group	Tires
9 × 24	Single-Piece	14.0R24
13 × 25	Single-Piece	17.5R25
10 × 24	Multi-Piece	14.0R24
10 × 24	Multi-Piece	14.0-24
14 × 25	Multi-Piece	17.5R25
14 × 25	Multi-Piece	17.5-25

160/160 AWD

Rim Size	Wheel Group	Tires
9 × 24	Single-Piece	14.0R24
13 × 25	Single-Piece	17.5R25
10 × 24	Multi-Piece	14.0R24
10 × 24	Multi-Piece	14.0-24
14 × 25	Multi-Piece	17.5R25
14 × 25	Multi-Piece	17.5-25

Note: Consult your dealer for individual tire width, size and brand.

Standard Equipment

Standard equipment may vary. Consult your Cat dealer for details.

POWER TRAIN

- Air cleaner, dual stage, dry type, diesel, with automatic engine derate and automatic dust ejector, service indicator through Cat Messenger
- Air-to-air after cooler (ATAAC)
- Belt, serpentine, automatic tensioner
- Brakes, oil disc, four-wheel, hydraulic
- Demand fan, hydraulic, swing-out
- Diesel exhaust fluid tank, 22.0 L (5.8 gal) ground level access, and sediment drain
- Differential Lock/Unlock, Automatic
- Drain, engine oil, ecology
- Economy mode
- Electronic over speed protection
- Engine, C9.3, U.S. EPA Tier 4 Final/ EU Stage V emission standards
- Fuel tank, 394 L (104 gal), ground level access and sediment drain
- Parking brake – multi-disc, sealed, oil-cooled
- Priming pump, fuel
- Rear axle, modular
- Sediment drain, fuel tank
- Tandem drive
- Transmission, 8F/6R, powershift, direct drive, Advanced Productivity Electronic Control Strategy (APECS)

ELECTRICAL

- Alarm, back up
- Alternator, 150 ampere, sealed
- Batteries, maintenance free, heavy duty, 1125 CCA
- Breaker panel, ground accessible
- Cab harness and electrical hydraulic valves
- Electrical system, 24V
- Grade Control Ready – Cab harness, software, electrical hydraulic valves, bosses and brackets
- Lights, roof-mounted roading, reversing, LED stop and tail
- Product Link
- Starter, electric

OPERATOR ENVIRONMENT

- Accelerator
- Air conditioning with heater
- Arm and wrist rest, electronically adjustable
- Articulation, automatic Return-to-Center
- Cat Messenger operator information system
- Centershift pin indicator
- Coat hook
- Cup holder
- Display, digital speed and gear
- Doors, left and right side with wiper
- Gauge, machine level
- Gauge cluster (analog) – fuel, articulation, engine coolant temp, engine RPM, hydraulic oil temp, regen, DEF
- Hour meter, digital
- Joystick hydraulic controls right/left blade lift with float position, circle drive, blade sideshift and tip, centershift, front wheel lean, articulation and power steering
- Joystick, adjustable armrests
- Joystick gear selection
- Joystick hydraulic power steering
- Ladders, cab, left and right side
- Lights, night time cab
- Mirror, inside rearview, wide angle
- Power port, 12V
- Radio Ready, Entertainment
- ROPS cab, sound suppressed 70 dB(A)
- Seat, cloth-covered, comfort suspension
- Seat belt, retractable 76 mm (3 in)
- Storage area for cooler/lunchbox
- Throttle control, electronic
- Windows, laminated glass:
 - fixed front with intermittent wiper
 - door with intermittent wipers (3)
- Windows: tempered
 - left and right side wipers
 - rear and intermittent wiper

FLUIDS

- Antifreeze
- Extended Life Coolant to -35°C (-30°F)

TIRES, RIMS AND WHEELS

- Partial allowance for tires on 254×607 mm (10×24 in) multi-piece rims is included in the base machine price and weight

OTHER STANDARD EQUIPMENT

- Accumulators, brake, dual certified
- Anti-glare paint
- Bumper, rear, integrated with hitch
- CD ROM Parts Book
- Clutch, circle drive slip
- Cutting edges
 - 152×16 mm ($6 \times 5/8$ in)
 - curved DH-2 steel
 - 19 mm ($3/4$ in) mounting bolts
- Doors (3), engine compartment, locking
- Drawbar – 6 shoes, replaceable wear strips
- Electrical hydraulic valves, hydraulic lines for base 8 functions
- Endbits
 - 16 mm ($5/8$ in) DH-2 steel
 - 19 mm ($3/4$ in) mounting bolts
- Fluid check, ground level
- Frame, articulated, with safety lock
- Ground level engine shutdown
- Hammer (emergency exit)
- Horn, electric
- Hydraulic lines for base functions
- Lockout, hydraulic implement (for roading and servicing)
- Moldboard
- Mounting, cab roof accessories
- Pump, hydraulic, high capacity, 98 cm^3 (6 in^3)
- Radiator, cleanout access (both sides with swing doors)
- Secondary steering
- Serviceability, LH side
- S·O·SSM ports: engine, hydraulic, transmission, coolant, fuel
- Tandem walkway/guards
- Tool box

Optional Equipment

Optional Equipment

Optional equipment may vary. Consult your Cat dealer for details.

	kg*	lb*		kg*	lb*		kg*	lb*
ELECTRICAL			POWER TRAIN			WORK TOOLS/G.E.T.		
• Alternator, 280 ampere	2	5	• All Wheel Drive	892	1,967	• Blade extension, left hand, 610 mm (2 ft)	113	249
• Batteries:			• Precleaner, snow	2	5	• Blade extension, right hand, 610 mm (2 ft)	113	249
– extreme duty, 1,400 CCA	14	30	• Starter, extreme duty, 1,000 Amps	22	48	• Counterweight	427	939
• Lights:			• Transmission, autoshift	2	5	• Cutting edges, curved	43	95
– Headlights, high	38	84				• Endbits, overlay	24	52
– Headlights, low	35	77	OTHER ATTACHMENTS			• Front lift group, mounting	5	11
– Working lights, basic	9	20	• Auto Articulate			• Front lift group, mechanical	680	1,500
– Working lights, plus, LED	10	22	• Stable Blade			• Grader bit, narrow and super penetration	181	400
– Warning: beacon or strobe	2	5	• Cat GRADE:			• Mid-Mount Scarifier, Package	917	2,017
– Mounting for warning light	5	11	– Digital Blade Slope Meter			• Moldboard		
			– Cross Slope Indicate			– 4267 mm × 610 mm	147	323
			– Cross Slope			× 22 mm (14 ft × 24 in × 7/8 in)		
GUARDS			– Cat Production Measurement			– 4267 mm × 686 mm	284	625
• Articulation guard	5	11	• AccuGrade ARO	46	101	× 25 mm (14 ft × 27 in × 1 in)		
• Fenders, front	121	266	• Integrated cross slope	47	103	160/160 AWD only:	472	1,040
• Fenders, front, AWD	56	124	• Accumulators, blade lift	55	121	– 4877 mm × 686 mm		
• Fenders, rear	156	344	• Camera, rearview	9	20	× 25 mm (16 ft × 27 in × 1 in)		
• Front axle guard	13	30	• Cat Product Link 321SR	13	29	• Push plate	1285	2,833
• Sound suppression (bottom)	110	243	• Cat Product Link 522	13	29	• Ripper, rear	1042	2,292
• Sound suppression (enclosure)	15	33	• Circle Saver	4.5	10	• Ripper tooth	28	61
• Transmission	141	311	• Drain, ecology, engine Wiggins	2	5	• Scarifier, front	434	956
			• Heater, engine coolant:			• Snow Arrangement	161	355
			– 120V	1	3	• Snow Wing Ready Package	119	262
			– 240V	1	3	• Tow hitch	53	116
OPERATOR ENVIRONMENT			• Hydraulic arrangements with one or more additional hydraulic valves are available for rear ripper, dozer, snow plow and snow wing.			MACHINE ARRANGEMENTS		
• Mirrors, outside:			• Snow wing mounting, frame ready	91	200	• Canadian Arrangement	2	4
– heated 24V	15	33	• Starting aid, ether	0.5	1	• European Arrangement	289	637
– mounted	15	33	• Reversing fan, automatic or manual	6	13	• TUV Rooding Arrangement	451	994
• Comfort Plus Arrangement	2	4						
• Comfort Premium Arrangement	3	7						

*Weights shown are to be added to the standard configuration when option is chosen.

BID SPECIFICATIONS

Cat® 150 (15A) JOY Motor Graders BID SPECIFICATIONS

AEXQ3805 (02-2024)

BASIC SPECIFICATIONS

- Y___ N___ Machine shall be designed and built by the manufacturer.
- Y___ N___ Base machine weight shall not be less than 38,191 lbs (17 323 kg). Weight shall include standard machine configuration, lubricants, coolants, full fuel tank and operator of 200 lbs (91 kg).
- Y___ N___ Machine height to top of the cab shall not exceed 130 in (3308 mm).
- Y___ N___ Machine length from the front outside edge tire to end of tow hitch shall not be less than 351 in (8912 mm).
- Y___ N___ Machine wheel base (distance from front axle to mid tandem) shall not be less than 241 in (6123 mm).
- Y___ N___ The rear frame shall have two box section channels with an integrated bumper as standard.
- Y___ N___ A toolbox shall be provided.

BASIC SPECIFICATIONS - OPTIONAL ATTACHMENTS

- Y___ N___ Machine shall have vandal protection standard including locks for cab doors, engine side shields (4), top tank radiator access door, engine coolant surge tank, hydraulic reservoir cap, fuel tank cap, and tool box.
- Y___ N___ An optional rear hitch shall be provided.
- Y___ N___ Machine length from counterweight to ripper shall not exceed 399 in (10 136 mm).

ENGINE

- Y___ N___ Engine shall be designed and built by the manufacturer.
- Y___ N___ Engine shall be a turbo-charged, direct injection, four stroke, 6-cylinder diesel engine.
- Y___ N___ Engine shall be certified EPA Tier 4 Final and European Union Stage IV.
- Y___ N___ Engine shall be electronically controlled for more efficient fuel injection and fuel burn.
- Y___ N___ Engine shall achieve rated power requirement with engine displacement not less than 9.3L (568 in³) for better performance and fuel economy.
- Y___ N___ Engine shall develop as standard a rated net flywheel power of at least 200 HP (149 kW) in 1st gear, 210 HP (156 kW) in 2nd gear, 220 HP (164 kW) in 3rd gear, 231 HP (172 kW) in 4th gear, 236 HP (176 kW) in 5th gear, 241 HP (180 kW) in 6th gear, 247 HP (184 kW) in 7th gear, and 252 HP (188 kW) in 8th gear.
- Y___ N___ Engine will increase its low idle speed to 1,000 rpm when the battery voltage is below 24.5 volts for more than 5 minutes to ensure adequate system voltage and battery reliability.
- Y___ N___ Altitude deration will not occur at altitudes less than 10,000 ft (3050 m). The deration rate above 10,000 ft (3050 m) shall be 1.5% per 1000 ft (305 m).
- Y___ N___ Peak engine power shall not be achieved at an engine speed greater than 1800 rpm.
- Y___ N___ Rated engine power shall not be achieved at an engine speed greater than 2000 rpm.
- Y___ N___ Engine will have an minimum torque rise of 47% from 2000 rpm to peak torque following SAE J1349 (net power with max fan).
- Y___ N___ Engine enclosure and daily service points shall be accessible from ground level and grouped on the left side of the machine.
- Y___ N___ Engine fan shall automatically adjust fan speed via a variable hydraulic fan pump to meet engine cooling requirements thus reducing demand on the engine, putting more horsepower to the ground, reducing noise, improving fuel economy, and reducing heat.
- N___ **Engine shall allow for at least 1000 hours of operation between engine oil and engine oil filter changes (with SOS sampling).**
- Y___ N___ Engine shall be isolation/resilient mounted to minimize sound and vibration.
- Y___ N___ Engine compartment doors shall be lockable without the use of external locks.

BID SPECIFICATIONS

- Y___ N___ Engine shall automatically lower engine torque and alert the operator if critical conditions are detected.
- Y___ N___ Engine shall have an air-to-air after cooler for superior engine performance.
- Y___ N___ Engine oil cooler shall be a water to oil shell and tube cooler system.
- Y___ N___ Machine shall have a 12000 hour coolant interval from factory.
- Y___ N___ The cooling package air intake shall have 2.8 mm perforated inlet screen.
- Y___ N___ The charged air cooler (ATAAC) shall have 6 fins per inch.
- Y___ N___ Economy mode shall be available directly from factory to increase net efficiency.
- Y___ N___ Economy mode shall be able to be enabled and disabled by the operator through the onboard message display.
- Y___ N___ Economy mode shall be lockable via onboard programmable password protection.
- Y___ N___ DEF tank reservoir shall have a heater to thaw DEF fluid.
- Y___ N___ DEF lines should be heated to prevent freezing during extremely cold ambient conditions.

ENGINE - OPTIONAL ATTACHMENTS

- Y___ N___ An engine coolant heater shall be available to assist in cold weather starting.
- Y___ N___ Ether starting aid shall be available and must automatically meter ether injection to prevent
- Y___ N___ Reversing hydraulic fan shall be available for high debris applications and environments.

POWERTRAIN / TRANSMISSION

- Y___ N___ Transmission shall be designed and built by the machine manufacturer.
- Y___ N___ Transmission shall be a direct drive, power shift, countershaft type.
- Y___ N___ Transmission shall be equipped with built-in self-diagnostic capability.
- Y___ N___ Transmission shall have no less than 8 forward speeds and 6 reverse speeds (for added safety).
- Y___ N___ Transmission shall have 5 working gears between 0-10.6 mph (0-17.1 km/h), for dirt applications.
- Y___ N___ Transmission shall be isolated/resilient mounted to reduce sound and vibration.
- Y___ N___ A controlled throttle shifting system shall be standard to smooth directional gear changes without use of the inching pedal.
- Y___ N___ Electronic throttle control (cruise control) shall be standard and shall be controlled by a push button, located on a 3-axis joystick as standard on the right joystick control for resuming and
- Y___ N___ Electronic throttle control modes, set and accelerate functions, shall be located on the right control column for easy access.
- Y___ N___ A load compensating system for the transmission shall be standard to ensure consistent shift quality in all applications.
- Y___ N___ Automatic differential lock / unlock feature shall be standard and shall not have speed, shuttle shifting or tandem spinning restrictions for engaging/disengaging. System must be load-sensing
- Y___ N___ Automatic mode shall not be overridden via manual intervention for optimal performance and to prevent unintended differential engagement
- Y___ N___ Differential Lock/Unlock shall be electro-hydraulically controlled, as a standard feature.
- Y___ N___ Differential Lock/Unlock shall be a multi-disc design.
- Y___ N___ Final drive shall be a planetary design.
- Y___ N___ The rear axle shall be a bolt-on modular design offering easy access to differential components, improving serviceability and contamination control.
- ~~Y~~___ ~~N~~___ **The total surface area of all the transmission clutch packs shall not be less than 1831 in²**
- ~~Y~~___ ~~N~~___ **Diameter at the output end of the transmission shaft shall be no less than 2.29 in (58.1 mm).**
- Y___ N___ Machine shall be equipped with an electronic inching pedal for improved modulation and machine control.

BID SPECIFICATIONS

- Y N Machine shall be equipped with electronic over-speed protection to prevent the engine and transmission from over speeding, as a standard feature.
- Y N Machine shall have no drive shafts that cross over the articulation hitch.

POWERTRAIN / TRANSMISSION - OPTIONAL ATTACHMENTS

- Y N An autoshift transmission option shall be available on all forward and reverse gears.

STEERING AND IMPLEMENT CONTROLS

- Y N Steering wheel shall not be required to operate machine.
- Y N Joystick Steering capabilities shall be ISO 5010:1992.
- Y N Machine shall employ a friction pack style steering mechanism, utilizing the speed sensitive follow steer concept.
- Y N The left 3-axis joystick shall control wheel lean with individual left and right wheel lean buttons as standard.
- Y N Primary steering shall be achieved via a left-hand, multifunction, 3-axis joystick as standard, using an intuitive steering control system that automatically adjusts steering sensitivity as
- Y N Articulation to the right or left shall be achieved by a multifunction, 3-axis left joystick with the twist of such to the right or left by the left-hand, multifunction, 3-axis joystick.
- Y N An articulation return-to-center button on the left-hand, multifunction, 3-axis joystick shall return the machine to a straight frame position from any articulation angle with the touch of a single button.
- Y N The right 3 axis joystick shall primarily control the drawbar, circle, and moldboard.
- Y N Machine, drawbar, circle, and moldboard shall be control shall be achieved via a right hand multifunction, 3-axis, joystick, including moldboard slide and tip, drawbar center shift through a 4 way hat switch and circle turn by a left or right twist intuitively.
- Y N Blade lift cylinders shall be individually controlled by the multifunction, 3 axis joysticks; Lift and drop of cylinders shall be achieved by the forward and back motion of the respective joystick. Forward (left joystick) lowers left lift cylinder, back (left joystick) raises the left lift cylinder, forward (right joystick) lowers the right lift cylinder, back (right joystick) raises the right lift cylinder.
- Y N Joystick controls shall be mounted to electronically adjustable pedestals, which are hard mounted to the cab floor, independent of the operator seat.
- Y N Secondary steering shall have a primary and secondary power supply in the event the primary
- Y N Transmission direction control shall be a 3-position rocker switch for selecting forward, neutral, and reverse incorporated into a single, 3-axis, multi-function, left-hand joystick control.
- Y N Transmission gear selection shall be controlled by dual push buttons for up shifting and downshifting and shall be incorporated into a single, 3-axis, multi-function, left-hand joystick control.
- Y N Manual Differential Lock/Unlock shall be operator controlled, via a push-button, located on a single, 3-axis, multi-function, right-hand joystick control.
- Y N The machine shall have two redundant articulation sensors.
- Y N Two redundant sensors shall be standard in the steering cylinders (one in each).
- Y N Three redundant sensors shall be provided in the steering joystick for additional safety.
- Y N Machine shall have auto articulation available to allow the operator to automatically articulate with a steering input. The rear wheels will automatically follow the front wheel. The system is activated by a three position switch: Off, On- forward and reverse, or On - forward only. The system improved maneuverability and performance in tight work space or for easy turn arounds.

BRAKES

- Y N Machine shall have primary and secondary service brakes.

BID SPECIFICATIONS

- Y ___ N ___ Entire braking system shall meet all requirements of ISO 3450:1996.
- Y ___ N ___ Two separate left and right hydraulic brake accumulators shall be standard for safety.
- Y ___ N ___ Parking brake shall be multi-disc, oil-cooled, spring-applied, hydraulically released, sealed, adjustment-free, and integrated into the transmission. Park brake shall not be externally located.
- Y ___ N ___ Parking brake shall be serviceable without removing the transmission.
- Y ___ N ___ Service brakes shall be multi-disc, oil-cooled and completely sealed; they will also provide access to check and determine brake wear without removing or disassembling the brake assembly.
- Y ___ N ___ Service brake disc surfaces shall be grooved and carry oil between discs and plates with brakes
- Y ___ N ___ Service brakes shall be hydraulically actuated, utilizing dual independent brake circuits.
- Y ___ N ___ Brakes shall be continuously pressurized, filtered, oil cooled.
- Y ___ N ___ Machine shall have individual brake pods for each rear wheel, located at each rear wheel inside the tandem box, independent of tandem chains.
- Y N ___ **Compensation components shall be required at all four tandem brake pods in addition to the brake wear indicator.**
- Y ___ N ___ Brake line protection, including tandem walkways and hydraulic brake line guarding, shall be required to prevent line damage.
- Y N ___ **Service brakes shall provide a minimum of 620 in² (4003 cm²) of friction material surface area at each of the four tandem wheels to eliminate braking loads on the power train.**

HYDRAULIC SYSTEM

- Y ___ N ___ A standard triple-redundant hydraulic relief system shall protect machine hydraulic components.
- Y ___ N ___ Hydraulic implement pump shall produce between 0 and 55.0 gal/min (210 L/min) of oil flow at 1,800 RPM.
- Y ___ N ___ Hydraulics system shall be a closed center, load sensing type with a variable displacement, axial piston-type pump.
- Y ___ N ___ Hydraulic system shall be fully sealed, using duo-cone and O-ring face seals to prevent leaks, contamination, and spillage.
- Y ___ N ___ The hydraulic tank shall have a baffling system to reduce potential pump cavitation.
- Y ___ N ___ The maximum hydraulic system pressure shall be no more than 3,500 psi (24,150 kPa).
- Y ___ N ___ Implement valves shall be electro-hydraulic, designed and built by the machine manufacturer.
- Y ___ N ___ Implement pump shall not be mounted under cab floor, minimizing sound and vibration.
- Y ___ N ___ Implement valves shall be proportional priority pressure compensating for consistent response when multi-functioning any combination of implement controls and independent of engine speed.
- Y ___ N ___ Implement pump shall be solely dedicated to implement controls and not shared with any other
- Y ___ N ___ Lock valves shall be integrated into the main implement valve to prevent cylinder drift.
- Y ___ N ___ The hydraulic stand-by pressure shall be no more than 885 psi (6100 kPa) at 1,800 RPM.
- Y ___ N ___ There shall be a provision to install up to 15 modulating hydraulic valves, controlled by two multifunction, 3-axis joystick controls and auxiliary controls inside the cab.
- Y ___ N ___ Hydraulic valves shall not be mounted under the cab floor, minimizing sound and vibration.
- Y ___ N ___ Left and right blade lift cylinders shall have independent float capability, actuated by two multifunction, 3-axis joystick controls inside the cab, as a standard feature.
- Y ___ N ___ A sight gauge will be provided for checking hydraulic reservoir fluid.
- Y ___ N ___ Hydraulic oil change service interval shall be no less than 6000 hours with oil sampling.
- Y ___ N ___ Hydraulic system shall have a separate oil tank solely dedicated to the implement pump.
- Y N ___ **Hydraulic filter shall have 1000 hour change filter interval.**

BID SPECIFICATIONS

FRONT AXLE AND TANDEMS

- Y ___ N ___ Front axle oscillation shall be no less than 32 degrees total, per side 16 degrees up and 16 degrees down.
- Y ___ N ___ Front axle shall be an arched design for maximum ground clearance.
- Y ___ N ___ Wheel spindle shall be a "live" spindle design and rotate inside a sealed (with duo-cone seals) compartment with lightweight oil for lubrication of the bearings.
- Y ___ N ___ Front spindle shall be heat induction hardened.
- Y ___ N ___ Front wheel spindle bearings shall be a double-tapered design with the larger diameter bearing mounted closest to the centerline of the front tire.
- Y ___ N ___ Front wheel spindle maintenance intervals shall be no less than 2000 hrs.
- Y ___ N ___ Front wheel steering angle shall be no less than 50.0 degrees left or right.
- Y ___ N ___ Maximum front wheel lean shall be no less than 18 degrees left or right.
- Y ___ N ___ Machine turning radius shall not exceed 25 ft. 7 in. (7.8 m) using front steering, full articulation and unlocked differential.
- Y ___ N ___ Distance between center of tandem wheels shall be no greater than 60.0 in (1523 mm) for optimum clearance and mobility.
- Y ___ N ___ Tandem drive chain pitch shall not be less than 2.0 in (50.8 mm).
- Y ___ N ___ Tandems shall be capable of oscillating 15 degrees front tandem up and 25 degrees front tandem down, with full machine articulation and having no interference between tandem wheel and machine structure.
- Y ___ N ___ Electronic and mechanical steering stops located at each wheel and steering cylinder relief valves shall be present to prevent steering system damage during normal operation.
- Y ___ N ___ Steering tie rod ends shall be heat induction hardened.
- Y ___ N ___ Machine shall provide 2 steering cylinders for maximum steering force.
- Y ___ N ___ When equipped with a ripper, the machine shall have a minimum ramp angle of 15.9 degrees.

TIRES AND RIMS

- Y ___ N ___ A 10 in (25.4 cm) by 24 in (60.96 cm) size 3-piece tire rim shall be standard to provide mounting for 14.00-24 tires and 14.00R24 conventional tires.

TIRES AND RIMS-OPTIONAL ATTACHMENTS

- Y ___ N ___ A 9 in (22.86 cm) by 24 in (60.96 cm) size single-piece tire rim shall be available to provide mounting for a 14.00R24 conventional tires
- Y ___ N ___ A 13 in (33.0 cm) by 25 in (63.5 cm) size single-piece tire rim shall be available to provide mounting for 17.5-25 tires.
- Y ___ N ___ A 14 in (35.6 cm) by 25 in (63.5 cm) size 3-piece tire rim shall be available to provide mounting for 17.5-R25 tires.

OPERATORS STATION

- Y ___ N ___ A 42,075 BTU/h (12.3 kW) heater shall have an integral pressurizer and four-speed fan along with A/C.
- Y ___ N ___ Cab shall have angled floor design allowing direct visibility to moldboard.
- Y ___ N ___ Seat shall be a cloth-covered suspension seat with 3 in (76 mm) retractable seat belts, with adjustments for fore-aft position, seat height, seat back angle, thigh support, and lumbar support.
- Y ___ N ___ An enclosed cab with ROPS (Rollover Protective Structure) according to ISO 3471:1986-
- Y ___ N ___ Cab doors shall have a hold-open clasp with a ground-level release in addition to a release in the cab.
- Y ___ N ___ Cab shall be isolation-mounted to the front frame section of the machine.
- Y ___ N ___ Cab shall have fixed front window of laminated glass with intermittent wiper.
- Y ___ N ___ FOPS (Falling Object Protective Structure) shall be provided according to ISO 3449.

BID SPECIFICATIONS

- Y ___ N ___ Machine shall have no less than 17 adjustable vents, positioned to direct air to front windows and operator.
- Y ___ N ___ Radio ready arrangement will include 24 V to 12 V converter, two speakers, antenna, and wiring.
- Y ___ N ___ An instrument cluster shall be provided that includes a speedometer, tachometer, coolant temperature, fuel and articulation angle gauge.
- Y ___ N ___ Operator cab fresh air-filter shall be accessible for clean out and replacement, from outside of the cab at ground level.
- Y ___ N ___ Machine shall have the Cat Grade system fully integrated into the machine design with integral hydraulic and electrical components.
- Y ___ N ___ A real-time information system shall monitor all system data and alert the operator of any faults through a digital text display. This performance and diagnostic information system shall be programmable for multiple languages .
- Y ___ N ___ Left and right side cab doors shall be provided.
- Y ___ N ___ Wipers shall be provided on side and rear windows.
- Y ___ N ___ Digital machine hour meter shall be provided.
- Y ___ N ___ An electronic message system shall provide real-time machine performance and diagnostic data.
- Y ___ N ___ The forward visibility shall be continuous and unobstructed glass from roofline to floor providing visibility of the blade, heel and toe, back of the cutting edge, and front tires.
- Y ___ N ___ Access to cab shall be three anti-skid steps.
- Y ___ N ___ Cab shall have cup holder, personal cooler holder/storage compartment for operator's manual, with a molded floor mat.
- Y ___ N ___ Window washer fluid bottle refill spout shall be located external of the cab.
- Y ___ N ___ DEF gauge must be visible to the operator at all times.

OPERATORS STATION - OPTIONAL ATTACHMENTS

- Y ___ N ___ **Manufacturer must provide Stable Grade sensor and software to automatically reduce engine speed in various applications to reduce machine bounce and scalloping of surface**
- Y ___ N ___ An auxiliary control pod, with implement float control capability, shall be available.
- Y ___ N ___ Auxiliary controls shall be available for control of attachment implements and/or work tools and shall be programmable via computer software.
- Y ___ N ___ Auxiliary controls shall be a finger-tip control type and located beside the right-hand joystick control.
- Y ___ N ___ An auxiliary, 2-axis joystick shall be available for control of a snow wing.
- Y ___ N ___ Integrated Cross Slope System shall be available from the factory in order to ensure proper calibration and installation for improved accuracy and performance.
- Y ___ N ___ Integrated display and wiring for a rear vision camera shall be available with capability to view at all times without interfering with the gauge and diagnostic display.
- Y ___ N ___ A rear sun shade shall be available.
- Y ___ N ___ A rear defroster fan shall be available.
- Y ___ N ___ A machine security system shall be available to electronically code keys selected by the user to limit usage by individuals or by time parameters.
- Y ___ N ___ Cat Grade Attachment Ready Option (ARO) shall be available from the factory. This option shall include additional mounting brackets and electrical harnesses for easy installation of the electronics kit.
- Y ___ N ___ An air suspension seat shall be available.
- Y ___ N ___ Anti-icing glass shall be available for front windshield and RH door.
- Y ___ N ___ A heated or both heated/ventilated seat shall be available.
- Y ___ N ___ Machine shall have integrated Cat Grade Control Cross Slope Auto available from the factory.

BID SPECIFICATIONS

- Y N **Cross slope display shall include actual slope, target slope and machine mainfall on the same display screen.**
- Y N **Cross slope system shall have up to 9 slope target presets programmable by the operator.**
- Y N Machine shall have an integrated cross slope system that is fully upgradeable to other 2D/3D
- Y N **Machine shall have a display for cross slope information that is separate from critical machine information such as engine RPM, ground speed and fluid temperature**
- Y N **Machine shall have Digital Blade Slope Meter available from the factory.**
- Y N **Machine shall have integrated 3D mastless system available from the factory.**

CIRCLE AND MOLDBOARD

- Y N Drawbar, circle, and moldboard shall be controlled with a maximum of two multifunction, 3-axis joysticks, as standard.
- Y N **Drawbar wear strips shall be replaceable drop-in inserts made from nylon composite material, replaceable and adjustable from the top of the drawbar plate via removable cover plates.**
- Y N The drawbar shall feature welded protective wear plates to prevent lift group contact with the primary drawbar structure.
- Y N The standard moldboard shall be at least 12 ft (3657 mm) long, 24 in (610 mm) high and no less than 7/8 in (22 mm) thick.
- Y N Moldboard shall have a bank slope angle capability of at least 90 degrees to both sides.
- Y N Moldboard side-shift cylinder shall be installed on the left-hand side to prevent snow wing interference with the cylinder rod.
- Y N Moldboard shall have no less than 16.3 in (413 mm) arc radius (blade curvature) for optimum productivity.
- Y N The moldboard retention system shall have no more than two retention points located on the left and right side of the moldboard. The surface area shall not be less than 50 408 mm² (78.13 in²).
- Y N Moldboard shall have a hydraulic tip control through a range of 40 degrees fore and 5 degrees aft.
- Y N Moldboard wear strips shall be adjusted with lock screws, providing shim-less adjustment capability both vertical and horizontal.
- Y N The moldboard shall be pre-stressed during manufacturing for superior strength and durability.
- Y N Moldboard slide rails shall be constructed of a heat-treated, high carbon steel and have replaceable bronze alloy wear inserts on top and bottom.
- Y N Circle shall be a single piece, rolled-ring forging with raised wear surfaces on the top and bottom.
- Y N Circle shall be rotated by a hydraulically driven motor (pinion gear) with a minimum circle pinion torque capability of 44253 ft-lb (60,000 N-m).
- Y N Circle teeth contact surfaces shall be induction-hardened on the front 240 degrees of the circle.
- Y N Blade lift and center shift cylinders shall have replaceable bronze-alloy wear inserts in the ball sockets with removable shims to insure the ability to remove free play throughout the useful wear insert life.
- Y N The lift cylinder casting shall be welded to the front frame for added strength and structural integrity.
- Y N The standard mounting hardware for cutting edges and end bits shall be 3/4 in (19 mm)
- Y N All 7 Link Bar positions have replaceable bushings.
- Y N Linkbar pin shall be separate from pin pulling mechanism for easier service and lower O&O costs.
- Y N The draft frame pivot connection shall have a single ball stud with grease fitting. Ball stud shall be bolt-on, shimable and adjustable to allow for quick and easy field serviceable design.

BID SPECIFICATIONS

- Y N ___ **There shall be 3 sideshift anchor positions shall be provided for extended reach capability as standard on 14 foot moldboard.**
- Y N ___ **Pinion gear shall be separate from the pinion shaft to allow for a quick and easy**
- Y ___ N ___ Circle outside diameter shall be no less than 60.2 in (1530 mm).
- Y ___ N ___ Throat clearance with standard moldboard shall be at least 153 mm.
- Y ___ N ___ There will be no more than 6 replaceable wear inserts between the circle and drawbar providing at least 163 in² (1051 cm²) of wear surface area.

CIRCLE AND MOLDBOARD - OPTIONAL ATTACHMENTS

- Y ___ N ___ A 14 ft (4267 mm) long, 24 in (610 mm) high and no less than 7/8 in (22 mm) thick moldboard shall be available.
- Y ___ N ___ A 14 ft (4267 mm) long, 27 in (686 mm) high and no less than 1 in (25 mm) thick moldboard shall
- Y ___ N ___ Blade lift accumulators shall be provided, protecting cutting edge and other components from damage from shock loads as an option.
- Y ___ N ___ 2 foot, right hand blade extension share by available for all moldboards.
- Y ___ N ___ 2 foot, left hand blade extension share by available for all moldboards.
- Y N ___ **Optional Circle Saver (pinion grease system) for easier maintenance shall be available from the factory.**

ELECTRICAL

- Y ___ N ___ Machine shall have a 145 amp-hour, 1125 CCA heavy-duty battery.
- Y ___ N ___ Machine shall have a minimum 150-amp alternator at 24 volts provided which is brushless for increased life and durability.
- Y ___ N ___ Six 3 x 3 in (76 x 76 mm) halogen mounted cab lights shall be provided.
- Y ___ N ___ A 24 V to 12 V converter with 10-amp capacity shall be provided.
- Y ___ N ___ Starting system shall be a 24V direct electric type.
- Y ___ N ___ LED white reversing lamps and LED stop lamps shall be provided.
- Y ___ N ___ Electrical system shall have a master disconnect switch with a removable key (in addition to the ignition switch), accessible from the ground level.
- Y ___ N ___ All core machine systems shall be electronically connected, optimizing performance and preventing machine damage.
- Y ___ N ___ All wiring shall be arranged and located so as to facilitate regular visual inspections, not be in contact with hot surfaces and not routed with other services lines (fuel and oil).
- Y ___ N ___ All harnesses / cabling are secured with clipping clamps providing a gap between the conduit/harness and the mounting surface preventing material build-up.
- Y ___ N ___ Power must remain available upon key off to purge DEF system lines and protect components.

ELECTRICAL - OPTIONAL ATTACHMENTS

- Y ___ N ___ Machine shall have 200 amp-hour, 1400 CCA extreme duty batteries available.
- Y ___ N ___ Machine shall have a 280-amp alternator at 24 volts available which is brushless for increased life and durability.
- Y N ___ **Drop down lights shall be available to move LED stop lamps out to the width of the machine.**
- Y ___ N ___ Six 3 x 3 in (76 x 76 mm) halogen mounted cab lights shall be provided.
- Y ___ N ___ Six 3 x 3 in (76 x 76 mm) LED mounted cab lights shall be available.
- Y ___ N ___ There will be 2 (3 x 3 in) (76 x 76 mm) halogen mounted on the right-hand side of cab roof bar to illuminate a snow wing shall be available.
- Y ___ N ___ There will be 2 (3 x 3 in) (76 x 76 mm) LED mounted on the right-hand side of cab roof bar to illuminate a snow wing shall be available.
- Y ___ N ___ There will be 2 (3 x 3 in) (76 x 76 mm) halogen heel work lamps mounted underneath the cab shall be available as an option.

BID SPECIFICATIONS

- Y___ N___ There will be 2 (3 x 3 in) (76 x 76 mm) LED heel work lamps mounted underneath the cab shall be available as an option.
- Y___ N___ There will be 2 (3 x 3 in) (76 x 76 mm) halogen mid-frame toe lamps shall be available to illuminate moldboard and surrounding area as an option.
- Y___ N___ There will be 2 (3 x 3 in) (76 x 76 mm) LED mid-frame toe lamps shall be available to illuminate moldboard and surrounding area as an option.
- Y N___ **There will be 2 (3 x 3 in) (76 x 76 mm) halogen ripper work lamps shall be available as an option.**
- Y N___ **There will be 2 (3 x 3 in) (76 x 76 mm) LED ripper work lamps shall be available as an option.**
- Y___ N___ High and low bar halogen headlights with front turn signals shall be available.
- Y___ N___ High and low bar LED headlights with front turn signals shall be available.
- Y___ N___ An amber LED high-speed strobe beacon shall be available.
- Y___ N___ 24 V to 12 V converter with 25 amp capacity shall be available.

SERVICEABILITY

- Y N___ **Machine shall have a lockable swing-out cooling fan housing featuring a latch-style mechanism (shall not be of a bolted design), allowing easy access to cores. Ability to open/close shall be ground level accessible, eliminating need to climb on machine.**
- Y___ N___ The dip stick for checking transmission fluid shall be at ground level.
- Y___ N___ Hydraulic tank site gauge shall be readable from the ground.
- Y___ N___ Hydraulic tank filter shall be a cartridge style filter providing a separate filter element, housing, and drain valve for quick and clean servicing.
- Y___ N___ Ability for ground level fueling shall be provided.
- Y___ N___ Sampling ports shall be accessible from the tandem level and provide access to the engine, hydraulic, coolant, and fuel ports.
- Y___ N___ A two-way communication tool shall give service technicians easy access to stored diagnostic data and allow configuration of machine parameters.
- Y___ N___ Machine shall provide 3 points of contact on all areas of the machine, for mounting and dismounting.
- Y___ N___ The articulation joint shall have mechanical locking device to prevent frame articulation while servicing or transporting machine.
- Y___ N___ Left and right side tandem case assemblies shall be covered with punched steel plate to provide an adequate platform for standing and walking.
- Y___ N___ Sampling ports shall be accessible from the tandem level and provide access to the engine, hydraulic, coolant, and fuel ports.
- Y___ N___ **Engine primary and final fuel filters shall have 1000 hour service replacement interval with fluid sampling.**
- Y___ N___ Engine shall have primary fuel filter with fuel water separator and electronic sensor, quick release dual stage filter and primer pump.
- Y___ N___ **Engine oil filter shall be a 1000 hour change interval, cartridge style filter.**
- Y___ N___ **Engine primary and final fuel filters shall have 1000 hour service replacement interval.**
- Y N___ **Engine shall have primary fuel filter with water in filter (wif) sensor, quick release dual stage filter and primer pump.**
- Y N___ **Cartridge style filters (engine oil filter, fuel filters) shall have ability to drain filter canisters prior to removal for cleaner and easier filter changes.**
- Y___ N___ The centralized lube bank shall be at the articulation joint to give access to difficult fittings.
- Y___ N___ Transmission filter restriction indicator shall be displayed in the cab.

BID SPECIFICATIONS

- Y ___ N ___ Lock out / tag out capabilities shall be provided standard and increase the safety levels during down time. This ensures that an energy isolating device and the machine which are being worked on and cannot be operated.
- Y ___ N ___ DEF tank fill shall be located on the same side of the fuel tank fill, and be easily accessible from ground level.

SERVICEABILITY - OPTIONAL ATTACHMENTS

- Y ___ N ___ A guard shall be available to protect the machine's transmission from debris.
- Y ___ N ___ A guard shall be available to suppress sound from the engine.
- Y ___ N ___ **Option Circle Saver shall be provided for easy daily maintenance of the circle pinion.**
- Y ___ N ___ Reversing hydraulic fan shall be available for high debris applications and environments.
- Y ___ N ___ Engine compartment and hydraulic oil tank sight gauge service light shall be available.

MINIMUM SERVICE FILL CAPACITIES

- Y ___ N ___ Standard fuel tank capacity shall not be less than 104 gallons (394 L).
- Y ___ N ___ Standard cooling system capacity shall not be less than 15.0 gallons (57.0 L).
- Y ___ N ___ Standard hydraulic tank capacity shall not be less than 16.9 gallons (64.0 L).
- Y ___ N ___ Standard engine oil capacity shall not be less than 7.9 gallons (30.0 L).
- Y ___ N ___ Standard tandem housing capacity shall not be less than 20.0 gallons (76.0 L) each.
- Y ___ N ___ Standard front wheel spindle bearing housing capacity shall not be less than 0.13 gallons (0.5 L).
- Y ___ N ___ Standard circle drive housing capacity shall not be less than 1.8 gallons (7 L).
- Y ___ N ___ Standard DEF tank capacity shall not be less than 5.8 gallons (22 L).

SAFETY AND ENVIRONMENTAL

- Y N ___ **A circle drive slip clutch shall be provided to reduce horizontal moldboard impact damage.**
- Y N ___ **An external emergency kill switch shall be available for ground level engine shut down.**
- Y N ___ **Secondary, electric steering pump shall be provided as a backup to the primary implement hydraulic pump.**
- Y ___ N ___ Black glare-reducing paint shall be used on the front frame and engine enclosure to decrease glare from other equipment lights and reflection from the sun and snow.
- Y N ___ **Operator not present monitoring system will lockout implements, shall not allow gear shift out of neutral, and lock parking brake if system detects operator not present for increased safety.**
- Y ___ N ___ Hydraulic implement lockout shall be achieved by actuating a single electrical switch within the operator station.
- Y ___ N ___ Machine shall have laminated glass for the front windows and doors, to protect the operator from shattered glass.
- Y ___ N ___ Machine shall provide dual exits allowing for emergency egress should one side become obstructed.
- Y ___ N ___ Electrical system shall have a master disconnect switch with a removable key and lock for added safety. (in addition to the ignition switch).
- Y ___ N ___ Machine shall have a steering software system shall automatically reduce steering sensitivity as the ground speed increases.
- Y ___ N ___ Machine shall have back-up lights and sounding alarm when reverse gears are selected.
- Y ___ N ___ Environmentally friendly drain valves shall be provided for the hydraulic oil, engine oil, engine coolant, transmission, differential, and fuel tank.
- Y ___ N ___ Cooling fan shall have both a shroud and rear grill for protection during service.
- Y ___ N ___ Machine shall allow cab interior and exterior lights to remain on separate from ignition switch, for safe exit of the machine during night operation.

BID SPECIFICATIONS

- Y___ N___ Engine and transmission shall be rubber isolation mounted to reduce noise and vibration.
Y___ N___ Rear vision camera with integrated display and wiring shall be provided.

SAFETY AND ENVIRONMENTAL - OPTIONAL ATTACHMENTS

- Y___ N___ A guard shall be available to protect the machine's transmission from debris.
Y___ N___ Blade lift accumulators shall be available as an option to reduce vertical impact damage.
Y___ N___ Drop down rear lights (stop/turn signal lights) shall be available to span the profile of the machine for increased safety.
Y___ N___ Outside mounted mirrors (optional heated) shall be available.
Y___ N___ A engine compartment light shall be available.
Y___ N___ A seatbelt indicator sensor and light shall be available.

ADDITIONAL FEATURES

- Y___ N___ Rear ripper shall have 5 ripper shank holders and 9 scarifier shank holders.
Y___ N___ Rear ripper shall have a working penetration of maximum 16.8 in (428 mm) and a penetration force of at least 20,693 lb (9386 kg).
Y___ N___ Rear fenders shall meet ISO-3457 requirements and shall not interfere with the ability to fully open any cab/engine enclosure or service access doors.
Y___ N___ All core machine systems shall be electronically connected optimizing performance and preventing machine damage.
Y___ N___ Machine shall have no drive shafts that cross over the articulation hitch.

OPTIONAL ATTACHMENTS

- Y___ N___ Machine shall have an optional reversing fan available to reduce cooling system maintenance in high debris applications.
Y___ N___ An integrated communication tool providing flow of vital machine data and location shall be available. This system shall give automatic updates on machine parameters such as machine hours, machine condition, location, fault codes and alarms.
Y___ N___ Machine shall have a engine coolant circulating heater available.
Y___ N___ Machine shall have a transmission solenoid valve guard available.
Y___ N___ A front scarifier and mid-mount scarifier shall be available.
Y___ N___ A front lift group shall be available.
Y___ N___ A rear ripper/scarifier shall be available.
Y___ N___ A snow wing frame ready option shall be available.
Y___ N___ Rear fenders option shall be available.
Y___ N___ Front fenders option shall be available.

Bid specs are intended for use by North American buyers only and are subject to change. Model configuration may change depending on country of use. Please contact your local Caterpillar dealer for the most up-to-date specifications for your area.

Effective with sales to the first user on or after June 1, 2015

CATERPILLAR LIMITED WARRANTY

For Selected Machine Models Designated by Caterpillar with 12 Month/Unlimited Hour Warranty

Worldwide

Caterpillar Inc. or any of its subsidiaries ("Caterpillar") warrants the following products sold by it to be free from defects in material and workmanship:

- New earthmoving, construction, material handling, forestry product, paving product, compact wheel loader, mini hydraulic excavator, skid steer loader, multi terrain loader, and compact track loader machines designated by Caterpillar as having 12-months/unlimited hour warranty. See your Cat® dealer for a complete listing of covered models.

- Attachments/work tools installed on such machines prior to delivery (unless covered by the Cat Work Tool warranty statement or another manufacturer's warranty). Hammer tool points and compacting plates used on hydraulic hammers are not warranted.

An additional warranty against breakage is applicable to certain Cat ground engaging tools. An additional warranty against wear is applicable to all landfill compactor tips when used in residential waste landfills. Refer to the applicable warranty statements for coverage detail.

This warranty does not apply to:

- Cat Batteries
- Mobil-trac belts, rubber tracks used on multi terrain loaders, compact track loaders, and mini hydraulic excavators
- Cat Work Tools
- Select models designated by Caterpillar that are sold in India and China

These products are covered by other Caterpillar warranties. This warranty is subject to the following:

Warranty Period

For new machines and work tools/attachments the warranty period is 12-months/unlimited hours, starting from date of delivery to the first user.

Note:

- For hydraulic line's quick connect/disconnect components sold on compact wheel loaders, mini hydraulic excavators, skid steer loaders, multi terrain loaders, and compact track loader machines, the warranty period is 50 hours starting from the date of delivery to the first user.
- For Draglines, Electric Rope Shovels, Hard Rock Movers, Hard Rock Feeders; the warranty period is not to exceed 24 months from shipment of the last major component from the Caterpillar place of manufacture.

Caterpillar Responsibilities

If a defect in material or workmanship is found during the warranty period, Caterpillar will, during normal working hours and at a place of business of a Cat dealer or other source approved by Caterpillar:

- Provide (at Caterpillar's choice) new, remanufactured, or Caterpillar approved repaired parts or assembled components needed to correct the defect.

Note: New, remanufactured, or Caterpillar approved replacement parts provided under the terms of this warranty are warranted for the remainder of the warranty period applicable to the product in which installed as if such parts were original components of that product. Items replaced under this warranty become the property of Caterpillar.

- Replace lubricating oil, filters, antifreeze, and other service items made unusable by the defect.
- Provide reasonable and customary labor needed to correct the defect.

User Responsibilities

The user is responsible for:

- Providing proof of delivery date to the first user.

- Labor costs, except as stated under "Caterpillar Responsibilities."
- Transportation costs, except as stated under "Caterpillar Responsibilities."
- Premium or overtime labor costs.
- Parts shipping charges in excess of those that are considered usual and customary.
- Local taxes, if applicable.
- Costs to investigate complaints, unless the problem is caused by a defect in Caterpillar material or workmanship.
- Giving timely notice of a warrantable failure and promptly making the product available for repair.
- Performance of the required maintenance (including use of proper fuel, oil, lubricants, and coolant) and items replaced due to normal wear and tear.
- Allowing Caterpillar access to all electronically stored data.

Limitations

Caterpillar is not responsible for:

- Failures resulting from any use or installation that Caterpillar judges improper.
- Failures resulting from attachments, accessory items, and parts not sold or approved by Caterpillar.
- Failures resulting from abuse, neglect, and/or improper storage or repair.
- Failures resulting from user's delay in making the product available after being notified of a potential product problem.
- Failures resulting from unauthorized repair or adjustments, and unauthorized fuel setting changes.

(Continued on the reverse side....)

This warranty covers every major component of the products. Claims under this warranty should be submitted to a place of business of a Cat dealer or other source approved by Caterpillar. For further information concerning either the location to submit claims or Caterpillar as the issuer of this warranty, write Caterpillar Inc., 100 N. E. Adams St., Peoria, IL USA 61629.

Caterpillar's obligations under this Limited Warranty are subject to, and shall not apply in contravention of, the laws, rules, regulations, directives, ordinances, orders, or statutes of the United States, or of any other applicable jurisdiction, without recourse or liability with respect to Caterpillar.

A) For products operating outside of Australia, Fiji, Nauru, New Caledonia, New Zealand, Papua New Guinea, the Solomon Islands, and Tahiti, the following is applicable:

NEITHER THE FOREGOING EXPRESS WARRANTY NOR ANY OTHER WARRANTY BY CATERPILLAR, EXPRESS OR IMPLIED, IS APPLICABLE TO ANY ITEM CATERPILLAR SELLS THAT IS WARRANTED DIRECTLY TO THE USER BY ITS MANUFACTURER.

THIS WARRANTY IS EXPRESSLY IN LIEU OF ANY OTHER WARRANTIES, EXPRESS OR IMPLIED, INCLUDING ANY WARRANTY OF MERCHANTABILITY OR FITNESS FOR A PARTICULAR PURPOSE, EXCEPT CATERPILLAR EMISSION-RELATED COMPONENTS WARRANTY FOR NEW ENGINES, WHERE APPLICABLE. REMEDIES UNDER THIS WARRANTY ARE LIMITED TO THE PROVISION OF MATERIAL AND SERVICES, AS SPECIFIED HEREIN.

CATERPILLAR IS NOT RESPONSIBLE FOR INCIDENTAL OR CONSEQUENTIAL DAMAGES.

CATERPILLAR EXCLUDES ALL LIABILITY FOR OR ARISING FROM ANY NEGLIGENCE ON ITS PART OR ON THE PART OF ANY OF ITS EMPLOYEES, AGENTS, OR REPRESENTATIVES IN RESPECT OF THE MANUFACTURE OR SUPPLY OF GOODS OR THE PROVISION OF SERVICES RELATING TO THE GOODS.

IF OTHERWISE APPLICABLE, THE VIENNA CONVENTION ON CONTRACTS FOR THE INTERNATIONAL SALE OF GOODS IS EXCLUDED IN ITS ENTIRETY.

B) For products operating in Australia, Fiji, Nauru, New Caledonia, New Zealand, Papua New Guinea, the Solomon Islands, and Tahiti, the following is applicable:

THIS WARRANTY IS IN ADDITION TO WARRANTIES AND CONDITIONS IMPLIED BY STATUTE AND OTHER STATUTORY RIGHTS AND OBLIGATIONS THAT BY ANY APPLICABLE LAW CANNOT BE EXCLUDED, RESTRICTED OR MODIFIED ("MANDATORY RIGHTS"). ALL OTHER WARRANTIES OR CONDITIONS, EXPRESS OR IMPLIED (BY STATUTE OR OTHERWISE), ARE EXCLUDED, WITHOUT LIMITING THE FOREGOING PROVISIONS OF THIS PARAGRAPH, WHERE A PRODUCT IS SUPPLIED FOR BUSINESS PURPOSES, THE CONSUMER GUARANTEES UNDER THE CONSUMER GUARANTEES ACT 1993 (NZ) WILL NOT APPLY.

NEITHER THIS WARRANTY NOR ANY OTHER CONDITION OR WARRANTY BY CATERPILLAR, EXPRESS OR IMPLIED (SUBJECT ONLY TO THE MANDATORY RIGHTS), IS APPLICABLE TO ANY ITEM CATERPILLAR SELLS THAT IS WARRANTED DIRECTLY TO THE USER BY ITS MANUFACTURER.

IF THE MANDATORY RIGHTS MAKE CATERPILLAR LIABLE IN CONNECTION WITH SERVICES OR GOODS, THEN TO THE EXTENT PERMITTED UNDER THE MANDATORY RIGHTS, THAT LIABILITY SHALL BE LIMITED AT CATERPILLAR'S OPTION TO (a) IN THE CASE OF SERVICES, THE SUPPLY OF THE SERVICES AGAIN OR THE PAYMENT OF THE COST OF HAVING THE SERVICES SUPPLIED AGAIN AND (b) IN THE CASE OF GOODS, THE REPAIR OR REPLACEMENT OF THE GOODS, THE SUPPLY OF EQUIVALENT GOODS, THE PAYMENT OF THE COST OF SUCH REPAIR OR REPLACEMENT OR THE ACQUISITION OF EQUIVALENT GOODS.

CATERPILLAR EXCLUDES ALL LIABILITY FOR OR ARISING FROM ANY NEGLIGENCE ON ITS PART OR ON THE PART OF ANY OF ITS EMPLOYEES, AGENTS OR REPRESENTATIVES IN RESPECT OF THE MANUFACTURE OR SUPPLY OF GOODS OR THE PROVISION OF SERVICES RELATING TO THE GOODS.

CATERPILLAR IS NOT LIABLE FOR INCIDENTAL OR CONSEQUENTIAL DAMAGES UNLESS IMPOSED UNDER MANDATORY RIGHTS. IF OTHERWISE APPLICABLE, THE VIENNA CONVENTION (CONTRACTS FOR THE INTERNATIONAL SALE OF GOODS) IS EXCLUDED IN ITS ENTIRETY.

C) For products supplied in Australia:

IF THE PRODUCTS TO WHICH THIS WARRANTY APPLIES ARE:

- I. PRODUCTS OF A KIND ORDINARILY ACQUIRED FOR PERSONAL, DOMESTIC OR HOUSEHOLD USE OR CONSUMPTION; OR
- II. PRODUCTS THAT COST AUD 40,000 OR LESS,

WHERE THOSE PRODUCTS WERE NOT ACQUIRED FOR THE PURPOSE OF RE-SUPPLY OR FOR THE PURPOSE OF USING THEM UP OR TRANSFORMING THEM IN THE COURSE OF PRODUCTION OR MANUFACTURE OR IN THE COURSE OF REPAIRING OTHER GOODS OR FIXTURES, THEN THIS SECTION C APPLIES.

THE FOLLOWING MANDATORY TEXT IS INCLUDED PURSUANT TO THE AUSTRALIAN CONSUMER LAW AND INCLUDES REFERENCES TO RIGHTS THE USER MAY HAVE AGAINST THE DIRECT SUPPLIER OF THE PRODUCTS: OUR GOODS COME WITH GUARANTEES THAT CANNOT BE EXCLUDED UNDER THE AUSTRALIAN CONSUMER LAW. YOU ARE ENTITLED TO A REPLACEMENT OR REFUND FOR A MAJOR FAILURE AND COMPENSATION FOR ANY OTHER REASONABLY FORESEEABLE LOSS OR DAMAGE. YOU ARE ALSO ENTITLED TO HAVE THE GOODS REPAIRED OR REPLACED IF THE GOODS FAIL TO BE OF ACCEPTABLE QUALITY AND THE FAILURE DOES NOT AMOUNT TO A MAJOR FAILURE. THE INCLUSION OF THIS TEXT DOES NOT CONSTITUTE ANY REPRESENTATION OR ACCEPTANCE BY CATERPILLAR OF LIABILITY TO THE USER OR ANY OTHER PERSON IN ADDITION TO THAT WHICH CATERPILLAR MAY HAVE UNDER THE AUSTRALIAN CONSUMER LAW.

TO THE EXTENT THE PRODUCTS FALL WITHIN THIS SECTION C BUT ARE NOT OF A KIND ORDINARILY ACQUIRED FOR PERSONAL, DOMESTIC OR HOUSEHOLD USE OR CONSUMPTION, CATERPILLAR LIMITS ITS LIABILITY TO THE EXTENT IT IS PERMITTED TO DO SO UNDER THE AUSTRALIAN CONSUMER LAW TO, AT ITS OPTION, THE REPAIR OR REPLACEMENT OF THE PRODUCTS, THE SUPPLY OF EQUIVALENT PRODUCTS, OR THE PAYMENT OF THE COST OF SUCH REPAIR OR REPLACEMENT OR THE ACQUISITION OF EQUIVALENT PRODUCTS.

THE WARRANTY SET OUT IN THIS DOCUMENT IS GIVEN BY CATERPILLAR INC. OR ANY OF ITS SUBSIDIARIES, 100 N. E. ADAMS ST, PEORIA, IL USA 61629, TELEPHONE 1 309 675 1000. THE USER IS RESPONSIBLE FOR ALL COSTS ASSOCIATED WITH MAKING A CLAIM UNDER THE WARRANTY SET OUT IN THIS DOCUMENT, EXCEPT AS EXPRESSLY STATED OTHERWISE IN THIS DOCUMENT, AND THE USER IS REFERRED TO THE BALANCE OF THE DOCUMENT TERMS CONCERNING CLAIM PROCEDURES, CATERPILLAR RESPONSIBILITIES AND USER RESPONSIBILITIES.

TO THE EXTENT PERMISSIBLE BY LAW, THE TERMS SET OUT IN THE REMAINDER OF THIS WARRANTY DOCUMENT (INCLUDING SECTION B) CONTINUE TO APPLY TO PRODUCTS TO WHICH THIS SECTION C APPLIES.

©2014 Caterpillar All Rights Reserved. CAT, CATERPILLAR, their respective logos, "Caterpillar Yellow," the "Power Edge" trade dress as well as corporate and product identity used herein, are trademarks of Caterpillar and may not be used without permission.



Employment Eligibility Verification

Welcome Terence Barton

User ID TMOP6402

Last Login 09:22 AM - 01/06/2012 Log Out



Click any icon for help

- Home
- My Cases
- New Case
- View Cases
- Search Cases
- My Profile
- Edit Profile
- Change Password
- Change Security Questions
- My Company
- Edit Company Profile
- Add New User
- View Existing Users
- Close Company Account
- My Reports
- View Reports
- My Resources
- View Essential Resources
- Take Tutorial
- View User Manual
- Contact Us

Company Information

Company Name: Thompson Tractor Co., Inc.

Company ID Number: 47130

Doing Business As (DBA) Name:

DUNS Number:

[View / Edit](#)

Physical Location:

Address 1: 2401 Pinson Highway

Address 2:

City: Birmingham

State: AL

Zip Code: 35217

County: JEFFERSON

Mailing Address:

Address 1: P O. Box 10367

Address 2:

City: Birmingham

State: AL

Zip Code: 35202-0367

Additional Information:

Employer Identification Number: 630377478

Total Number of Employees: 1,000 to 2,499

Parent Organization:

Administrator:

Organization Designation:

Employer Category:

NAICS Code: 423 - MERCHANT WHOLESALERS, DURABLE GOODS

[View / Edit](#)

Total Hiring Sites: 40

[View / Edit](#)

Total Points of Contact: 3

[View / Edit](#)

[View PDF](#)

Request for Taxpayer Identification Number and Certification

Give form to the requester. Do not send to the IRS.

Print or type See Specific Instructions on page 2.	Name (as shown on your income tax return) Thompson Tractor Co., Inc. DBA Thompson Power Systems, Thompson Lift Truck Co.	
	Business name, if different from above and The Cat Rent Store	
	Check appropriate box: <input type="checkbox"/> Individual/sole proprietor <input checked="" type="checkbox"/> Corporation <input type="checkbox"/> Partnership <input type="checkbox"/> Limited liability company. Enter the tax classification (D=disregarded entity, C=corporation, P=partnership) ▶ <input checked="" type="checkbox"/> Exempt payee <input type="checkbox"/> Other (see instructions) ▶	
	Address (number, street, and apt. or suite no.) P O Box 10367 2401 Pinson Hwy. Tarrant, AL 35217	
	City, state, and ZIP code Birmingham, AL 35202-0367	
	List account number(s) here (optional) Lockbox Remit To: P O Box 934065, Atlanta, GA 31193-4005	

Part I Taxpayer Identification Number (TIN)	
Enter your TIN in the appropriate box. The TIN provided must match the name given on Line 1 to avoid backup withholding. For individuals, this is your social security number (SSN). However, for a resident alien, sole proprietor, or disregarded entity, see the Part I Instructions on page 3. For other entities, it is your employer identification number (EIN). If you do not have a number, see <i>How to get a TIN</i> on page 3.	Social security number : : :
	or
Note. If the account is in more than one name, see the chart on page 4 for guidelines on whose number to enter.	Employer identification number 63 : 0377478

Part II Certification	
Under penalties of perjury, I certify that:	
1. The number shown on this form is my correct taxpayer identification number (or I am waiting for a number to be issued to me), and	
2. I am not subject to backup withholding because: (a) I am exempt from backup withholding, or (b) I have not been notified by the Internal Revenue Service (IRS) that I am subject to backup withholding as a result of a failure to report all interest or dividends, or (c) the IRS has notified me that I am no longer subject to backup withholding, and	
3. I am a U.S. citizen or other U.S. person (defined below).	
Certification Instructions. You must cross out item 2 above if you have been notified by the IRS that you are currently subject to backup withholding because you have failed to report all interest and dividends on your tax return. For real estate transactions, item 2 does not apply. For mortgage interest paid, acquisition or abandonment of secured property, cancellation of debt, contributions to an individual retirement arrangement (IRA), and generally, payments other than interest and dividends, you are not required to sign the Certification, but you must provide your correct TIN. See the Instructions on page 4.	

Sign Here	Signature of U.S. person ▶ <i>Linda L. Dumas, Controller</i>	Date ▶
------------------	--	--------

General Instructions
Section references are to the Internal Revenue Code unless otherwise noted.

Purpose of Form
A person who is required to file an information return with the IRS must obtain your correct taxpayer identification number (TIN) to report, for example, income paid to you, real estate transactions, mortgage interest you paid, acquisition or abandonment of secured property, cancellation of debt, or contributions you made to an IRA.

Use Form W-9 only if you are a U.S. person (including a resident alien), to provide your correct TIN to the person requesting it (the requester) and, when applicable, to:

1. Certify that the TIN you are giving is correct (or you are waiting for a number to be issued),
2. Certify that you are not subject to backup withholding, or
3. Claim exemption from backup withholding if you are a U.S. exempt payee. If applicable, you are also certifying that as a U.S. person, your allocable share of any partnership income from a U.S. trade or business is not subject to the withholding tax on foreign partners' share of effectively connected income.

Note. If a requester gives you a form other than Form W-9 to request your TIN, you must use the requester's form if it is substantially similar to this Form W-9.

Definition of a U.S. person. For federal tax purposes, you are considered a U.S. person if you are:

- An individual who is a U.S. citizen or U.S. resident alien,
- A partnership, corporation, company, or association created or organized in the United States or under the laws of the United States,
- An estate (other than a foreign estate), or
- A domestic trust (as defined in Regulations section 301.7701-7).

Special rules for partnerships. Partnerships that conduct a trade or business in the United States are generally required to pay a withholding tax on any foreign partners' share of income from such business. Further, in certain cases where a Form W-9 has not been received, a partnership is required to presume that a partner is a foreign person, and pay the withholding tax. Therefore, if you are a U.S. person that is a partner in a partnership conducting a trade or business in the United States, provide Form W-9 to the partnership to establish your U.S. status and avoid withholding on your share of partnership income.

The person who gives Form W-9 to the partnership for purposes of establishing its U.S. status and avoiding withholding on its allocable share of net income from the partnership conducting a trade or business in the United States is in the following cases:

- The U.S. owner of a disregarded entity and not the entity.

Company ID Number: 47130

the Employer issues a tentative nonconfirmation based upon a photo non-match. The Employer will determine whether the employee contests the tentative nonconfirmation as soon as possible after the Employer receives it.

4. If the employee contests a tentative nonconfirmation issued by DHS, the Employer will provide the employee with a referral letter and instruct the employee to contact the Department through its toll-free hotline within 8 Federal Government work days.

5. If the employee contests a tentative nonconfirmation based upon a photo non-match, the Employer will provide the employee with a referral letter to DHS. DHS will electronically transmit the result of the referral to the Employer within 10 Federal Government work days of the referral unless it determines that more than 10 days is necessary.

6. The Employer agrees that if an employee contests a tentative nonconfirmation based upon a photo non-match, the Employer will send a copy of the employee's Form I-551 or Form I-766 to DHS for review by:

- Scanning and uploading the document, or
- Sending a photocopy of the document by an express mail account (furnished and paid for by DHS).

7. The Employer understands that if it cannot determine whether there is a photo match/non-match, the Employer is required to forward the employee's documentation to DHS by scanning and uploading, or by sending the document as described in the preceding paragraph, and resolving the case as specified by the Immigration Services Verifier at DHS who will determine the photo match or non-match.

ARTICLE IV

SERVICE PROVISIONS

The SSA and DHS will not charge the Employer for verification services performed under this MOU. The Employer is responsible for providing equipment needed to make inquiries. To access the E-Verify System, an Employer will need a personal computer with Internet access.

ARTICLE V

PARTIES

This MOU is effective upon the signature of all parties, and shall continue in effect for as long as the SSA and DHS conduct the E-Verify program unless modified in writing by the mutual consent of all parties, or terminated by any party upon 30 days prior written notice to the others. Any and all system enhancements to the E-Verify program by DHS or SSA, including but not limited to the E-Verify checking against additional data sources and instituting new verification procedures, will be covered under this MOU and will not cause the need for a supplemental MOU that outlines these changes. DHS agrees to train employers on all changes made to E-Verify through the use of mandatory refresher tutorials and updates to the E-Verify manual. Even

Company ID Number: 47130

without changes to E-Verify, the Department reserves the right to require employers to take mandatory refresher tutorials.

Termination by any party shall terminate the MOU as to all parties. The SSA or DHS may terminate this MOU without prior notice if deemed necessary because of the requirements of law or policy, or upon a determination by SSA or DHS that there has been a breach of system integrity or security by the Employer, or a failure on the part of the Employer to comply with established procedures or legal requirements. Some or all SSA and DHS responsibilities under this MOU may be performed by contractor(s), and SSA and DHS may adjust verification responsibilities between each other as they may determine.

Nothing in this MOU is intended, or should be construed, to create any right or benefit, substantive or procedural, enforceable at law by any third party against the United States, its agencies, officers, or employees, or against the Employer, its agents, officers, or employees.

Each party shall be solely responsible for defending any claim or action against it arising out of or related to E-Verify or this MOU, whether civil or criminal, and for any liability wherefrom, including (but not limited to) any dispute between the Employer and any other person or entity regarding the applicability of Section 403(d) of IIRIRA to any action taken or allegedly taken by the Employer.

The employer understands that the fact of its participation in E-Verify is not confidential information and may be disclosed as authorized or required by law and DHS or SSA policy, including but not limited to, Congressional oversight, E-Verify publicity and media inquiries, and responses to inquiries under the Freedom of Information Act (FOIA).

The foregoing constitutes the full agreement on this subject between the SSA, DHS, and the Employer.

The individuals whose signatures appear below represent that they are authorized to enter into this MOU on behalf of the Employer and DHS respectively.

To be accepted as a participant in E-Verify, you should only sign the Employer's Section of the signature page. If you have any questions, contact E-Verify Operations at 888-464-4218.

Employer Thompson Tractor Co., Inc.

Frank M Wright

Name (Please type or print)

Title

Electronically Signed

07/11/2007

Signature

Date

Department of Homeland Security – Verification Division

Company ID Number: 47130

**INFORMATION REQUIRED
FOR THE E-VERIFY PROGRAM**

Information relating to your Company:

Company Name: Thompson Tractor Co., Inc.

Company Facility Address: 2401 Pinson Highway
Birmingham, AL 35217

Company Alternate Address: P.O. Box 10367
Birmingham, AL 35202-0367

County or Parish: JEFFERSON

Employer Identification Number: 630377478

North American Industry
Classification Systems Code: 423

Parent Company: _____

Number of Employees: 1,000 to
2,499 Number of Sites Verified for: 5

Are you verifying for more than 1 site? If yes, please provide the number of sites verified for in each State.

- GEORGIA 5 site(s)

Information relating to the Program Administrator(s) for your Company on policy questions or operational problems:

Name: Kimberly A Stark
Telephone Number: (205) 849 - 4279 Fax Number: (205) 849 - 4565
E-mail Address: kimberlystark@thompsontractor.com

Name: Frank M Wright
Telephone Number: (205) 849 - 4267 Fax Number: (205) 849 - 4854
E-mail Address: frankwright@thompsontractor.com

Company ID Number: 47130

USCIS Verification Division

Name (Please type or print) _____

Title _____

Electronically Signed

07/11/2007

Signature _____

Date _____